**Medical devices — Connectors
for reservoir delivery systems for
healthcare applications —**

**Part 7:
Connectors for intravascular infusion**

*Dispositifs médicaux — Connecteurs pour systèmes de livraison de
réservoir pour des applications de soins de santé —*

Partie 7: Connecteurs pour perfusion intravasculaire

Document Preview

ISO 18250-7:2018

<https://standards.iteh.ai/catalog/standards/iso/16676ca9-fc4c-4294-837a-e77dfa4602df/iso-18250-7-2018>



iTeh Standards
(<https://standards.itih.ai>)
Document Preview

[ISO 18250-7:2018](https://standards.itih.ai/catalog/standards/iso/16676ca9-fc4c-4294-837a-e77dfa4602df/iso-18250-7-2018)

<https://standards.itih.ai/catalog/standards/iso/16676ca9-fc4c-4294-837a-e77dfa4602df/iso-18250-7-2018>



COPYRIGHT PROTECTED DOCUMENT

© ISO 2018

All rights reserved. Unless otherwise specified, or required in the context of its implementation, no part of this publication may be reproduced or utilized otherwise in any form or by any means, electronic or mechanical, including photocopying, or posting on the internet or an intranet, without prior written permission. Permission can be requested from either ISO at the address below or ISO's member body in the country of the requester.

ISO copyright office
CP 401 • Ch. de Blandonnet 8
CH-1214 Vernier, Geneva
Phone: +41 22 749 01 11
Fax: +41 22 749 09 47
Email: copyright@iso.org
Website: www.iso.org

Published in Switzerland

Contents

	Page
Foreword	iv
Introduction	vi
1 *Scope	1
2 Normative references	1
3 Terms and definitions	2
4 General requirements	2
4.1 Non-interconnectability through conformance to this document	2
4.2 * Intravascular RESERVOIR CONNECTOR types	2
5 Material requirements	3
5.1 CONNECTOR Type 1: spikes and administration ports	3
5.2 CONNECTOR Type 2: LUERS	3
6 Dimensional requirements	3
6.1 CONNECTOR Type 1: Spikes and Administration Ports	3
6.2 CONNECTOR Type 2: LUERS	3
7 Performance requirements	3
7.1 * CONNECTOR Type 1: Spikes and Administration Ports	3
7.2 CONNECTOR Type 2: LUERS	3
Annex A (informative) Rationale and guidance	4
Annex B (normative) Design of CONNECTORS*	13
Annex C (informative) Assessment of RESERVOIR CONNECTORS and their attributes with CONNECTIONS to medical devices within this intravascular APPLICATION	15
Annex D (informative) Summary of usability and requirements for CONNECTORS for intravascular RESERVOIRS	16
Annex E (informative) Summary of RESERVOIR CONNECTOR design requirements for INTRAVASCULAR INFUSION	19
Annex F (informative) Summary of engineering analysis and residual MISCONNECTIONS for CONNECTORS for intravascular RESERVOIRS	24
Annex G (informative) Alternative spikes	30
Bibliography	34

Foreword

ISO (the International Organization for Standardization) is a worldwide federation of national standards bodies (ISO member bodies). The work of preparing international standards is normally carried out through ISO technical committees. Each member body interested in a subject for which a technical committee has been established has the right to be represented on that committee. International organizations, governmental and non-governmental, in liaison with ISO, also take part in the work. ISO collaborates closely with the International Electrotechnical Commission (IEC) on all matters of electrotechnical standardization.

The procedures used to develop this document and those intended for its further maintenance are described in the ISO/IEC Directives, Part 1. In particular the different approval criteria needed for the different types of ISO documents should be noted. This document was drafted in accordance with the editorial rules of the ISO/IEC Directives, Part 2. www.iso.org/directives

Attention is drawn to the possibility that some of the elements of this document may be the subject of patent rights. ISO shall not be held responsible for identifying any or all such patent rights. Details of any patent rights identified during the development of the document will be in the Introduction and/or on the ISO list of patent declarations received. www.iso.org/patents

Any trade name used in this document is information given for the convenience of users and does not constitute an endorsement.

For an explanation on the voluntary nature of standards, the meaning of ISO specific terms and expressions related to conformity assessment, as well as information about ISO's adherence to the WTO principles in the Technical Barriers to Trade (TBT) see the following URL: [Foreword - Supplementary information](https://standards.iteh.ai/Foreword-Supplementary-information)

This document was prepared by Technical Committee ISO/TC 210, *Quality management and corresponding general aspects for medical devices*.

A list of all the parts in the ISO 18250 series can be found on the ISO website.

In this document, the following print types are used:

- Requirements and definitions: roman type.
- Informative material appearing outside of tables, such as notes, examples and references: in smaller type. Normative text of tables is also in smaller type.
- TERMS DEFINED IN STANDARD OR AS NOTED: SMALL CAPITALS.
- *Compliance requirements: italic type.*

In this document, the conjunctive “or” is used as an “inclusive or” so a statement is true if any combination of the conditions is true.

The verbal forms used in this document conform to usage described in Annex H of the ISO/IEC Directives, Part 2. For the purposes of this document, the auxiliary verb:

- “shall” means that compliance with a requirement or a test is mandatory for compliance with this document,
- “should” means that compliance with a requirement or a test is recommended but is not mandatory for compliance with this document, and
- “may” is used to describe a permissible way to achieve compliance with a requirement or test.

An asterisk (*) as the first character of a title or at the beginning of a paragraph or table title indicates that there is guidance or rationale related to that item in [Annex A](#).

Any feedback or questions on this document should be directed to the user's national standards body. A complete listing of these bodies can be found at www.iso.org/members.html.

iTeh Standards
(<https://standards.iteh.ai>)
Document Preview

ISO 18250-7:2018

<https://standards.iteh.ai/catalog/standards/iso/16676ca9-fc4c-4294-837a-e77dfa4602df/iso-18250-7-2018>

Introduction

During the development of the standard for enteral small-bore CONNECTORS (ISO 80369-3), it became clear that the risk of MISCONNECTIONS was not limited to the PATIENT access CONNECTORS and that the whole enteral system needed to be considered. The possible MISCONNECTION between enteral feed RESERVOIR access CONNECTORS and the spikes typically used on intravenous administration sets was also reviewed. However, as feed RESERVOIR CONNECTORS are not exactly within the definition of small-bore CONNECTORS, it was decided to develop a separate standard (ISO 18250-3) for these CONNECTORS, taking into account the risks of MISCONNECTIONS with other devices such as intravenous (IV) bags.

During the development of ISO 18250-3, it became apparent that the ubiquitous intravenous spike was specified in various ISO medical device standards but that the geometry and materials requirements for the female port on the intravenous RESERVOIR were not defined. However, the performance of this female port was defined in various ISO standards.

This document, therefore, specifies the design, dimensions and materials for the female port. It makes reference to existing performance standards. It also includes tests to validate that the spike and the female port do not interconnect with the other RESERVOIR CONNECTORS of the ISO 18250 series.

This document also includes analysis sufficient to include traditional LUER CONNECTORS of ISO 80369-7 as permissible RESERVOIR CONNECTORS for intravascular APPLICATIONS.

This document is not a device standard as it specifies only the requirements of the interfaces for CONNECTORS used in intravascular RESERVOIRS and INTRAVASCULAR INFUSION SETS.

iteh Standards
(<https://standards.iteh.ai>)
Document Preview

[ISO 18250-7:2018](https://standards.iteh.ai/catalog/standards/iso/16676ca9-fc4c-4294-837a-e77dfa4602df/iso-18250-7-2018)

<https://standards.iteh.ai/catalog/standards/iso/16676ca9-fc4c-4294-837a-e77dfa4602df/iso-18250-7-2018>

Medical devices — Connectors for reservoir delivery systems for healthcare applications —

Part 7: Connectors for intravascular infusion

1 *Scope

This document specifies the interface dimensions and requirements for the design and functional performance of CONNECTORS intended to be used to connect INTRAVASCULAR INFUSION SETS to INTRAVASCULAR INFUSION RESERVOIRS.

This document does not specify the dimensions and requirements for the medical devices or ACCESSORIES that use these CONNECTORS. Such requirements are given in particular international standards for specific medical devices or ACCESSORIES.

EXAMPLES Medical devices which may use intravascular RESERVOIR CONNECTORS are the following:

- Administration ports on IV fluid RESERVOIRS and the mating spikes of IV administration/INTRAVASCULAR INFUSION SETS/lines, e.g., IV bags/containers and the spike inlet ends of IV sets;
- Devices intended to be connected in series between the administration port of IV fluid RESERVOIRS and the mating spikes of IV administration/giving lines;
- Syringes and syringe IV sets utilizing LUER CONNECTORS.

The following CONNECTORS are excluded from the scope of this document:

- Stoppers for bottles as specified in ISO 8536-2;
- Compounding/admixture ports on IV RESERVOIRS and intended mating devices.

EXAMPLES Rubber stoppers used for injection into the RESERVOIR and the mating pharmacy admixture devices (syringes, needles, reconstitution devices, and other ancillary equipment used to access the compounding or admixture ports).

- The fill ports of non-powered (i.e. elastomeric) pumps.

NOTE 1 Details of alternative spikes that are in common use are located in [Annex G](#) for informational purposes.

NOTE 2 Manufacturers are encouraged to incorporate the CONNECTORS specified in this document into INTRAVASCULAR INFUSION medical devices or ACCESSORIES, even if not currently required by the particular medical device standards. It is expected that when the particular medical device standards are revised, requirements for RESERVOIR CONNECTORS, as specified in ISO 18250, will be included.

2 Normative references

The following documents are referred to in the text in such a way that some or all of their content constitutes requirements of this document. For dated references, only the edition cited applies. For undated references, the latest edition of the referenced document (including any amendments) applies.

ISO 1135-4, *Transfusion equipment for medical use — Part 4: Transfusion sets for single use, gravity feed*

ISO 3826 (all parts), *Plastics collapsible containers for human blood and blood components*

ISO 18250-7:2018(E)

ISO 8536-4, *Infusion equipment for medical use — Part 4: Infusion sets for single use, gravity feed*¹⁾

ISO 15747, *Plastic containers for intravenous injections*

ISO 15759, *Medical infusion equipment — Plastics caps with inserted elastomeric liner for containers manufactured by the blow-fill-seal (BFS) process*

ISO 18250-1, *Medical devices — Connectors for reservoir delivery systems for healthcare applications — Part 1: General requirements and common test methods*

ISO 80369-7, *Small-bore connectors for liquids and gases in healthcare applications — Part 7: Connectors for intravascular or hypodermic applications*

3 Terms and definitions

For the purposes of this document, the terms and definitions given in ISO 18250-1 and the following apply.

ISO and IEC maintain terminological databases for use in standardization at the following addresses:

— ISO Online browsing platform: available at <https://www.iso.org/obp>

— IEC Electropedia: available at <http://www.electropedia.org/>

3.1

INTRAVASCULAR INFUSION SET

medical device for transferring liquids from an intravascular RESERVOIR to an intravascular catheter

3.2

INTRAVASCULAR INFUSION

administration of parenteral injection product into a blood vessel, including transfusion of blood products

3.3

LUER CONNECTOR

small-bore CONNECTOR that contains a conical mating surface with a 6 % (LUER) taper intended for use in intravascular or hypodermic APPLICATIONS of medical devices and related ACCESSORIES

[SOURCE: ISO 80369-7:2016, definition 3.1]

4 General requirements

4.1 Non-interconnectability through conformance to this document

Conformance to [Clause 5](#) (materials), [Clause 6](#) (dimensions), and [Clause 7](#) (physical performance) of this document is sufficient to demonstrate conformance to ISO 18250-1 (i.e. non-interconnectability with clinical APPLICATIONS other than intravascular).

NOTE 1 A summary of the evaluation and residual risks of the NON-INTERCONNECTABLE characteristics of the designs for this document is included in [F.2](#).

4.2 * Intravascular RESERVOIR CONNECTOR types

CONNECTOR Type 1: Spikes and Administration Ports. Spikes are intended to be on the INTRAVASCULAR INFUSION SET. Administration ports are intended to be on the RESERVOIR.

CONNECTOR Type 2: LUER CONNECTORS. Male LUER CONNECTORS are intended to be on the RESERVOIR (e.g. the syringe). Female LUER CONNECTORS are intended to be on the INTRAVASCULAR INFUSION SET.

1) Under preparation. Stage at the time of publication ISO/FDIS 8536-4:2018.

5 Material requirements

5.1 CONNECTOR Type 1: spikes and administration ports

Intravascular spikes shall be fabricated from materials with a tensile or flexural modulus (E) equal to or greater than 700 MPa.

Intravascular administration ports may be made from materials having any value for tensile or flexural modulus (E); it may vary within all ranges of flexible elastomers through semi-rigid and rigid polymers.

5.2 CONNECTOR Type 2: LUERS

LUERS used as intravascular RESERVOIR CONNECTORS shall conform to the materials requirements of ISO 80369-7.

Check compliance of [5.1](#) and [5.2](#) by inspection of the technical file.

6 Dimensional requirements

6.1 CONNECTOR Type 1: Spikes and Administration Ports

Intravascular spikes shall conform to the geometry for spikes defined in either ISO 8536-4 or ISO 1135-4 unless the use of these dimensions creates an unacceptable risk when attempting to make a CONNECTION to a RESERVOIR.

Intravascular administration ports shall meet the dimensional requirements defined in B.1.

6.2 CONNECTOR Type 2: LUERS

LUER CONNECTORS used as intravascular RESERVOIR CONNECTORS shall conform to the design/ dimensional requirements of ISO 80369-7.

Check compliance of [6.1](#) and [6.2](#) by inspection of the technical file.

7 Performance requirements

7.1 * CONNECTOR Type 1: Spikes and Administration Ports

Intravascular spikes shall conform to the performance requirements for spikes defined in either ISO 8536-4 or ISO 1135-4.

Intravascular administration ports shall meet the performance requirements of ISO 15747, ISO 15759, ISO 3826-1, or ISO 3826-4.

7.2 CONNECTOR Type 2: LUERS

LUER CONNECTORS used as intravascular RESERVOIR CONNECTORS shall conform to the performance requirements of ISO 80369-7.

Check compliance of [7.1](#) and [7.2](#) by inspection of the technical file.

Annex A (informative)

Rationale and guidance

A.1 General

This annex provides rationale for the important requirements of this document and is intended for those who are familiar with the subject of this document but who have not participated in its development. An understanding of the reasons for the main requirements is considered to be essential for its proper application. Furthermore, as clinical practice and technology change, it is believed that rationale for the present requirements will facilitate any revision of this document necessitated by those developments.

A.2 Rationale for particular clauses and subclauses

The clauses and subclauses in this annex have been numbered to correspond to the numbering of the clauses and subclauses of this document to which they refer. The numbering is, therefore, not consecutive.

Clause 1 Scope

The scope excludes stoppers for bottles as specified in ISO 8536-2 as by their nature the risk of unintentional CONNECTION cannot be mitigated by geometrical constraints without modifying the whole design of the stopper. These stoppers are considered less safe than the RESERVOIR CONNECTORS specified in this document and are therefore not recommended.

Subclause 4.2 Intravascular RESERVOIR CONNECTOR Types

CONNECTOR Type 2: A simple yet significant limitation of the ISO 80369-7 LUER is recognized by the working group to prevent its use in all intravascular RESERVOIR CONNECTOR APPLICATIONS: this is that the LUER does not permit the venting necessary to displace removed fluid in rigid and semi-rigid RESERVOIRS. The result of this is that the container will draw a vacuum that cannot be overcome by gravity or by the vacuum generated by typical IV pumps, thus stopping flow. Spikes that conform to ISO 8536-4 and ISO 1135-4 permit multiple interior lumens so that venting is possible.

Use of the male LUER on the RESERVOIR side is intended to prevent usability errors of transposing the orientation of the administration set.

The orientation of CONNECTORS promoted in 4.2 is consistent with the MISCONNECTION analysis of E.2. If manufacturers or device standards committees choose to use alternate orientations, then MISCONNECTION analysis should be revisited by the entity implementing the change.

Subclause 7.1 Performance requirements for CONNECTOR Type 1: spikes and administration ports

The working group debated multiple times how best to specify performance for the traditional spike and port CONNECTOR type 1. Initially the working group adopted / adapted applicable CONNECTION tests from various known device standards. The results of this work compiled four CONNECTION tests (penetration force, liquid leakage, flow rate, and adhesion strength tests), with specified reference fittings to permit consistent results.

Debate within the committee centered on what was the minimum criteria necessary for a CONNECTION – this criteria of course depends on the specific APPLICATION within INTRAVASCULAR INFUSION. With so many established device standards already providing various elements of CONNECTION testing, it was decided that to centralize these tests here in this document would force duplication of work and expense for some manufacturers.

It was decided therefore not to (re)define performance characteristics for CONNECTOR type 1 in this document, but to ensure that manufacturers are at least conforming to one of the existing recognized device standards. However, it is further recognized that these standards do not fully test the CONNECTION (for instance, in some cases not all tests are conducted, or in others the tests only are conducted with one half of the CONNECTION.)

[Table A.1](#) provides a summary of the strength/weakness of these existing device standards to fully define the performance of this CONNECTOR type 1.

Table A.1 — Limitations to CONNECTOR Type 1 performance requirements by applicable device standards

Standard	Penetrating force	Liquid leakage	Flow rate	Adhesion strength
ISO 8536-4	Not tested	♂ : 6.2	6.10	♂ : 6.3
ISO 1135-4	Not tested	♂ : 5.2	5.9	♂ : 5.3
ISO 15747	4.1.8	♀ : 4.1.2, 4.1.3	Not tested	4.1.9
ISO 15759	6.4	♀ : 5.1	Not tested	6.5, 6.6
ISO 3826-1	Not tested	♀ : 6.2.7	5.3	Not tested
ISO 3826-4	6.2.8	6.2.10	Not tested	6.2.9

Annex B.1 Design of CONNECTOR Type 1 administration port CONNECTORS

[Annex B](#) is a compilation and generalization of known, commercialized intravascular RESERVOIR CONNECTORS available during the time of development of this document. These are intended to mate with the spikes of ISO 8536-4 and ISO 1135-4. Dimensional surveys were sent to manufacturers participating in the development process. B.1 design can be interpreted in many ways, but in essence it shows how manufacturers have put the legacy performance requirements into practice. As a result, the table in [Annex B](#) indicates minimum and maximum values for various features; it does not provide a nominal nor espouse a set of target dimensions. As a result, the dimensions of commercialized product would not be distributed normally between the minimum and maximum, but might exist anywhere between them. The intention is to specify limits to main functional dimensions and therefore to freeze the allowed design space. It is hoped this will limit new designs which exceed those dimensions and thereby maintain validity of the CAD analysis.

In defining distance B, manufacturers should take into account deformation of the septum during piercing, particularly if the lateral extension of the septum is large, so that the septum may be deformed on a longer distance along the penetration axis, hence prevent establishing a fluid path to the lumen of the INTRAVASCULAR INFUSION SET.

Diameter E was added to [Figure B.1](#) to account for the exterior features of commercialized IV RESERVOIR ports. Exterior features of commercialized RESERVOIRS were surveyed, and the maximum diameter listed shows the extent of the commercialized devices. The possible external features of the CONNECTOR might exist anywhere within this theoretical cylinder, thus MISCONNECTION prevention features of other parts of the ISO 18250 series shall assure that they do not provide possible interference/mating with those exterior features. Dimension E extends to a singular CONNECTOR (i.e., administration port) only unless that administration port is somehow combined with in singular assembly that includes other features (such as a medication port).

The generic geometry of B.1 can be interpreted in a variety of ways. The following series of illustrations capture several commercial interpretations of these CONNECTORS that can be described using the geometry of B.1.

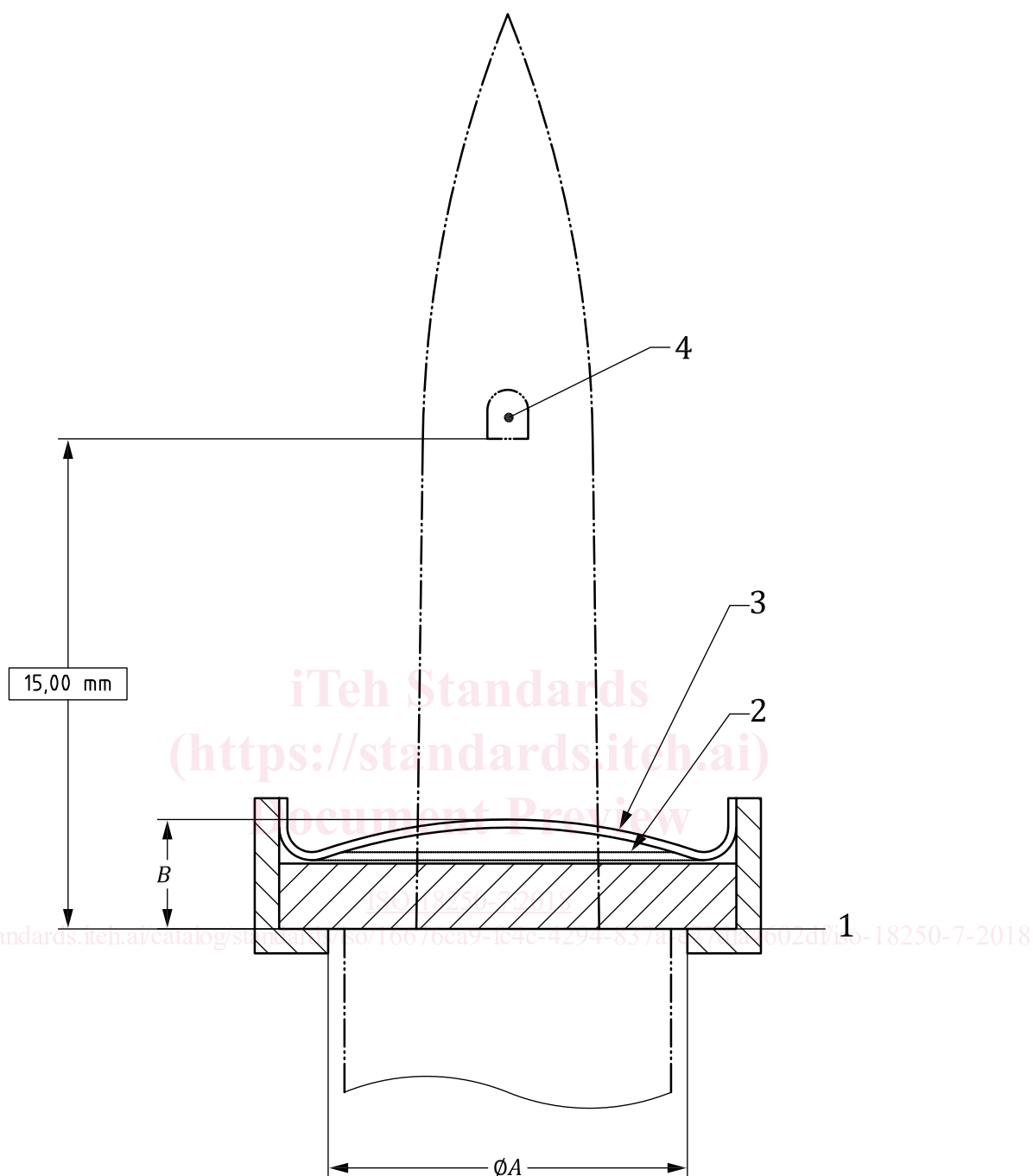

Key

- 1 level '0': Spike insertion stop – location where insertion travel of the spike will or could be stopped
- 2 free standing septum
- 3 in use septum
- 4 fluid channel opening
- ØA minimum internal diameter before the spike septum
- B depth from "Level 0" to last septum surface to be pierced to access solution

Figure A.1 — Single liner for administration port

This type of closure is typical for blow-fill-seal containers. A liner covered by a housing having a relatively large opening provides an exposed elastomeric surface with both medication and administration piercing areas. The liner is trapped between the housing and a support which may