



Designation: D5329 – 09

Standard Test Methods for Sealants and Fillers, Hot-Applied, for Joints and Cracks in Asphaltic and Portland Cement Concrete Pavements¹

This standard is issued under the fixed designation D5329; the number immediately following the designation indicates the year of original adoption or, in the case of revision, the year of last revision. A number in parentheses indicates the year of last reapproval. A superscript epsilon (ϵ) indicates an editorial change since the last revision or reapproval.

1. Scope

1.1 These test methods cover tests for hot-applied types of joint and crack sealants and fillers for portland cement concrete and asphaltic concrete pavements. There are numerous standard material specifications that use these test methods. Refer to the respective standard material specification of interest to determine which of the following test methods to use. For sample melting and concrete block preparation see their respective standard practices.

1.2 The test methods appear in the following sections:

	Section
Artificial Weathering	15
Asphalt Compatibility	14
Bond, Non-Immersed	9
Bond, Fuel-Immersed	11
Bond, Water-Immersed	10
Cone Penetration, Non-Immersed	6
Cone Penetration, Fuel-Immersed	7
Flexibility	18
Flow	8
Resilience	12
Resilience, Oven-Aged	13
Solubility	17
Tensile Adhesion	16

1.3 The values stated in SI units are to be regarded as the standard. The values given in parentheses are provided for information purposes only.

1.4 *This standard does not purport to address all of the safety concerns, if any, associated with its use. It is the responsibility of the user of this standard to establish appropriate safety and health practices and determine the applicability of regulatory limitations prior to use.*

2. Referenced Documents

2.1 *ASTM Standards:*²

[D5 Test Method for Penetration of Bituminous Materials](#)

¹ These test methods are under the jurisdiction of ASTM Committee D04 on Road and Paving Materials and are the direct responsibility of Subcommittee D04.33 on Formed In-Place Sealants for Joints and Cracks in Pavements.

Current edition approved June 1, 2009. Published July 2009. Originally approved in 1992. Last previous edition approved in 2007 as D5329 – 07. DOI: 10.1520/D5329-09.

² For referenced ASTM standards, visit the ASTM website, www.astm.org, or contact ASTM Customer Service at service@astm.org. For *Annual Book of ASTM Standards* volume information, refer to the standard's Document Summary page on the ASTM website.

- [D217 Test Methods for Cone Penetration of Lubricating Grease](#)
- [D471 Test Method for Rubber Property—Effect of Liquids](#)
- [D1074 Test Method for Compressive Strength of Bituminous Mixtures](#)
- [D1561 Practice for Preparation of Bituminous Mixture Test Specimens by Means of California Kneading Compactor](#)
- [D1985 Practice for Preparing Concrete Blocks for Testing Sealants, for Joints and Cracks](#)
- [D3381 Specification for Viscosity-Graded Asphalt Cement for Use in Pavement Construction](#)
- [D5167 Practice for Melting of Hot-Applied Joint and Crack Sealant and Filler for Evaluation](#)
- [D6690 Specification for Joint and Crack Sealants, Hot Applied, for Concrete and Asphalt Pavements](#)
- [E145 Specification for Gravity-Convection and Forced-Ventilation Ovens](#)
- [E171 Practice for Conditioning and Testing Flexible Barrier Packaging](#)
- [G151 Practice for Exposing Nonmetallic Materials in Accelerated Test Devices that Use Laboratory Light Sources](#)
- [G154 Practice for Operating Fluorescent Ultraviolet \(UV\) Lamp Apparatus for Exposure of Nonmetallic Materials](#)
- [G155 Practice for Operating Xenon Arc Light Apparatus for Exposure of Non-Metallic Materials](#)

3. Significance and Use

3.1 These test methods describe procedures for determining specification conformance for hot-applied, field-molded joint and crack sealants and fillers.

4. Sample Melting

4.1 See Practice [D5167](#).

5. Standard Conditions

5.1 The laboratory atmospheric conditions, hereinafter referred to as standard conditions, shall be in accordance with Specification [E171](#) ($23 \pm 2^\circ\text{C}$ ($73.4 \pm 3.6^\circ\text{F}$)).

6. Cone Penetration, Non-Immersed

6.1 *Scope*—This test method covers determination of cone penetration of bituminous joint and crack sealers and fillers.

6.2 *Significance and Use*—The cone penetration, non-immersed is a measure of consistency. Higher values indicate a softer consistency.

6.3 *Apparatus*—Conduct this test using the apparatus described in Test Method D5, except as specified herein. Use a penetration cone in place of the standard penetration needle. The cone shall conform to the requirements given in Test Methods D217, except that the interior construction may be modified as desired. The total moving weight of the cone and attachments shall be 150.0 ± 0.1 g.

6.4 *Specimen Preparation*—Pour a portion of the sample prepared in accordance with Practice D5167 into one 177 mL (6 oz) tin measuring approximately 70 mm in diameter and 45 mm in depth and fill flush with the rim of the tin. Allow the specimen to cure under standard conditions as specified in its respective material specification.

6.5 *Procedure*—Place the specimen in a water bath maintained at $25 \pm 0.1^\circ\text{C}$ ($77 \pm 0.2^\circ\text{F}$) for 2 h immediately before testing. Remove the specimen from the bath and dry the surface. Using the apparatus described in 6.3, make determinations at three locations on 120° radii, and halfway between the center and outside of the specimen. Take care to ensure the cone point is placed on a point in the specimen that is representative of the material itself and is free of dust, water, bubbles or other foreign material. Clean and dry the cone point after each determination.

6.6 *Report*—Average the three results and record the value as the penetration of the specimen in $\frac{1}{10}$ mm units.

6.7 *Precision and Bias:*

6.7.1 For Specification D6690 Type I materials, the following precision statement is based on an interlaboratory study of 12 laboratories that tested five different Specification D6690 Type I materials.

6.7.1.1 *Within Tin*—Single-Operator Precision (for penetration between 40 and 80): The single-operator deviation has been found to be 0.994. Therefore, results of two properly conducted tests by the same operator should not differ by more than three penetration units.

6.7.1.2 *Within and Between Laboratories*—Single-Operator Precision (penetrations 40 to 80): The single-operator standard deviation of a single test (test result is defined as the average of three penetrations) has been found to be 0.924. Therefore, the results of two properly conducted tests by the same operator on the same material should not differ by more than three penetration units.

6.7.1.3 *Multilaboratory Precision*—(penetration 40 to 80): The multilaboratory standard deviation of a single test (test result is defined as the average of three penetrations) has been found to be 3.249. Therefore, the results of two properly conducted tests in different laboratories should not differ by more than nine penetration units.

6.7.2 For Specification D6690 Type II materials, the following precision statement is based on an interlaboratory study of eleven laboratories that tested six different Specification D6690 Type II materials.

6.7.2.1 *Within Tin*—Single-Operator Precision (for penetration between 55 and 85): The single-operator deviation has

been found to be 0.974. Therefore, results of two properly conducted tests by the same operator should not differ by more than three penetration units.

6.7.2.2 *Within and Between Laboratories*—Single-Operator Precision (penetrations 50 to 70): The single-operator standard deviation of a single test (test result is defined as the average of three penetrations) has been found to be 1.0865. Therefore, the results of two properly conducted tests by the same operator on the same material should not differ by more than three penetration units.

6.7.2.3 *Single-Operator Precision*—(penetrations 71 to 85): The single-operator standard deviation of a single test (test result is defined as the average of three penetrations) has been found to be 2.237. Therefore, the results of two properly conducted tests by the same operator on the same material should not differ by more than six penetration units.

6.7.2.4 *Multilaboratory Precision*—(penetration 50 to 70): The multilaboratory standard deviation of a single test (test result is defined as the average of three penetrations) has been found to be 5.2609. Therefore, the results of two properly conducted tests in different laboratories should not differ by more than 15 penetration units.

6.7.2.5 *Multilaboratory Precision*—(penetration 71 to 85): The multilaboratory standard deviation of a single test (test result is defined as the average of three penetrations) has been found to be 16.8831. Therefore, the results of two properly conducted tests in different laboratories should not differ by more than 48 penetration units.

7. Cone Penetration, Fuel-Immersed

7.1 *Scope*—This test method covers the determination of cone penetration after immersion in reference fuel.

7.2 *Significance and Use*—The cone penetration is a measure of consistency of the material. Higher penetration values indicate a softer consistency. Large changes in penetration from the cone penetration, non-immersed value indicate a significant effect of the reference fuel on the sealant.

7.3 *Apparatus*—Same as described in 6.3.

7.4 *Specimen Preparation*—Pour a portion of the sample prepared in accordance with Practice D5167 into one 177 mL (6 oz) tin, then proceed as in 6.4.

7.5 *Specimen Preparation*—Immerse the specimen prepared as described in 6.4 for 24 h in approximately 500 mL (0.53 qt) to provide a minimum of 12 mm cover of clean test fuel conforming to the requirements of Reference Fuel B of Test Method D471, maintained in a water bath at a constant temperature of $40 \pm 1^\circ\text{C}$ ($120 \pm 2^\circ\text{F}$). Discard the test fuel after each specimen immersion. After the 24 h immersion, dry the specimen under a draft of an approximately 300 mm (12 in.) diameter electric fan at standard conditions for 1 h. The placement of the fan shall be such as to maintain air velocity of 0.75 to 2.50 m/s (150 to 500 ft/min) over the sample.

7.6 *Procedure*—Test as described in 6.5.

7.7 *Report*—Record as described in 6.6.

7.8 *Precision and Bias*—The precision and bias of this test method for measuring cone penetration are as specified in Section 6.

8. Flow

8.1 *Scope*—This test method measures the amount of flow of bituminous joint and crack sealants when held at a 75° angle at elevated temperatures.

8.2 *Significance and Use*—This test method is a means of measuring the ability of a sealant to resist flow from the joint or crack at high ambient temperatures.

8.3 Apparatus:

8.3.1 *Mold*—Construct a mold (see **Note 1**) 40 mm wide by 60 mm long by 3.2 mm deep (1.57 in. wide by 2.36 in. long by 0.125 in. deep) and place it on a bright tin panel. The tin plate must be free of dirt, oil, and so forth and be between 0.25 to 0.64 mm in thickness (0.010 and 0.025 in. in thickness).

NOTE 1—A release agent should be used to coat molds and spacers to prevent them from bonding to the sealants. Extreme care should be exercised to avoid contaminating the area where the joint sealant makes contact with the blocks. A non-toxic release agent is recommended for this purpose. Two examples that have been found suitable for this purpose are KY jelly (available at drug stores) and a release agent prepared by grinding a mixture of approximately 50 % talc, 35 % glycerine, and 15 % by weight, of a water-soluble medical lubricant into a smooth paste.

8.3.2 *Oven*—Forced draft type conforming to Specification **E145** and capable of controlling its temperature $\pm 1^\circ\text{C}$.

8.4 *Specimen Preparation*—Pour a portion of the sample prepared in accordance with Practice **D5167** for melting samples into the mold described in **8.3**. Fill the mold with an excess of material. Allow the test specimen to cool at standard conditions for at least ½ h, then trim the specimen flush with the face of the mold with a heated metal knife or spatula and remove the mold. Allow the specimen to cure under standard conditions as specified in its respective material specification.

8.5 *Procedure*—Mark reference lines on the panel at the bottom edge of the sealant. Then place the panel containing the sample in a forced-draft oven maintained for the time and at the temperature specified in its respective material specification. During the test, mount the panel so that the longitudinal axis of the specimen is at an angle of $75 \pm 1^\circ$ with the horizontal, and the transverse axis is horizontal. After the specified test period, remove the panel from the oven and measure the movement of the specimen below the reference lines in millimetres.

8.6 *Report*—Report the measurement obtained in **8.5** in millimetres.

8.7 Precision and Bias:

8.7.1 For Specification **D6690** Type I materials, the following precision statement is based on an interlaboratory study of 12 laboratories that tested five different Specification **D6690** Type I materials.

8.7.1.1 *Single-Operator Precision (flow 0 to 5)*—The single-operator standard deviation has been found to be 0.255. Therefore, the results of two properly conducted tests by the same operator should not differ by more than one flow unit.

8.7.1.2 *Single-Operator Precision (flow 5 to 10)*—The single-operator standard deviation has been found to be 1.024. Therefore, the results of two properly conducted tests by the same operator should not differ by more than three flow units.

8.7.1.3 *Multilaboratory Precision (flow 0 to 5)*—The multi-laboratory standard deviation has been found to be 4.256. Therefore, the results of two properly conducted tests in different laboratories should not differ by more than 12 flow units.

8.7.1.4 *Multilaboratory Precision (flow 5 to 10)*—The multi-laboratory standard deviation has been found to be 5.326. Therefore, the results of two properly conducted tests in different laboratories should not differ by more than 15 flow units.

8.7.2 For Specification **D6690** Type II materials, the following precision statement is based on an interlaboratory study of eleven laboratories that tested six different Specification **D6690** Type II materials.

8.7.2.1 *Single-Operator Precision (flow 0 to 1)*—The single-operator standard deviation has been found to be 0.2494. Therefore, the results of two properly conducted tests by the same operator should not differ by more than one flow unit.

8.7.2.2 *Single-Operator Precision (flow 1.1 to 4)*—The single-operator standard deviation has been found to be 0.7616. Therefore, the results of two properly conducted tests by the same operator should not differ by more than three flow units.

8.7.2.3 *Multilaboratory Precision (flow 0 to 1)*—The multi-laboratory standard deviation has been found to be 0.5644. Therefore, the results of two properly conducted tests in different laboratories should not differ by more than three flow units.

8.7.2.4 *Multilaboratory Precision (flow 1.1 to 4)*—The multi-laboratory standard deviation has been found to be 2.3508. Therefore, the results of two properly conducted tests in different laboratories should not differ by more than seven flow units.

9. Bond, Non-Immersed

9.1 *Scope*—This test method is used to evaluate the bond to concrete.

9.2 *Significance and Use*—Bond to concrete is necessary for a sealant to maintain proper field performance.

9.3 Apparatus:

9.3.1 *Extension Machine*—The extension machine used in the bond test shall be so designed that the specimen can be extended a minimum of 12.5 mm (0.5 in.) at a uniform rate of 3.1 ± 0.3 mm (0.125 ± 0.010 in.) per hour. It shall consist essentially of one or more screws rotated by an electric motor through suitable gear reductions. Self aligning plates or grips, one fixed and the other carried by the rotating screw or screws, shall be provided for holding the test specimen in position during the test.³

9.3.2 *Cold Chamber*—The cold chamber shall be capable of maintaining the required cold test temperature within $\pm 1^\circ\text{C}$.

9.4 Concrete-Block Preparation:

³ The sole source of supply of the apparatus known to the committee at this time is Applied Test Systems of Butler, PA. If you are aware of alternative suppliers, please provide this information to ASTM International Headquarters. Your comments will receive careful consideration at a meeting of the responsible technical committee,¹ which you may attend.

9.4.1 The concrete blocks shall be prepared in accordance with Practice D1985.

9.5 Specimen Preparation:

9.5.1 Prepare three test specimens (3 specimens \times 2 = 6 blocks) as follows: On removal from the storage container, again scrub the 50 by 75-mm (2 by 3-in.) saw-cut faces of the blocks under running water. When all blocks are scrubbed, lightly blot them with an oil-free, soft, absorbent cloth or paper to remove all free surface water and condition them according to their respective material specification.

9.5.2 Take these blocks and mold the test specimen between them as follows (see Fig. 1): Place four treated (see Note 1) brass or TFE-fluorocarbon spacer strips, approximately 6 mm ($\frac{1}{4}$ in.) thick, on a treated metal plate base to enclose an open space according to the width specified in the respective material specification by 50 mm (2 in.) long. Place the blocks on the spacer strips and space them the required width ± 0.1 mm (± 0.005 in.) apart by means of other treated brass or TFE-fluorocarbon spacer strips, of the required width placed at such distances from the ends that an opening is of the required width by 50.80 ± 0.13 mm by 50.80 ± 0.13 mm (required width by 2.000 ± 0.005 in. by 2.000 ± 0.005 in.) is formed between the blocks with a 6.4-mm ($\frac{1}{4}$ -in.) opening below the blocks.

9.5.3 Rubber bands, clamps, or similar suitable means may be used to hold the blocks in position. Place treated brass or TFE-fluorocarbon spacer strip side walls 25 mm (1 in.) high on top of the blocks. Pour material prepared in accordance with Practice D5167 into the space between the blocks in sufficient quantity to bring flush with the top of the side walls. After the specimen has cooled for at least 2 h, remove the excess material protruding beyond the top and bottom of the blocks by cutting it off with a heated metal knife or spatula. Use extreme care when removing the spacers so as not to damage the sealant. If this spacer removal caused defects, if shrinkage of the material upon cooling reduces its level below the top of the concrete blocks, or if other casting defects are apparent, the specimen shall be discarded. The finished specimen should resemble Fig. 2.

9.6 Extension at Low Temperature—Place test specimens, prepared as described in 9.5, in a cold cabinet as described in 9.3.2 for not less than 4 h; then remove the treated spacer

blocks and mount the specimens immediately in the self-aligning clamps of the extension machine. Extend the specimens as required by the respective material specification at a uniform rate of 3.1 ± 0.3 mm (0.125 ± 0.010 in.) per hour. During this period, maintain the atmosphere surrounding the test specimens at the temperature specified in the respective material specification. The specimen shall be removed from the test device within 30 min after completing the extension.

9.7 Recompression—After extension as described in 9.6, remove the specimens from the extension machine and immediately examine the specimens for obvious separations within the sealant and between the sealant and the blocks, without distorting or manually causing extension of the specimens. After inspection replace the spacer strips, return to storage at room temperature for 2 h and rest each specimen on one concrete block so that the weight of the top block recompresses the joint sealant.

9.8 Reextension at Low Temperature and Recompression—After recompression repeat the procedure described in 9.6 and 9.7 to complete the number of cycles of extension and recompression as specified in the respective material specification.

9.9 Evaluation of Bond-Test Results—Within 30 min after the last required extension remove the bond test specimens from the extension machine. Immediately examine the specimens, while still frozen, for obvious separations within the sealant and between the sealant and the blocks, without distorting or manually causing extension of the specimens. Determine conformance to the respective material specification.

9.10 Precision and Bias—No information is presented about precision or bias of this test method for bond evaluation since the results are nonquantitative.

10. Bond, Water-Immersed

10.1 Scope—This test method evaluates bond to concrete after immersion in water.

10.2 Significance and Use—Bond to concrete is necessary for a sealant to maintain for proper field performance. Water immersion can have deleterious affects on the bond to concrete.

10.3 Apparatus:

10.3.1 Extension Machine, as described in 9.3.1.

10.3.2 Cold Chamber, as described in 9.3.2.

10.4 Concrete-Block Preparation:

10.4.1 The concrete blocks shall be prepared in accordance with Practice D1985.

10.5 Specimen Preparation—Prepare three specimens as described in 9.5, replacing the thicker brass or TFE-fluorocarbon spacers with thinner spacers between the concrete blocks so that an opening of not less than 6.4 by 12.7 by 50.8 mm (0.25 by 0.50 by 2 in.) will be produced and maintained between the spacers and the sealant. Then immerse the specimens in suitable covered containers to provide at least a 12.7-mm (0.50-in.) water cover for 96 h in 500 mL (0.53 qt) of distilled or deionized water per specimen and store under standard conditions. Place the specimens in the containers with

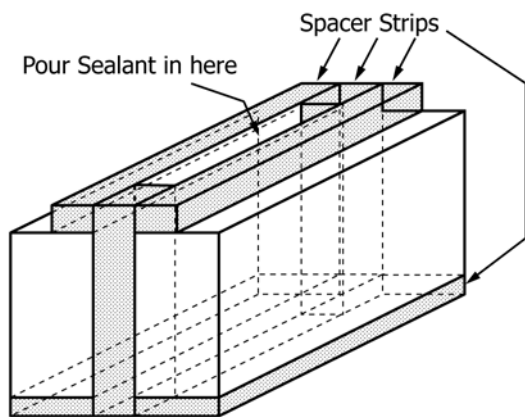

FIG. 1 Concrete Block Mold

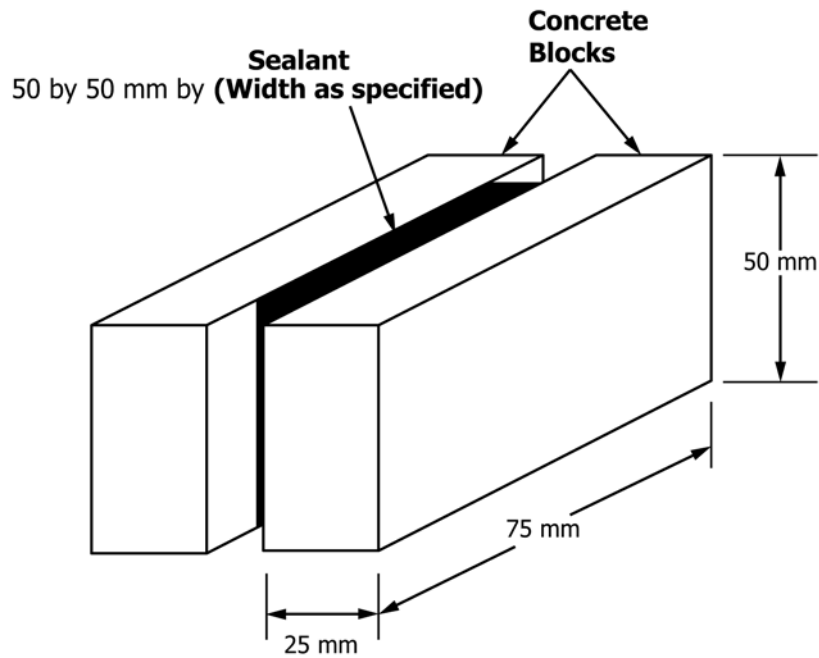

FIG. 2 Concrete Block Test Specimen

the concrete blocks in the horizontal position, resting on the block faces measuring 50 by 76 mm. (2 by 3 in). Three specimens may be placed in one container provided the water to specimen ratio is maintained. At the end of a 96 h water-immersion period, remove the specimens from the water, remove the spacers, and remove the excess surface water from the specimens with a soft, dry, absorbent material. After the surface water has been removed, proceed as described in 9.6.

10.6 *Extension at Low Temperature*—Same as described in 9.6.

10.7 *Recompression*—Same as described in 9.7.

10.8 *Reextension at Low Temperature and Recompression*—Same as described in 9.8.

10.9 *Evaluation of Bond-Test Results*—Same as described in 9.9.

10.10 *Precision and Bias*—No information is presented about precision or bias of this test method for bond evaluation since the results are nonquantitative.

11. Bond, Fuel-Immersed

11.1 *Scope*—This test method evaluates bond to concrete after immersion in reference fuel.

11.2 *Significance and Use*—Bond to concrete is necessary for a sealant to maintain for proper field performance. Fuel immersion, such as could occur on an airport, can have deleterious affects on the bond to concrete.

11.3 *Apparatus:*

11.3.1 *Extension Machine*, as described in 9.3.1.

11.3.2 *Cold Chamber*, as described in 9.3.2.

11.4 *Concrete-Block Preparation:*

11.4.1 The concrete blocks shall be prepared in accordance with Practice D1985.

11.5 *Specimen Preparation*—Prepare three specimens as described in 9.5, and proceed as required in 10.5 but use a fuel cover instead of water for 24 h in at least 500 mL (0.53 qt) of clean test fuel conforming to the requirements of Reference Fuel B of Test Method D471, maintained in a water bath at a constant temperature of $49 \pm 1^\circ\text{C}$ ($120 \pm 2^\circ\text{F}$). Use clean test fuel for each test. At the end of the 24-h immersion period, remove the entire assembly of test specimens, fuel, and containers and condition in an atmosphere at the specified temperature for not less than 4 h. Then subject the specimens to the extension test specified in 9.6.

11.6 *Extension at Low Temperature*—Same as described in 9.6.

11.7 *Recompression*—Same as described in 9.7.

11.8 *Reextension at Low Temperature and Recompression*—Same as described in 9.8.

11.9 *Evaluation of Bond-Test Results*—Same as described in 9.9.

11.10 *Precision and Bias*—No information is presented about precision or bias of this test method for bond evaluation since the results are nonquantitative.

12. Resilience

12.1 *Scope*—This test method measures the ability of a sealant to recover after a steel ball has been forced into the surface.

12.2 *Significance and Use*—The ability of a sealant to reject incompressible objects from its surface is important to the functioning of a sealant.

12.3 *Apparatus*—Conduct this test using the standard penetrometer described in Test Method D5, except replace the needle on this standard penetrometer with a ball penetration

tool shown in Fig. 3 (total weight of the ball penetration tool and penetrometer spindle shall be 75 ± 0.01 g).

12.4 *Specimen Preparation*—Prepare one specimen as specified in Practice D5167 using a 177.5-cm³ (6-oz) tin can. Cure the specimen at the temperature and for the time specified in the respective material specification under standard laboratory conditions prior to testing.

12.5 *Procedure*—Place the tin can specimen in a water bath maintained at $25 \pm 0.1^\circ\text{C}$ ($77 \pm 0.2^\circ\text{F}$) 2 h immediately before testing. Remove the specimen from the water bath, dry the surface and prepare the specimen for testing by coating the surface of the material lightly with talc and blowing off the

excess. Do not test under water. Proceed as follows: Set the indicating dial to zero and place the ball penetration tool in contact with the surface of the specimen by using a light source so that initial contact of the ball and surface of the specimen can be readily seen. Release the ball penetration tool, allow it to penetrate the specimen for 5 s, and record the reading as ball penetration, *P*. Without returning the dial pointer to zero, press the ball penetration tool down an additional 100 units (that is, to a reading of *P* + 100) at a uniform rate in 10 s. Reengage the clutch to hold the tool down for an additional 5 s, and during this time return the dial to zero. Release the clutch, allow the specimen to recover for 20 s, and record the final dial reading,

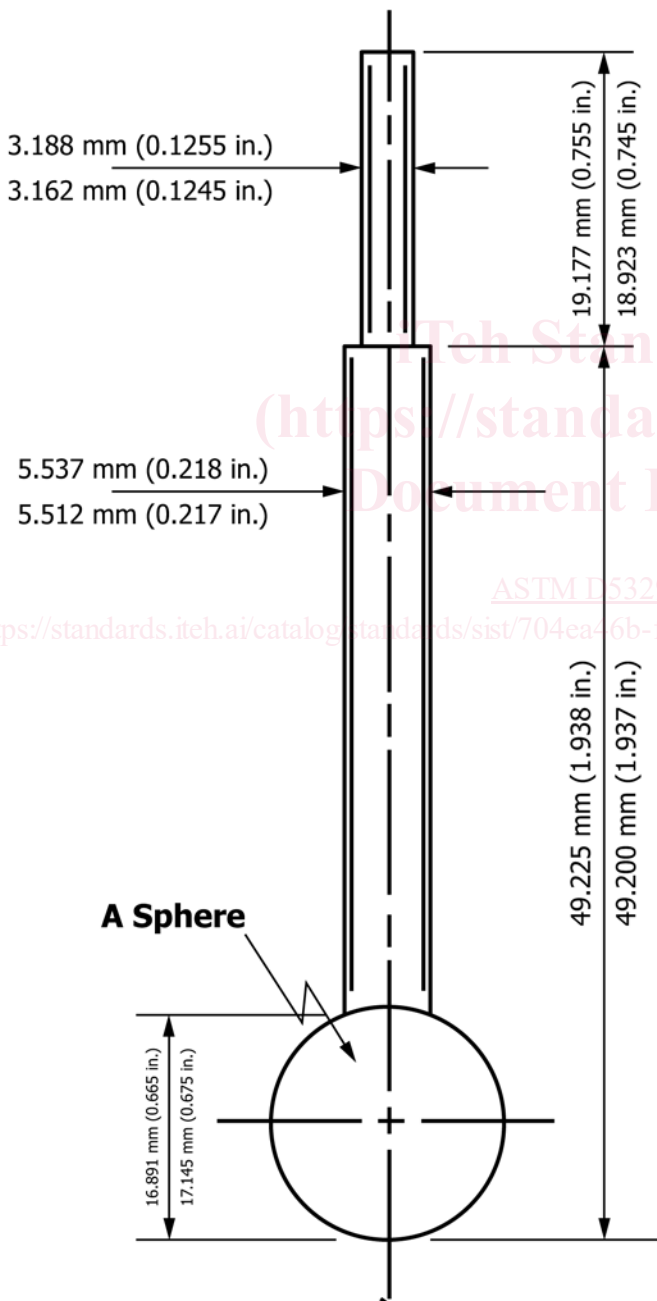

1. **Material: Steel**
2. **Weight of ball & shaft (shown): 27.5 ± 0.01 g**
3. **Total weight of ball, shaft & penetrometer shaft (not shown): 75 ± 0.01 g**
4. **Ball may be screw attached, brazed on or made with shaft.**
5. **Ball finish must be 63 RMS & diameter profile within 0.051 mm (0.002 in.)**

FIG. 3 Ball Penetration Tool