



Designation: E1473-03 Designation: E 1473 - 09

Standard Test Methods for Chemical Analysis of Nickel, Cobalt, and High-Temperature Alloys¹

This standard is issued under the fixed designation E 1473; the number immediately following the designation indicates the year of original adoption or, in the case of revision, the year of last revision. A number in parentheses indicates the year of last reapproval. A superscript epsilon (ϵ) indicates an editorial change since the last revision or reapproval.

1. Scope

1.1 These test methods describe the chemical analysis of nickel, cobalt, and high-temperature alloys having chemical compositions within the following limits:

Element	Concentration Range, %
Aluminum	0.005 to 7.00
Beryllium	0.001 to 0.05
Boron	0.001 to 1.00
Calcium	0.002 to 0.05
Carbon	0.001 to 1.10
Chromium	0.10 to 33.00
Cobalt	0.10 to 75.00
Copper	0.01 to 35.00
Iron	0.01 to 50.00
Lead	0.001 to 0.01
Magnesium	0.001 to 0.05
Manganese	0.01 to 3.0
Molybdenum	0.01 to 30.0
Niobium (Columbium)	0.01 to 6.0
Nickel	0.10 to 98.0
Nitrogen	0.001 to 0.20
Phosphorus	0.002 to 0.08
Sulfur	0.002 to 0.10
Silicon	0.01 to 5.00
Tantalum	0.005 to 1.00
Tin	0.002 to 0.10
Titanium	0.01 to 5.00
Tungsten	0.01 to 18.00
Vanadium	0.01 to 3.25
Zinc	0.001 to 0.01
Zirconium	0.01 to 2.50

iTeh Standards
(<https://standards.itih>)
Document Preview

ASTM E1473-09

<https://standards.itih.ai/catalog/standards/sist/cc46237d-d14e-4f58-9e2b-94d797749823/astm-e1473-09>

1.2 The test methods in this standard are contained in the sections indicated as follows:

Method	Sections
<u>Aluminum, Total by the 8-Quinolinol Gravimetric Method (0.20 to 7.00 %)²</u>	<u>62 to 69</u>
<u>Aluminum, Total by the 8-Quinolinol Gravimetric Method (0.20 % to 7.00 %)²</u>	<u>62 to 69</u>
<u>Chromium by the Atomic Absorption Method (0.018 to 1.00 %)²</u>	<u>100 to 109</u>
<u>Chromium by the Atomic Absorption Method (0.018 % to 1.00 %)²</u>	<u>100 to 109</u>
<u>Chromium by the Peroxydisulfate Oxidation—Titration Method (0.10 to 33.00 %)²</u>	<u>110 to 118</u>
<u>Chromium by the Peroxydisulfate Oxidation—Titration Method (0.10 % to 33.00 %)²</u>	<u>110 to 118</u>
<u>Cobalt by the Ion-Exchange-Potentiometric Titration Method (2 to 75 %)²</u>	<u>34 to 41</u>
<u>Cobalt by the Ion-Exchange-Potentiometric Titration Method (2 % to 75 %)²</u>	<u>34 to 41</u>
<u>Cobalt by the Nitroso-R-Salt Photometric Method (0.10 to 5.0 %)²</u>	<u>42 to 51</u>

¹ These test methods are under the jurisdiction of ASTM Committee E01 on Analytical Chemistry for Metals, Ores, and Related Materials and are the direct responsibility of Subcommittee E01.08 on Ni and Co and High-Temperature Alloys.

Current edition approved December 1, 2003; 2009. Published January 2004; July 2009. Originally approved in 1992. Last previous edition approved in 1998 as E1473-94a (1998); E 1473 - 03.

<u>Cobalt by the Nitroso-R-Salt Photometric Method</u> (0.10 % to 5.0 %)²	42 to 51
<u>Copper by Neocuproine Photometric Method (0.010 to 10.00-%)²</u>	52 to 61
<u>Copper by Neocuproine Photometric Method (0.010 % to 10.00 %)²</u>	52 to 61
<u>Iron by the Silver Reduction Titrimetric Method—</u> <u>(1.0 to 50.0 %)²</u>	127 to 134
<u>Iron by the Silver Reduction Titrimetric Method</u> (1.0 % to 50.0 %)²	127 to 134
<u>Manganese by the Metaperiodate Photometric Method (0.05 to</u> <u>2.00 %)²</u> 8 to 17	8 to 17
<u>Manganese by the Metaperiodate Photometric Method (0.05 % to</u> <u>2.00 %)²</u>	8 to 17
<u>Molybdenum by the Ion Exchange—8-Hydroxyquinoline Gravi-</u> <u>metric Method (1.5 to 30 %)²</u>	119 to 126
<u>Molybdenum by the Ion Exchange—8-Hydroxyquinoline</u> <u>Gravimetric Method (1.5 % to 30 %)²</u>	119 to 126
<u>Molybdenum by the Photometric Method—</u> <u>(0.01 to 1.50 %)²</u> 88 to 99	88 to 99
<u>Molybdenum by the Photometric Method</u> (0.01 % to 1.50 %)²	88 to 99
<u>Nickel by the Dimethylglyoxime Gravimetric Method (0.1 to</u> <u>84.0 %)²</u>	70 to 77
<u>Nickel by the Dimethylglyoxime Gravimetric Method</u> (0.1 % to 84.0 %)²	70 to 77
<u>Niobium by the Ion Exchange—Cupferron Gravimetric Method</u> <u>(0.5 to 6.0 %)</u>	135 to 142
<u>Niobium by the Ion Exchange—Cupferron Gravimetric Method</u> (0.5 % to 6.0 %)	135 to 142
<u>Silicon by the Gravimetric Method (0.05 to 5.00 %)²</u>	27 to 33
<u>Silicon by the Gravimetric Method (0.05 % to 5.00 %)²</u>	27 to 33
<u>Sulfur by the Combustion-Iodate Titration Method (0.006 to</u> <u>0.1 %)²</u>	18 to 26
<u>Sulfur by the Combustion-Iodate Titration Method</u> (0.006 % to 0.1 %)²	18 to 26
<u>Tantalum by the Ion Exchange—Pyrogallol Spectrophotometric</u> <u>Method (0.03 to 1.0 %)</u>	143 to 151
<u>Tantalum by the Ion Exchange—Pyrogallol Spectrophotometric</u> <u>Method (0.03 % to 1.0 %)</u>	143 to 151
<u>Tin by the Solvent Extraction-Atomic Absorption Method (0.002</u> <u>to 0.10 %)²</u>	78 to 87
<u>Tin by the Solvent Extraction-Atomic Absorption Method</u> (0.002 % to 0.10 %)²	78 to 87

1.3 Methods for the determination of several elements not included in these test methods can be found in Test Methods E30, E76, and E1019E 30, E 76, and E 1019.

1.4 Some of the concentration ranges given in 1.1 are too broad to be covered by a single method, and therefore, these test methods contain multiple methods for some elements. The user must select the proper test method by matching the information given in the scope and interference sections of each test method with the composition of the alloy to be analyzed.

1.5 The values stated in SI units are to be regarded as standard. In some cases, exceptions allowed in Practice E 380 are also used.

1.6 *This standard does not purport to address all of the safety concerns, if any, associated with its use. It is the responsibility of the user of this standard to establish appropriate safety and health practices and determine the applicability of regulatory limitations prior to use.* Specific hazard statements are given in Section 7 and in special caution and warning paragraphs throughout these test methods, and in 13.4, 29.1, 66.3, 123.5, 124.14, 139.4, 139.5, 147.5, and 147.6.

2. Referenced Documents

2.1 ASTM Standards:³

D 1193 [Specification for Reagent Water](#)

E 29 [Practice for Using Significant Digits in Test Data to Determine Conformance with Specifications](#)

E 30 [Test Methods for Chemical Analysis of Steel, Cast Iron, Open-Hearth Iron, and Wrought Iron](#)⁴

E 50 [Practices for Apparatus, Reagents, and Safety Precautions for Chemical Analysis of Metals](#) Practices for Apparatus, Reagents, and Safety Considerations for Chemical Analysis of Metals, Ores, and Related Materials

E59 [Practice for Sampling Steel and Iron for Determination of Chemical Composition](#)

² These test methods were extracted from Test Methods E 354 and the references to Test Methods E350, E351, E352, and E353 and the references to Test Methods E 350, E 351, E 352, and E 353 contained therein.

³ For referenced ASTM standards, visit the ASTM website, www.astm.org, or contact ASTM Customer Service at service@astm.org. For *Annual Book of ASTM Standards* volume information, refer to the standard's Document Summary page on the ASTM website.

⁴ Withdrawn. The last approved version of this historical standard is referenced on www.astm.org.

- ~~E 60 Practice for Photometric and Spectrophotometric Methods for Chemical Analysis of Metals~~
- ~~Practice for Analysis of Metals, Ores, and Related Materials by Molecular Absorption Spectrometry~~
- ~~E 76 Test Methods for Chemical Analysis of Nickel-Copper Alloys~~
- ~~E 135 Terminology Relating to Analytical Chemistry for Metals, Ores, and Related Materials~~
- ~~E 173 Practice for Conducting Interlaboratory Studies of Methods for Chemical Analysis of Metals⁰~~
- ~~E 350 Test Methods for Chemical Analysis of Carbon Steel, Low-Alloy Steel, Silicon Electrical Steel, Ingot Iron, and Wrought Iron~~
- ~~E 351 Test Methods for Chemical Analysis of Cast Iron—All Iron All Types~~
- ~~E 352 Test Methods for Chemical Analysis of Tool Steels and Other Similar Medium- and High-Alloy Steels~~
- ~~E 353 Test Methods for Chemical Analysis of Stainless, Heat-Resisting, Maraging, and Other Similar Chromium-Nickel-Iron Alloys~~
- ~~E 354 Test Methods for Chemical Analysis of High-Temperature, Electrical, Magnetic, and Other Similar Iron, Nickel, and Cobalt Alloys~~
- ~~E 380 Practice for Use of the International System of Units (SI) (the Modernized Metric System)⁰~~
- ~~E 882 Guide for Accountability and Quality Control in the Chemical Analysis Laboratory~~
- ~~E 1019 Test Methods for Determination of Carbon, Sulfur, Nitrogen, and Oxygen in Steel and in Iron, Nickel, and Cobalt Alloys~~
- ~~E1024 Guide for Chemical Analysis of Metals and Metal Bearing Ores by Flame Atomic Absorption Spectrophotometry~~
- ~~E1097 Guide for Direct Current Plasma Emission Spectrometry Analysis~~

~~2.2 Other Document:~~

~~ISO5725 Precision of Test Methods—Determination of Repeatability and Reproducibility for Inter-Laboratory Tests—Test Methods for Determination of Carbon, Sulfur, Nitrogen, and Oxygen in Steel, Iron, Nickel, and Cobalt Alloys by Various Combustion and Fusion Techniques~~

3. Significance and Use

~~3.1 These test methods for the chemical analysis of metals and alloys are primarily intended as referee methods to test such materials for compliance with compositional specifications, particularly those under the jurisdiction of ASTM Committee B-2 on Nonferrous Metals and Alloys. It is assumed that all who use these test methods will be trained analysts capable of performing common laboratory procedures skillfully and safely. It is expected that work will be performed in a properly equipped laboratory under appropriate quality control practices such as those described in Guide E882 Terminology~~

~~3.1 Definitions: Definitions—For definitions of terms used in these test methods, refer to Terminology E 135.~~

4. Significance and Use

~~4.1 These test methods for the chemical analysis of metals and alloys are primarily intended as referee methods to test such materials for compliance with compositional specifications, particularly those under the jurisdiction of ASTM Committee B02 on Nonferrous Metals and Alloys. It is assumed that all who use these test methods will be trained analysts capable of performing common laboratory procedures skillfully and safely. It is expected that work will be performed in a properly equipped laboratory under appropriate quality control practices such as those described in Guide E 882.~~

5. Apparatus, Reagents, and Instrumental Practice

~~4.1~~

~~5.1 Apparatus—Specialized apparatus requirements are listed in the Apparatus section in each test method. In some cases, reference may be made to Practices E 50.~~

~~4.2~~

~~5.2 Reagents:~~

~~4.2.1~~

~~5.2.1 Purity of Reagents—Unless otherwise indicated, all reagents used in these test methods shall conform to the specifications of the Committee on Analytical Reagents of the American Chemical Society where such specifications are available.⁵ Other chemicals may be used, provided it is first ascertained that they are of sufficiently high purity to permit their use without adversely affecting the expected performance of the determination, as indicated in the Precision and Bias sections.~~

~~4.2.2.2 Purity of Water—Unless otherwise indicated, references to water shall be understood to mean reagent water as defined by Type II of Specification D 1193.~~

~~4.3~~

~~5.3 Photometric Practice—Photometric practice prescribed in these test methods shall conform to Practice E 60.~~

⁵ *Reagent Chemicals, American Chemical Society Specifications*, American Chemical Society, Washington, DC. For suggestions on the testing of reagents not listed by the American Chemical Society, see *Analar Standards for Laboratory Chemicals*, BDH Ltd., Poole, Dorset, U.K., and the *United States Pharmacopeia and National Formulary*, U.S. Pharmaceutical Convention, Inc. (USPC), Rockville, MD; Reagent Chemicals, American Chemical Society Specifications, American Chemical Society, Washington, DC, <http://pubs.acs.org/reagents/index.html>. For suggestions on the testing of reagents not listed by the American Chemical Society, see the *United States Pharmacopeia and National Formulary*, U.S. Pharmacopeial Convention, Inc. (USPC), Rockville, MD, <http://www.usp.org>.

5. Sampling

5.1 For procedures for sampling the material, reference shall be made to Method E59.

6. Interlaboratory Studies and Rounding Calculated Values

6.1 These test methods have been evaluated using Practice E 173 or ISO 5725.

6.2 Round calculated values to the desired number of places as directed in 3.4 to 3.6 of Practice E 29.

7. Hazards

7.1 For precautions to be observed in the use of certain reagents and equipment in these test methods, refer to Practices E 50.

MANGANESE BY THE METAPERIODATE PHOTOMETRIC METHOD

8. Scope

8.1 This test method covers the determination of manganese in concentrations from 0.05 % to 2.00 %.

9. Summary of Test Method

9.1 Manganous ions are oxidized to permanganate ions by treatment with periodate. Tungsten when present at concentrations greater than 0.5 % is kept in solution with phosphoric acid (H_3PO_4). Solutions of the samples are fumed with perchloric acid so that the effect of periodate is limited to the oxidation of manganese. Photometric measurements are made at 545 nm.

10. Concentration Range

10.1 The recommended concentration range is from 0.15 mg to 0.8 mg of manganese per 50 mL of solution, using a 1-cm cell (Note 1) and a spectrophotometer with a band width of 10 nm or less.

NOTE 1—This test method has been written for cells having a 1-cm light path and a “narrow-band” instrument. The concentration range depends upon band width and spectral region used as well as cell optical path length. Cells having other dimensions may be used, provided suitable adjustments can be made in the amounts of sample and reagents used.

11. Stability of Color

11.1 The color is stable for at least 24 h.

12. Interferences

12.1 Perchloric acid treatment, which is used in the procedure, yields solutions which can be highly colored due to the presence of hexavalent chromium (Cr(VI)) ions. Although these ions and other colored ions in the sample solution undergo no further change in color quality upon treatment with metaperiodate ion, the following precautions must be observed when filter photometers are used: Select a filter with maximum transmittance between 545 nm and 565 nm. The filter must transmit not more than 5 % of its maximum at a wavelength shorter than 530 nm. The band width of the filter should be less than 30 nm when measured at 50 % of its maximum transmittance. Similar restrictions apply with respect to the wavelength region employed when other “wide-band” instruments are used.

12.2 The spectral transmittance curve of permanganate ions exhibits two useful minima, one at approximately 526 nm, and the other at 545 nm. The latter is recommended when a “narrow-band” spectrophotometer is used.

12.3 Tungsten, when present in amounts of more than 0.5 % interferes by producing a turbidity in the final solution. A special procedure is provided for use with samples containing more than 0.5 % tungsten which eliminates the problem by preventing the precipitation of the tungsten.

13. Reagents

13.1 *Manganese, Standard Solution (1 mL = 0.032 mg Mn)*—Transfer the equivalent of 0.4000 g of assayed, high-purity manganese (purity 99.99 % minimum), to a 500-mL volumetric flask and dissolve in 20 mL of HNO_3 by heating. Cool, dilute to volume, and mix. Using a pipet, transfer 20 mL to a 500-mL volumetric flask, dilute to volume, and mix.

13.2 *Nitric-Phosphoric Acid Mixture*—Cautiously, while stirring, add 100 mL of HNO_3 and 400 mL of H_3PO_4 to 400 mL of water. Cool, dilute to 1 L, and mix. Prepare fresh as needed.

13.3 *Potassium Metaperiodate Solution (7.5 g/L)*—Dissolve 7.5 g of potassium metaperiodate (KIO_4) in 200 mL of hot HNO_3 (1 + 1), add 400 mL of H_3PO_4 , cool, dilute to 1 L, and mix.

13.4 *Water, Pretreated with Metaperiodate*—Add 20 mL of KIO_4 solution to 1 L of water, mix, heat at not less than 90 °C for 20 to 30 min, and cool. Use this water to dilute solutions to volume that have been treated with KIO_4 solution to oxidize manganese, and thus avoid reduction of permanganate ions by any reducing agents in the untreated water. ~~Caution—Avoid~~ **(Warning—Avoid** the use of this water for other purposes.)

14. Preparation of Calibration Curve

14.1 *Calibration Solutions*—Using pipets, transfer (5, 10, 15, 20, and 25) mL of manganese standard solution (1 mL = 0.032 mg Mn) to 50-mL borosilicate glass volumetric flasks, and, if necessary, dilute to approximately 25 mL. Proceed as directed in 14.3.

14.2 *Reference Solution*—Transfer approximately 25 mL of water to a 50-mL borosilicate glass volumetric flask. Proceed as directed in 14.3

14.3

14.3 *Color Development*—Add 10 mL of KIO_4 solution, and heat the solutions at not less than 90 °C for 20 to 30 min (Note 2). Cool, dilute to volume with pretreated water, and mix.

NOTE 2—Immersing the flasks in a boiling water bath is a preferred means of heating them for the specified period to ensure complete color development.

14.4 *Photometry*:

14.4.1 *Multiple-Cell Photometer*—Measure the cell correction using the Reference Solution (14.2) in absorption cells with a 1-cm light path and using a light band centered at approximately 545 nm. Using the test cell, take the photometric readings of the calibration solutions versus the reference solution (14.2).

14.4.2 *Single-Cell Photometer*—Transfer a suitable portion of the reference solution (14.2) to an absorption cell with a 1-cm light path and adjust the photometer to the initial setting, using a light band centered at approximately 545 nm. While maintaining this adjustment, take the photometric readings of the calibration solutions.

14.5 *Calibration Curve*—Plot the net photometric readings of the calibration solutions against milligrams of manganese per 50 mL of solution.

15. Procedure

15.1 *Test Solutions*—Select and weigh a sample in accordance with the following:

Manganese, %	Sample Weight, g	Tolerance in Sample Weight, mg	Dilution, mL
0.01 to 0.5	0.80	0.5	100
0.45 to 1.0	0.35	0.3	100
0.85 to 2.0	0.80	0.5	500

15.1.1 *For Samples Containing Not More Than 0.5 % Tungsten*:

15.1.1.1 To dissolve samples that do not require HF, add 8 mL to 10 mL of HCl (1 + 1), and heat. Add HNO_3 as needed to hasten dissolution, and then add 3 mL to 4 mL in excess. When dissolution is complete, cool, then add 10 mL of HClO_4 ; evaporate to fumes to oxidize chromium, if present, and to expel HCl. Continue fuming until salts begin to separate. Cool, add 50 mL of water, and digest if necessary to dissolve the salts. Cool and transfer the solution to a 100-mL volumetric flask. Proceed to 15.1.3.

15.1.1.2 For samples whose dissolution is hastened by HF, add 8 mL to 10 mL of HCl (1 + 1), and heat. Add HNO_3 and a few drops of HF as needed to hasten dissolution, and then add 3 mL to 4 mL of HNO_3 . When dissolution is complete, cool, then add 10 mL of HClO_4 , evaporate to fumes to oxidize chromium, if present, and to expel HCl. Continue fuming until salts begin to separate. Cool, add 50 mL of water, digest if necessary to dissolve the salts, cool, and transfer the solution to either a 100-mL or 500-mL volumetric flask as indicated in 15.1.5.1.1. Proceed to 15.1.3.

15.1.2 *For Samples Containing More Than 0.5 % Tungsten*:

15.1.2.1 To dissolve samples that do not require HF, add 8 mL to 10 mL of H_3PO_4 , 10 mL of HClO_4 , 5 to 6 mL of H_2SO_4 , and 3 to 4 mL of HNO_3 , and 3 mL to 4 mL of HNO_3 . Heat moderately until the sample is decomposed, and then heat to copious white fumes for 10 to 12 min or until the chromium is oxidized and the HCl is expelled, but avoid heating to fumes of sulfur trioxide (SO_3). Cool, add 50 mL of water, and digest, digest if necessary; to dissolve the salts. Transfer the solution to either a 100-mL or 500-mL volumetric flask as directed in 15.1. Proceed to 15.1.3.

15.1.2.2 For samples whose dissolution is hastened by HF: Add 8 to 10 mL of H

15.1.2.2 For samples whose dissolution is hastened by HF, add 8 mL to 10 mL of H_3PO_4 , 10 mL of HClO_4 , 5 to 6 mL of H_2SO_4 , 3 to 4 mL of HNO_3 , 3 mL to 4 mL of HNO_3 , and a few drops of HF. Heat moderately until the sample is decomposed, and then heat to copious white fumes for 10 to 12 min or until the chromium is oxidized and the HCl is expelled, but avoid heating to fumes of SO_3 . Cool, add 50 mL of water, digest, digest if necessary; to dissolve the salts, cool, and transfer the solution to a 100-mL or 500-mL volumetric flask as directed in 15.1. Proceed to 15.1.3.

15.1.2.3 Cool the solution, dilute to volume, and mix. Allow insoluble matter to settle, or dry-filter through a coarse paper and discard the first 15 to 20 mL of the filtrate, before taking aliquots.

15.1.3 Using a pipet, transfer 20-mL aliquots to two 50-mL borosilicate glass volumetric flasks; treat one as directed in 15.3 and the other as directed in 15.4.1.

15.2 *Reagent Blank Solution*—Carry a reagent blank through the entire procedure using the same amounts of all reagents with the sample omitted.

15.3 *Color Development*—Proceed as directed in 14.3.

15.4 *Reference Solutions*:

15.4.1 *Background Color Solution*—To one of the sample aliquots in a 50-mL volumetric flask, add 10 mL of nitric-phosphoric acid mixture, and heat the solution at not less than 90 °C for 20 to 30 min (Note 2). Cool, dilute to volume (with untreated water), and mix.

15.4.2 *Reagent Blank Reference Solution*—Transfer the reagent blank solution (15.2) to the same size volumetric flask as used

for the test solutions and transfer the same size aliquots as used for the test solutions to two 50-mL volumetric flasks. Treat one portion as directed in 15.3 and use as reference solution for test samples. Treat the other as directed in 15.4.1 and use as reference solution for background color solutions.

15.5 *Photometry*—Establish the cell corrections with the reagent blank Reference solution to be used as a reference solution for background color solutions. Take the photometric readings of the background color solutions and the test solutions versus the respective reagent blank reference solutions as directed in 14.4.

16. Calculation

16.1 Convert the net photometric reading of the test solution and of the background color solution to milligrams of manganese by means of the calibration curve. Calculate the percent of manganese as follows:

Manganese

$$\text{Manganese, \%} = (A - B)/(C \times 10) \quad (1)$$

where:

A = manganese found in 50 mL of the final test solution, mg,

B = apparent manganese found in 50 mL of the final background color solution, mg, and

C = sample weight represented in 50 mL of the final test solution, g.

17. Precision and Bias

17.1 *Precision*—Nine laboratories cooperated in testing this test method and obtained the data summarized in Table 1.

17.2 *Bias*—No information on the accuracy of this test method is known. The accuracy of this test method may be judged by comparing accepted reference values with the corresponding arithmetic average obtained by interlaboratory testing.

TABLE 2 1 Statistical Information—Sulfur Manganese by the Metaperiodate Photometric Method

Test Material	Sulfur Manganese Found, %	Repeatability (R_1 , Practice E 173A)	Reproducibility (R_2 , Practice E 173A)
Induction Furnace			
1. No. 1, E 352	0.006 ^B	0.0016	0.0032
1. Nickel alloy, 77Ni-20Cr	0.074	0.002	0.0032
2. No. 2, E 352	0.008 ^B	0.0013	0.0044
3. No. 3, E 35-0 (NIST 169, 0.073 Mn)	0.014 ^B	0.0025	0.0029
4. No. 4, E 350	0.016 ^B	0.0018	0.0024
2. High-temperature alloy 5. No. 6, E 350 68Ni-14Cr-7Al-6Mo	0.289	0.007	0.026
6. No. 7, E 35-0 (NIST 1205, 0.29 Mn)	0.032 ^C	0.0032	0.0049
7. Stainless steel 13Cr-0.3Mo (NIST 133a, 0.329S + NBS —10g, 0.109S: 0.286S)	0.141 ^D	0.0066	0.0126
3. Cobalt alloy 41Co	0.286 ^E	0.0135	0.0201
Resistance Furnace			
Resistance Furnace 8			
1. No. 1, E 352 20Ni-20Cr-4Mo-4W	0.006 ^B	0.0014	0.0024
2. No. 2, E 352 (NIST 168, 1.50 Mn)	0.009 ^B	0.0007	0.0020
3. No. 3, E 350	0.014 ^B	0.0014	0.0025
4. Stainless steel 18Cr-9Ni 4. No. 4, E 350 (NIST 101e, 1.77 Mn)	1.79	0.07	0.07
5. No. 6, E 350	0.015 ^B	0.0017	0.0029
6. No. 7, E 350	0.032 ^C	0.0028	0.0041
7. Stainless steel 13Cr-0.3Mo (NIST 133a, 0.329S + NBS —10g, 0.109S: 0.286S)	0.140 ^D	0.0074	0.0111
	0.288 ^E	0.0123	0.0206

^AThis test method was performed in accordance with the 1980 version of Practice E173.

^BCalibration standards: See Footnote ^A, Table 5, Test Methods E350.

^CCalibration standards: See Footnote ^B, Table 5, Test Methods E350.

^DCalibration standards: See Footnote ^C, Table 5, Test Methods E350.

^ECalibration standards: See Footnote ^D, Table 5, Test Methods E350.

TABLE 1.2 Statistical Information—Manganese by the Metaperiodate Photolumetric Method

Test-Sp Material	Manganese Found, %	Repeatability (R_1 , Practice E 173 ^A)	Reproducibility (R_2 , Practice E 173 ^A) ¹ —Nickel alloy; 77Ni-20Cr	0.074	0.002
(NIST 169, 0.073Mn)		2. High-temperature	alloy	0.289	0.0070.026
1. NIST SRM 168 (41Co, 20Cr, 20Ni, 4Mo, 4W, 3Fe, 2Mn, 1Si) (0.95Ta, certified)	0.94	0.1821		0.289	0.007
(68Ni-14Cr-7Al-6Mo)		(NIST 1205, 0.29Mn)			
2. NIST 1203 (76Ni, 12Cr, 4Al, 3Mo, 1Ti, 1Si) (0.34Ta, certified)	0.35	0.1010		7	
3. Cobalt alloy 41Co	1.49	0.0008	20Ni-20Cr-4Mo-4W	7	
3. BAM 328-1 (42Co, 21Cr, 20Ni, 4Mo, 4W, 2Fe, 1Mn, 1Si) (0.18Ta, certified)	0.17	0.0008		7	
4. NIST SRM 123 (70Fe, 18Cr, 11Ni) (0.027Ta, certified)	(NIST 168, 1.50Mn) 0.028	0.00009		5	
4. Stainless steel 18Cr-9Ni	1.79	0.0007			
5. Nickel-base alloy (53Ni, 19Cr, 18Fe, 3Mo, 1Ti) (0.012Ta, estimated)	0.010	0.0007			
(NIST 401e, 1.77 Mn)					
(NIST 108)	4				

^A This test was performed in accordance with the 1992 version of Practice E 173.

^B Number of independent data sets.

SULFUR BY THE COMBUSTION-IODATE TITRATION METHOD

18. Scope

18.1 This test method covers the determination of sulfur in concentrations from 0.006 % to 0.1 %.

19. Summary of Test Method

19.1 A major part of the sulfur in the sample is converted to sulfur dioxide (SO₂) by combustion in a stream of oxygen. During the combustion, the SO₂ is absorbed in an acidified starch-iodide solution and titrated with potassium iodate solution. The latter is standardized against steels of known sulfur content to compensate for characteristics of a given apparatus and for day-to-day variation in the percentage of sulfur recovered as SO₂. Compensation is made for the blank due to accelerators and boats (or crucibles).

20. Interferences

20.1 The elements ordinarily present do not interfere if their concentrations are under the maximum limits shown in 1.1.

21. Apparatus

21.1 *Apparatus for Determination of Sulfur by Direct Combustion*—The apparatus must be suitable for the combustion of the sample in oxygen to form sulfur dioxide (SO₂) and must provide an absorption vessel in which the SO₂ is titrated. A typical arrangement is shown in Fig. 1.

21.1.1 *Oxygen Purifiers*—The regular commercial tank oxygen is satisfactory. It must be passed through two pressure reduction valves (approximately 207 kPa (30 psig) and 14 kPa to 28 kPa (2 psig to 4 psig), respectively) or a suitable two-stage reduction

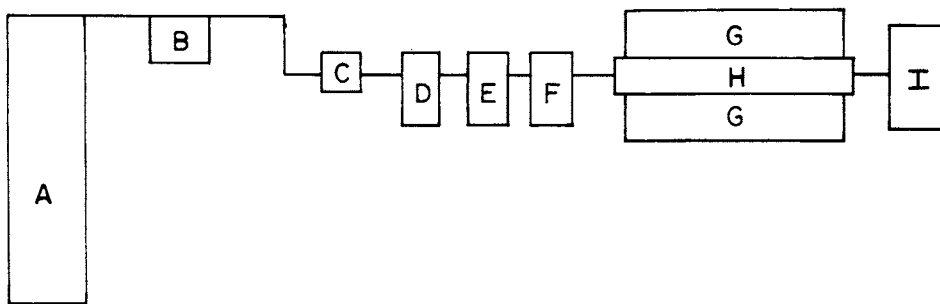

- A — Oxygen tank
- B — Reduction valve
- C — Quick-acting shut-off valve
- D — Tower containing H₂SO₄
- E — Tower containing CO₂ absorber and anhydrous Mg(ClO₄)₂
- F — Flowmeter.
- G — Furnace, induction or resistance-type
- H — Combustion tube
- I — Absorption and titration assembly

FIG. 1 Typical Arrangement for Determination of Sulfur by the Direct-Combustion Method

valve to provide an even and adequate flow of oxygen through a tower containing H_2SO_4 and through an absorption tower containing 20 to 30-mesh inert base impregnated with sodium hydroxide (NaOH) and anhydrous magnesium perchlorate ($Mg(ClO_4)_2$). A flowmeter and quick-acting shut-off valve for use during preheating periods must precede the resistance furnace assembly. A flowmeter must also precede the induction furnace assembly.

21.1.2 Combustion Furnace—An electric tube furnace capable of continuous operation at $1425\text{ }^\circ\text{C}$ to $1450\text{ }^\circ\text{C}$ is recommended, since this temperature is required for some alloys. The combustion may be accomplished either by resistance or induction heating. With the former, the temperature must be controlled as specified for each type of alloy. With the latter a rheostat to control the power input to the induction coil is required to avoid heating some types of samples too rapidly during the early stages of combustion. The combustion zone of the resistance furnace must be 200 mm to 250 mm (8 in. to 10 in.) in length and that of the induction furnace must amply provide for adequate heating of the sample.

21.1.3 Combustion Tube—The combustion tube of the resistance furnace must be of a low-sulfur refractory type that will withstand the maximum operating temperature without becoming porous. The tube must be of a suitable size to fit the particular furnace used and have an inside diameter large enough to accommodate the thimble, boat, and cover. A tapered-end tube is recommended.

21.1.4 Combustion Boats, Crucibles, and Covers—The boats and crucibles for use with the respective types of furnaces must be of adequate thickness to retain the molten slag and have a blank as low and consistent as possible. The boats for use with resistance furnaces should be 90 mm to 100 mm (3.5 in. to 4 in.) in length and may be provided with suitable covers. The crucibles for use with induction furnaces must have adequate capacity and may be provided with suitable covers. The blank requirements that apply to the boats and crucibles also apply to their covers. Prior to use, the boats and covers must be pre-fired at least 15 min at $1100\text{ }^\circ\text{C}$ and then stored in a desiccator.

21.1.5 Ceramic Thimble—A porous ceramic thimble or liner with a small orifice drilled in the closed end is placed (closed end first) in the hot zone of the tube of the resistance furnace to prolong the life of the combustion tube by absorbing spattered slag, slag and to act as a filter to remove metal oxide fumes from the gas stream.

21.1.6 Ceramic Filter—If a ceramic thimble is not available, a porous ceramic filter is placed in the hot zone of the furnace to remove metallic oxide fumes from the gas stream; it can be constructed from porous insulating fire brick capable of withstanding the operating temperatures. In induction furnaces, suitable precautions must be taken to prevent metallic oxides from entering the titration vessel.

21.1.7 Connections—A metal breech connector at the entrance of the combustion tube is recommended. If a rubber stopper is used it must be protected by heat-reflecting baffles, preferably of the double-disk type. Connection between the outlet end of the combustion tube and the absorption and titration assembly must be as short and free of bends as possible, with glass connections butted to minimize areas of rubber tubing exposed to gases. All rubber stoppers and tubing must be essentially free of sulfur.

21.1.8 Absorption and Titration Apparatus—The apparatus should consist of an absorption and titration vessel of appropriate volume and containing an inlet bubbler tube for the sulfur gases with a float valve to prevent back flow of liquid when the sample is starting to consume oxygen. The vessel must be shaped to effect complete absorption of SO_2 in a small volume of solution. The buret should be approximately 10 mL in capacity. Automatic titrations which utilize a photoelectric cell to activate a solution inlet valve are commercially available and may be used.

22. Reagents

22.1 Copper (Low-Sulfur) Accelerator—Rectangular strips for combustion boats used with a resistance furnace, or rings for crucibles used with an induction furnace.

22.2 Iron (Low-Sulfur) Accelerator—Iron chips or iron powder.

22.3 Potassium Iodate Standard Solution A (Approximate sulfur equivalent = 0.1 mg S/mL)—Dissolve 0.2225 g of potassium iodate (KIO_3) (Approximate Sulfur Equivalent = 0.1 mg S/mL)—Dissolve 0.2225 g of potassium iodate (KIO_3) in 900 mL of water containing 1 g of sodium hydroxide (NaOH) and dilute to 1 L. in 900 mL of water containing 1 g of NaOH and dilute to 1 L.

22.4 Potassium Iodate Standard Solution B (Approximate sulfur equivalent = 0.02 mg S/mL). Transfer 200 mL of KIO_3 Potassium Iodate Standard Solution A (Approximate Sulfur Equivalent = 0.02 mg S/mL)—Transfer 200 mL of KIO_3 Standard Solution A (Approximate sulfur equivalent = 0.1 mg S/mL) to a 1-L volumetric flask, dilute to volume, and mix.

NOTE 3—The stated sulfur equivalents are based on complete conversion of sulfur to SO_2 ; this is a phenomenon that seldom, if ever, occurs.

22.5 Starch-Iodide Solution—Transfer 9 g of soluble (or arrowroot) starch to a 50-mL beaker, add 5 mL to 10 mL of water, and stir until a smooth paste is obtained. Pour the mixture slowly into 500 mL of boiling water. Cool, add 15 g of potassium iodide (KI), and stir until the KI is dissolved. Dilute to 1 L .

22.6 Tin (Low-Sulfur) Accelerator, granular.

23. Calibration

23.1 Select a minimum of three standards (Note 6), two with sulfur contents near the high and low limits of the range for a given sample weight (24.1.3) and also one near the median. The median standard may be simulated, if necessary, by taking one half the sample weight of each of the other two.

NOTE 4—The accuracy of this test method is dependent to a large extent upon the accuracy of the methods used to certify the sulfur concentration in the calibration standards.

23.2 For sulfur concentrations greater than 0.02 % use KIO₃ Standard Solution A. For sulfur concentrations less than 0.02 % use KIO₃ Standard Solution B.

23.3 Select the standard with the lowest sulfur concentration and make several determinations as directed in 24.1 or 24.2 until the system is stabilized as shown by reproducible titrations.

23.4 Continue with multiple portions of each additional standard, as directed in 24.1 or 24.2, running the standards in ascending order of sulfur concentration.

23.5 Prepare a calibration curve by plotting the percentage of sulfur in each standard against the average of the millilitres of KIO₃ Standard Solution (or apparent percentage of sulfur for “direct-reading” burets). Prepare a separate calibration curve for each sample weight/sulfur range (24.1.3).

23.6 Repeat the calibration: (1) when another KIO₃ Standard Solution or another starch-iodide solution is ~~used~~,used; (2) when a different lot of boats (or crucibles) is ~~used~~,used; (3) when a different lot of accelerator is ~~used~~,used; (4) when a different cylinder of oxygen is ~~used~~,used; (5) when the system has not been in use for 1 h, or less than 1 h if the oxygen flow rate has not been maintained during that ~~period~~,period; (6) when the system has been in use continuously for ~~8 h~~,8 h; (7) when the operating temperature has been ~~changed~~,changed; and (8) when a change in sample weight as indicated in 24.1.3 is required.

24. Procedure

24.1 Combustion with Resistance Furnace:

24.1.1 Adjust the temperature of the furnace to 1400 °C to 1425 °C.

24.1.2 Add 65 mL to 70 mL of HCl (1 + 99) and 2 mL of starch-iodide solution to the absorption vessel. Pass oxygen through the system at a constant rate which is the maximum compatible with the particular absorption system used but not less than 1.0 L/min and not more than 1.5 L/min. Add KIO₃ Standard Solution from the buret until the intensity of the blue color is that which is to be taken as the end point of the final titration. Read the buret and record as the initial reading, and refill the buret. Turn off the oxygen.

24.1.3 Select and weigh a sample in accordance with the following:

Sulfur, %	Sample Weight, g	Tolerance in Sample Weight, mg
0.005 to 0.10	1.000	1.0
0.10 to 0.25	0.500	0.5
0.25 to 0.60	0.250	0.5

Transfer the sample to a preignited combustion boat and spread it in a layer of uniform thickness.

24.1.4 Cover the sample with 0.5 g of iron accelerator and approximately 0.25 g of copper accelerator. Place a preignited cover on the boat and introduce it into the center of the combustion zone. Close the tube and allow the sample to heat for 1.5 min. Start the flow of oxygen at the rate used in 24.1.2.

24.1.5 Titrate the evolved SO₂ continuously with the appropriate KIO₃ Standard Solution at such a rate as to maintain as nearly as possible the initial intensity of the blue color. Continue the flow of oxygen for 10 min, record the buret reading, and subtract the initial reading obtained in 24.1.2. Drain the absorption vessel. If the net volume differs by more than a factor of three from that required for the sample previously analyzed, disregard the result and repeat the analysis a sufficient number of times to stabilize the system before proceeding as directed in 23.1.

24.2 Combustion with Induction Furnace :

24.2.1 Turn on the power of the induction furnace and allow the electronic circuit to heat to operating temperature. Depress the starting button until the ammeter indicates that the current is flowing through the induction coil.

24.2.2 Proceed as directed in 24.1.2.

24.2.3 Proceed as directed in 24.1.3 substituting a crucible for the combustion boat.

24.2.4 Add 0.5 g of iron accelerator, 1.0 g of tin, and approximately 0.5 g of copper accelerator. Place a preignited cover on the crucible and introduce it into the center of the combustion zone. Close the tube, start the flow of oxygen at the rate used in 24.2.2, turn on the power, and increase it to the maximum at such a rate that spattering of the molten sample is avoided.

24.2.5 Proceed as directed in 24.1.5, but discontinue the flow of oxygen after 4 to 5 min or when the titration is complete. Turn off the power to the induction coil.

25. Calculation

25.1 Read the percentage of sulfur in the sample from the appropriate curve plotted as directed in 23.5.

26. Precision and Bias

26.1 Although samples covered by this test method with appropriate sulfur concentrations for evaluation of the test method were not available, the precision data summarized in 45.1 of Test Methods E 353 should apply.

26.2 Twenty-two laboratories cooperated in testing this test method; six used resistance furnaces and reported eight sets of values (Note 5); sixteen used induction furnaces (Note 6). They obtained the data summarized in Table 23 for Material 7. Although

samples covered by this test method with sulfur concentration near the lower limit of the scope were not available for testing, the precision data obtained using the test methods indicated in Table 23 should apply. None was available to permit a test near the upper limit of the scope.

NOTE 5—The recovery of sulfur as SO₂ ranged from 72 % to 97 % with an average value of 83 % based on calibration standards designated *b*, *c*, and *d* in Table 3Table 4.

NOTE 6—The recovery of sulfur as SO₂ ranged from 80 % to 96 % with an average value of 88 % based on calibration standards designated *b*, *c*, and *d* in Table 3Table 4.

26.3 *Bias*—No information on the accuracy of this test method is known. The accuracy of this test method may be judged by comparing accepted reference values with the corresponding arithmetic average obtained by interlaboratory testing.

SILICON BY THE GRAVIMETRIC METHOD

27. Scope

27.1 This test method covers the determination of silicon in concentrations from 0.05 % to 5.00 % in alloys containing not more than 0.1 % boron.

28. Summary of Test Method

28.1 After dissolution of the sample, silicic acid is dehydrated by fuming with sulfuric or perchloric acid. The solution is filtered, and the impure silica is ignited and weighted. The silica is then volatilized with hydrofluoric acid. The residue is ignited and weighed; the loss in weight represents silica.

29. Interferences

29.1 The elements normally present do not interfere. When boron is present in amounts greater than 0.1 %, the sample solution requires special treatment with methyl alcohol. (**Warning—See Warning—See Practices E 50.**) prior to acid dehydration. However, since no boron steels were tested, this special treatment was not evaluated.

30. Reagents

30.1 The analyst should make certain by analyzing blanks and other checks that possible silicon contamination of reagents will not significantly bias the results.

30.2 Perchloric Acid:

30.2.1 Select a lot of HClO₄ that contains not more than 0.0002 % silicon for the analysis of samples containing silicon in the range from 0.02 % to 0.10 % and not more than 0.0004 % silicon for samples containing more than 0.10 % by determining duplicate values for silicon as directed in 30.2.2 through 30.2.7.

30.2.2 Transfer 15 mL of HClO₄ through 30.2.6.

30.2.2 Transfer 15 mL of HClO₄ (Note 7) to each of two 400-mL beakers. To one of the beakers transfer an additional 50 mL of HClO₄. Using a pipet, transfer 20 mL of Na₂SiO₃ solution (1 mL = 1.00 mg Si) to each of the beakers. Evaporate the solutions to fumes and heat for 15 to 20 min at such a rate that HClO₄ refluxes on the sides of the beakers. Cool sufficiently, and add 100 mL of water (40 °C to 50 °C).

NOTE 7—The 15-mL addition of HClO₄ came from the same lot as the one to be tested. Once a lot has been established as having less than 0.0002 % silicon, it should preferably be used for the 15-mL addition in all subsequent tests of other lots of acid.

30.2.3 Add paper pulp and filter immediately, using low-ash 11-cm medium-porosity filter papers. Transfer the precipitates to the papers, and scrub the beakers thoroughly with a rubber-tipped rod. Wash the papers and precipitates alternately with 3-mL to 5-mL portions of hot HCl (1 + 19) and hot water, for a total of 6six times. Finally wash the papers twice with H₂SO₄ (1 + 49). Transfer the papers to platinum crucibles.

30.2.4 Dry the papers and heat at 600 °C until the carbon is removed. Finally ignite at 1100 °C to 1150 °C or to constant weight (at least 30 min). Cool in a desiccator and weigh.

TABLE 3 4 Statistical Information—Silicon

Test Specimen	Silicon Found, %	Repeatability (<i>R</i> ₁ , Practice E 173)	Reproducibility (<i>R</i> ₂ , Practice E 173)
HClO ₄ Dehydration			
1. Ni-base alloy 75Ni-12Cr-6Al-4Mo-2Cb-0.7Ti	0.029	0.006	0.026
H ₂ SO ₄ Dehydration			
1. Ni-base alloy 75Ni-12Cr-6Al-4Mo-2Cb-0.7Ti	0.030	0.007	0.030
2. Co-base alloy 66Co-28Cr-4W-1.5Ni	1.01	0.03	0.06

30.2.5 Add enough H₂SO₄ (1 + 1) to moisten the SiO₂, and add 3 mL to 5 mL of HF. Evaporate to dryness and then heat at a gradually increasing rate until H₂SO₄ is removed. Ignite for 15 min at 1100 °C to 1150 °C, cool in a desiccator, and weigh.

30.2.6 Calculate the percentage of silicon as follows:

$$\text{Silicon, \%} = [(A - B) - (C - D)] \times 0.4674/E \times 100 \quad (2)$$

where:

A = initial weight of crucible plus impure SiO₂ when 65 mL of HClO₄ was taken, g,

B = final weight of crucible plus impurities when 65 mL of HClO₄ was taken, g,

C = final weight of crucible plus impurities when 15 mL of HClO₄ was taken, g,

D = final weight of crucible plus impurities when 15 mL of HClO₄ was taken, g, and

E = nominal weight (80 g) of 50 mL of HClO₄.

30.3 *Sodium Silicate Solution (1.00 mg/mL Si)*—Transfer 11.0 g of sodium silicate (Na₂SiO₃·9H₂O) to a 400-mL beaker. Add 150 mL of water and dissolve the salt. Filter through a medium paper, collecting the filtrate in a 1-L volumetric flask, dilute to volume, and mix. Store in a polyethylene bottle. Use this solution to determine the suitability of the HClO₄.

30.4 *Tartaric Acid Solution (20.6 g/L)*—Dissolve 20.6 g of tartaric acid (C₄H₆O₆) in water, dilute to 1 L, and filter.

30.5 *Water*—Use freshly prepared Type II water known to be free of silicon. Water distilled from glass, demineralized in columns containing silicon compounds, or stored for extended periods in glass, or combination thereof, has been known to pick up silicon.

31. Procedure

31.1 Select and weigh a sample in accordance with the following:

Silicon, %	Sample Weight, g	Tolerance in Sample Weight, mg	Dehydrating Acid, mL	
			H ₂ SO ₄ (1+4)	HClO ₄
0.05 to 0.10	5.0	5	150	75
0.10 to 1.0	4.0	4	100	60
1.0 to 2.0	3.0	3	100	50
2.0 to 5.0	2.0	2	100	40

Transfer it to a 400-mL beaker or a 300-mL porcelain casserole. Proceed as directed in 31.2 or 31.3.

31.2 Proceed as directed in 31.4 if tungsten is greater than 0.5 %.

31.3 Proceed as directed in 31.2 or 31.5 if tungsten is less than 0.5 %.

31.4 *Sulfuric Acid Dehydration:*

31.4.1 Add amounts of HCl or HNO₃, or mixtures and dilutions of these acids, that are sufficient to dissolve the sample; and then add the H₂SO₄ (1 + 4) as specified in 30.1, and cover. Heat until dissolution is complete. Remove and rinse the cover glass; substitute a ribbed cover glass.

31.4.2 Evaporate until salts begin to separate; at this point evaporate the solution rapidly to the first appearance of fumes and fume strongly for 2 to 3 min. Cool sufficiently, and add 100 mL of water (40 °C to 50 °C). Stir to dissolve the salts and heat, if necessary, but do not boil. Proceed immediately as directed in 31.6.

31.5 *Perchloric Acid Dehydration :*

31.5.1 Add amounts of HCl or HNO₃, or mixtures and dilutions of these acids, which are sufficient to dissolve the sample, and cover. Heat until dissolution is complete. Add HNO₃ to provide a total of 35 mL to 40 mL, followed by HClO₄ as specified in the table in 31.1. Remove and rinse the cover glass; substitute a ribbed cover glass.

31.5.2 Evaporate the solution to fumes and heat for 15 to 20 min at such a rate that the HClO₄ refluxes on the sides of the container. Cool sufficiently and add 100 mL of water (40 °C to 50 °C). Stir to dissolve the salts and heat to boiling. If the sample solution contains more than 100 mg of chromium, add, while stirring, 1 mL of tartaric acid solution for each 25 mg of chromium.

31.6 Add paper pulp and filter immediately, on a low-ash 11-cm medium-porosity filter paper. Collect the filtrate in a 600-mL beaker. Transfer the precipitate to the paper, and scrub the container thoroughly with a rubber-tipped rod. Wash the paper and precipitate alternately with 3-mL to 5-mL portions of hot HCl (1 + 19) and hot water until iron salts are removed but for not more than a total of ten washings. If 31.3 was followed, wash the paper twice more with H₂SO₄ (1 + 49), but do not collect these washings in the filtrate; discard the washings. Transfer the paper to a platinum crucible and reserve.

31.7 Add 15 mL of HNO₃ to the filtrate, stir, and evaporate as directed either in 31.2 or 31.3, depending upon the dehydrating acid used. Filter immediately, using a low-ash 9-cm 100-porosity filter paper, and wash as directed in 31.6.

31.8 Transfer the paper and precipitate to the reserved platinum crucible. Dry the papers and then heat the crucible at 600 °C until the carbon is removed. Finally ignite at 1100 °C to 1150 °C to constant weight (at least 30 min). Cool in a desiccator and weigh.

31.9 Add enough H₂SO₄(1+1) to moisten the impure SiO₂ (1 + 1) to moisten the impure silica (SiO₂), and add 3 mL to 5 mL of HF. Evaporate to dryness and then heat at a gradually increasing rate until H₂SO₄ is removed. Ignite at 1100 °C to 1150 °C for 15 min, if the sample contains more than 0.5 % tungsten, ignite at 750 °C instead of 1100 °C to 1150 °C after volatilization of SiO₂, cool in a desiccator, and weigh.

32. Calculation

32.1 Calculate the percent of silicon as follows:

Silicon

$$\text{Silicon, \%} = [(A - B) \times 0.4674]/C \times 100 \quad (3)$$

where:

A = initial weight of crucible and impure SiO₂, g,

B = final weight of crucible and residue, g, and

C = sample used, g.

33. Precision and Bias

33.1 Eleven laboratories cooperated in testing this test method and obtained the data summarized in ~~Table 3~~ Table 4. A sample with silicon concentration near the upper limit of the scope was not available for testing.

33.2 *Bias*—No information on the bias of this test method is known. The bias of this test method may be judged by comparing accepted reference values with the corresponding arithmetic average obtained by interlaboratory testing.

COBALT BY THE ION-EXCHANGE-POTENTIOMETRIC TITRATION METHOD

34. Scope

34.1 This test method covers the determination of cobalt in concentrations from 2 % to 75 %.

35. Summary of Test Method

35.1 Cobalt is separated from interfering elements by selective elution from an anion-exchange column using hydrochloric acid. The cobalt is oxidized to the trivalent state with ferricyanide, and the excess ferricyanide is titrated potentiometrically with cobalt solution.

36. Interferences

36.1 The elements ordinarily present do not interfere if their concentrations are under the maximum limits shown in 1.1.

37. Apparatus

37.1 *Ion-Exchange Column*, approximately 25 mm in diameter and 300 mm long, tapered at one end, and provided with a stopcock to control the flow rate, and a second, lower stopcock to stop the flow. A reservoir for the eluants may be added at the top of the column.

37.2 *Apparatus for Potentiometric Titrations*—Instruments for detecting the end points in pH (acid-base), oxidation-reduction, precipitation, and complexation titrations consist of a pair of suitable electrodes, a potentiometer, a buret, and a motor-driven stirrer. Titrations are based on the fact that when two dissimilar electrodes are placed in a solution there is a potential difference between them. This potential difference depends on the composition of the solution and changes as the titrant is added. A high-impedance electronic voltmeter follows the changes accurately. The end point of the titration may be determined by adding the titrant until the potential difference attains a predetermined value or by plotting the potential difference versus the titrant volume, the titrant being added until the end point has been passed.

37.2.1 An elaborate or highly sensitive and accurate potentiometer is not necessary for potentiometric titrations because the absolute cell voltage needs to be known only approximately, and variations of less than 1 MV are not significant. Such instruments should have a range of about 1.5 V and a readability of about 1 MV. Many of the pH meters satisfying the requirements for Apparatus No. 3A are also suitable for potentiometric titrations.

37.2.2 The electrode system must consist of a reference electrode and an indicator electrode. The reference electrode maintains a constant, but not necessarily a known or reproducible potential during the titration. The potential of the indicator electrode does change during the titration; further, the indicator electrode must be one that will quickly come to equilibrium. In this procedure a platinum indicator electrode and a saturated calomel reference electrode are appropriate.

37.3 *Apparatus No. 3B*, with a platinum and a saturated calomel electrode.

38. Reagents

38.1 *Ammonium Citrate Solution (200 g/L)*—Dissolve 200 g of di-ammonium hydrogen citrate in water and dilute to 1 L.

38.2 *Cobalt, Standard Solution (1 mL = 1.5 mg of Co)*—Reagent No. 25B in Practices E 50.

Preparation—Dry a weighing bottle in an oven at 130 °C for 1 h, cool in a desiccator, and weigh. Transfer 3.945 g of cobalt sulfate (CoSO₄)⁶ that has been heated at 550 °C for 1 h to the weighing bottle. Dry the bottle and contents at 130 °C for 1 h, cool

⁶ Cobalt sulfate (99.9 % minimum) prepared from the hexamine salt by G. Frederick Smith Chemical Co., Columbus, OH, is satisfactory for this purpose.

in desiccator, stopper the bottle, and weigh. The difference in weight is the amount of CoSO_4 taken. Transfer the weighed CoSO_4 to a 400-mL beaker, rinse the weighing bottle with water, and transfer the rinsings to the beaker. Add 150 mL of water and 20 mL of HNO_3 , and heat to dissolve the salts. Cool, transfer to a 1-L volumetric flask, dilute to volume, and mix.

Standardization—Calculate the cobalt concentration as follows:

$$\text{Cobalt, mg/mL} = \text{weight of CoSO}_4, \text{ g} \times 0.38026$$

38.3 Ion-Exchange Resin:⁷

38.3.1 Use an anion exchange resin of the alkyl quaternary ammonium type (chloride form) consisting of spherical beads having a nominal crosslinkage of 8 %, and 200 to 400 nominal mesh size. To remove those beads greater than about 180 μm in diameter as well as the excessively fine beads, treat the resin as follows: Transfer a supply of the resin to a beaker, cover with water, and allow sufficient time (at least 30 min) for the beads to undergo maximum swelling. Place a No. 80 (180- μm) screen, 150 mm in diameter over a 2-L beaker. Prepare a thin slurry of the resin and pour it onto the screen. Wash the fine beads through the screen, using a small stream of water. Discard the beads retained on the screen, periodically, if necessary, to avoid undue clogging of the openings. When the bulk of the collected resin has settled, decant the water and transfer approximately 100 mL of resin to a 400-mL beaker. Add 200 mL of HCl (1 + 19), stir vigorously, allow the resin to settle for 4 to 6 min, decant 150 mL to 175 mL of the suspension, and discard. Repeat the treatment with HCl (1 + 19) twice more, and reserve the coarser resin for the column preparation.

38.3.2 Prepare the column as follows: Place a 10-mm to 20-mm layer of glass wool or poly(vinyl chloride) plastic fiber in the bottom of the column, and add a sufficient amount of the prepared resin to fill the column to a height of approximately 140 mm. Place a 20-mm layer of glass wool or poly(vinyl chloride) plastic fiber at the top of the resin bed to protect it from being carried into suspension when the solutions are added. While passing a minimum of 35 mL of HCl (7 + 5) through the column, with the hydrostatic head 100 mm above the top of the resin bed, adjust the flow rate to not more than 3.0 mL/min. Drain to 10 mm to 20 mm above the top of the resin bed and then close the lower stopcock.

NOTE 8—The maximum limits of 0.125 g of cobalt and 0.500 g in the sample take into account the exchange capacity of the resin, the physical dimensions of the column, and the volume of eluants.

38.4 *Potassium Ferricyanide, Standard Solution* (1 mL = 3.0 mg of Co):

38.4.1 Dissolve 16.68 g of potassium ferricyanide ($\text{K}_3\text{Fe}(\text{CN})_6$) in water and dilute to 1 L. Store the solution in a dark-colored bottle. Standardize the solution each day before use as follows: Transfer from a 50-mL buret approximately 20 mL of $\text{K}_3\text{Fe}(\text{CN})_6$ solution to a 400-mL beaker. Record the buret reading to the nearest 0.01 mL. Add 25 mL of water, 10 mL of ammonium citrate solution, and 25 mL of NH_4OH . Cool to 5 $^\circ\text{C}$ to 10 $^\circ\text{C}$, and maintain this temperature during the titration. Transfer the beaker to the potentiometric titration apparatus. While stirring, titrate the $\text{K}_3\text{Fe}(\text{CN})_6$ with the cobalt solution (1 mL = 1.5 mg Co) using a 50-mL buret. Titrate at a fairly rapid rate until the end point is approached, and then add the titrant in ~~1-drop-one-drop~~ increments through the end point. After the addition of each increment, record the buret reading and voltage when equilibrium is reached. Estimate the buret reading at the end point to the nearest 0.01 mL by interpolation.

38.4.2 Calculate the cobalt equivalent as follows (Note 9): $\text{Cobalt equivalent, mg/m}$

$$\text{Cobalt equivalent, mg/mL} = (A \times B)/C \quad (4)$$

where:

- A = cobalt standard solution required to titrate the potassium ferricyanide solution, mL,
- B = cobalt standard solution, mg/mL, and
- C = potassium ferricyanide solution, mL.

NOTE 9—Duplicate or triplicate values should be obtained for the cobalt equivalent. The values obtained should check within 1 to 2 parts per thousand.

39. Procedure

39.1 Transfer 0.50-g samples for cobalt concentrations not greater than 25 %; at higher concentrations use samples that represent between 100 mg and 125 mg of cobalt and weighed to the nearest 0.1 mg. Transfer all of the sample to a 150-mL beaker. Add 20 mL of a mixture of five parts of HCl and one part of HNO_3 (Note 10). Cover the beaker and digest at 60 $^\circ\text{C}$ to 70 $^\circ\text{C}$ until the sample is decomposed. Rinse and remove the cover. Place a ribbed cover glass on the beaker and evaporate the solution nearly to dryness, but do not bake. Cool, add 20 mL of HCl (7 + 5), and digest at 60 $^\circ\text{C}$ to 70 $^\circ\text{C}$ until salts are dissolved (approximately 10 min).

NOTE 10—Other ratios and concentrations of acids, with or without the addition of 1 mL to 2 mL of HF, are used for the decomposition of special grades of alloys.

Some alloys are decomposed more readily by a mixture of 5 mL of bromine, 15 mL of HCl, and one to two drops of HF.

39.2 Cool to room temperature and transfer the solution to the ion-exchange column. Place a beaker under the column and open the lower stopcock. When the solution reaches a level 10 mm to 20 mm above the resin bed, rinse the original beaker with 5 mL

⁷ Available from the Dow Chemical Co., Midland, MI.

to 6 mL of HCl (7 + 5) and transfer the rinsings to the column. Repeat this at 2-min intervals until the beaker has been rinsed four times. Wash the upper part of the column with HCl (7 + 5) ~~two~~ two or ~~three~~ three times and allow the level to drop to 10 mm to 20 mm above the resin bed each time. Maintain the flow rate at not more than 3.0 mL/min and add HCl (7 + 5) to the column until a total of 175 mL to 185 mL of solution (sample solution and washings) containing mainly chromium, manganese, and nickel is collected (Note 11). When the solution in the column reaches a level 10 mm to 20 mm above the resin bed, discard the eluate and then use a 400-mL beaker for the collection of the cobalt eluate.

NOTE 11—To prevent any loss of cobalt, the leading edge of the cobalt band must not be allowed to proceed any farther than 25 mm from the bottom of the resin. Normally, when the cobalt has reached this point in the column, the chromium, manganese, and nickel have been removed. Elution can be stopped at this point, although the total volume collected may be less than 175 mL.

39.3 Add HCl (1 + 2) to the column and collect 165 mL to 175 mL of the solution while maintaining the 3.0-mL/min flow rate. Reserve the solution. If the sample solution did not contain more than 0.200 g of iron, substitute a 250-mL beaker and precondition the column for the next sample as follows: Drain the remaining solution in the column to 10 mm to 20 mm above the resin bed, pass 35 mL to 50 mL of HCl (7 + 5) through the column until 10 mm to 20 mm of the solution remains above the resin bed, then close the lower stopcock. If the sample solution contained more than 0.200 g of iron, or if the column is not to be used again within 3 h, discard the resin and recharge the column as directed in 38.3.

39.4 Add 30 mL of HNO₃ and 15 mL of HClO₄ to the solution from 39.3 and evaporate to fumes of HClO₄. Cool, add 25 mL to 35 mL of water, boil for 1 to 2 min, cool, and add 10 mL of ammonium citrate solution.

39.5 Using a 50-mL buret, transfer to a 400-mL beaker a sufficient volume of K₃Fe(CN)₆ solution to oxidize the cobalt and to provide an excess of about 5 mL to 8 mL. Record the buret reading to the nearest 0.01 mL. Add 50 mL of NH₄OH and cool to 5 °C to 10 °C. Transfer the beaker to the potentiometric titration apparatus and maintain the 5 °C to 10 °C temperature during the titration.

39.6 While stirring, add the sample solution to the solution from 39.5, rinse the beaker with water, and add the rinsings to the solution (Note 12). Using a 50-mL buret, titrate the excess K₃Fe(CN)₆ with the cobalt solution (1 mL = 1.5 mg Co), at a fairly rapid rate until the end point is approached, and then add the titrant in ~~1-drop~~ one-drop increments through the end point. After the addition of each increment, record the buret reading and voltage when equilibrium is reached. Estimate the buret reading at the end point to the nearest 0.01 mL by interpolation.

NOTE 12—For a successful titration, the sample solution must be added to the excess K₃Fe(CN)₆ solution.

40. Calculation

40.1 Calculate the percent of cobalt as follows: Cobalt

$$\text{Cobalt, \%} = [(AB - CD)/E] \times 100 \quad (5)$$

where:

A = standard potassium ferricyanide solution, mL,

B = cobalt equivalent of the standard potassium ferricyanide solution,

C = cobalt standard solution, mL,

D = concentration of cobalt standard solution, mg/mL, and

E = sample used, mg.

41. Precision and Bias

41.1 Ten laboratories cooperated in testing this test method and obtained the data summarized in ~~Table 4~~ Table 5 for Specimens 4 through 8. Although samples covered by this test method with cobalt concentrations near the lower limit of the scope were not available for testing, the precision data obtained for Specimens 1, 2, and 3 using the test method indicated in ~~Table 4~~ Table 5 should apply.

41.2 *Bias*—No information on the accuracy of this test method is known. The accuracy of this test method may be judged by comparing accepted reference values with the corresponding arithmetic average obtained by interlaboratory testing.

COBALT BY THE NITROSO-R-SALT PHOTOMETRIC METHOD

42. Scope

42.1 This test method covers the determination of cobalt in concentrations from 0.10 % to 5.0 %.

43. Summary of Test Method

43.1 The sample solution is treated with zinc oxide to remove iron, chromium, and vanadium. Nitroso-R-salt solution is added to a portion of the filtrate which has been buffered with sodium acetate to produce an orange-colored complex with cobalt. The addition of nitric acid stabilizes the cobalt complex and also destroys certain interfering complexes. Photometric measurement is made at approximately 520 nm.

44. Concentration Range

44.1 The recommended concentration range is from 0.005 mg to 0.15 mg of cobalt per 50 mL of solution, using a 1-cm cell.