



Designation: ~~C952-91 (Reapproved 1997)~~^{ε1} Designation: **C 952 - 02 (Reapproved 2009)**

Standard Test Method for Bond Strength of Mortar to Masonry Units¹

This standard is issued under the fixed designation C 952; the number immediately following the designation indicates the year of original adoption or, in the case of revision, the year of last revision. A number in parentheses indicates the year of last reapproval. A superscript epsilon (ϵ) indicates an editorial change since the last revision or reapproval.

This standard has been approved for use by agencies of the Department of Defense.

^{ε1}Note—Section 13 on Keywords was added editorially in November 1997.

1. Scope

~~1.1 This test method provides two procedures for measuring bond strength of mortar to masonry units: a crossed brick couplet tensile test for evaluating mortar-brick bonding and a stacked-bond, flexural test for evaluating mortar-concrete block bonding.~~

~~1.2~~

1.1 This test method provides two procedures for measuring bond strength of mortar to masonry units: a crossed brick couplet tensile test for evaluating mortar-brick bond strength and a stacked-bond, flexural test for evaluating mortar-concrete block bond strength.

1.2 The values stated in inch-pound units are to be regarded as standard. The values given in parentheses are mathematical conversions to SI units that are provided for information only and are not considered standard.

1.3 This standard does not purport to address the safety concerns, if any, associated with its use. It is the responsibility of the user of this standard to establish appropriate safety and health practices and determine the applicability of regulatory limitations prior to use.

2. Referenced Documents

2.1 *ASTM Standards:*²

~~C 67 Test Methods for Sampling and Testing Brick and Structural Clay Tile~~

~~C 91 Specification for Masonry Cement~~

~~90 Specification for Loadbearing Concrete Masonry Units~~

~~C 109 Test Method for Compressive Strength of Hydraulic Cement Mortars (Using 2-in. or 50-mm Cube Specimens)~~³

~~129 Specification for Nonloadbearing Concrete Masonry Units~~

~~C 190 Test Method for Tensile Strength of Hydraulic Cement Mortars~~³

~~C 230 Specification for Flow Table for Use in Tests of Hydraulic Cement~~³ 140 Test Methods for Sampling and Testing Concrete Masonry Units and Related Units

~~C 270 Specification for Mortar for Unit Masonry~~

~~C 305 Practice for Mechanical Mixing of Hydraulic Cement Pastes and Mortars of Plastic Consistency~~³

~~780 Test Method for Preconstruction and Construction Evaluation of Mortars for Plain and Reinforced Unit Masonry~~

~~C 427 Test Method for Moisture Condition of Hardened Concrete by the Relative Humidity Method~~ 1072 Test Method for Measurement of Masonry Flexural Bond Strength

~~C 1357 Test Methods for Evaluating Masonry Bond Strength~~

~~C 1437 Test Method for Flow of Hydraulic Cement Mortar~~

~~E 518 Test Methods for Flexural Bond Strength of Masonry~~

3. Significance and Use

~~3.1 These procedures are useful for research into bonding of masonry. They are not intended to predict the bond strength of commercial masonry construction. The bonding in commercially built structures is determined by many factors beyond the characteristics of mortar, masonry units, and the procedures of this test method.~~

3.1 These procedures are useful for research into bond strength of masonry. They are not intended to predict the bond strength

¹ This test method is under the jurisdiction of ASTM Committee C15 on Manufactured Masonry Units and is the direct responsibility of Subcommittee C15.04 on Research. Committee E-6 maintains a continued interest in these practices and will make use of them in the future.

Current edition approved April 15, 1991. Published June 1991. Originally published as E149-59T. Redesignated C952-76 in 1981. Last previous edition C952-86.

Current edition approved June 1, 2009. Published July 2009. Originally approved in 1959. Last previous edition approved in 2002 as C 952 - 02^{ε1}.

² For referenced ASTM standards, visit the ASTM website, www.astm.org, or contact ASTM Customer Service at service@astm.org. For *Annual Book of ASTM Standards* Volume information, refer to the standard's Document Summary page on the ASTM website.

of commercial masonry construction. The bond strength in commercially built structures is determined by many factors beyond the characteristics of mortar, masonry units, and the procedures of this test method.

NOTE 1—The crossed-brick couplets method measures a direct tensile strength of the bond between the mortar and masonry unit. It does not determine the flexural strength of the unit mortar assembly. Other test methods may be more appropriate for determining the flexural bond strength between mortar and masonry units. These include Test Method C 1072, Test Methods C 1357, and Test Methods E 518.

PREPARATION AND TESTING OF FRESH MORTAR

4. Preparation of Mortar

4.1 Apparatus:

4.1.1 *Scales, Weights, and Glass Graduates* conforming to 2.1, 2.2, and 2.4 of Test Method C190 except that the scales and scale weights shall be of suitable capacity.

4.1.2 *Mixer, Paddle, Mixing Bowl, and Scraper* conforming to 2.1 to 2.4, of Method C305 except that the mixer, paddle, and mixing bowl shall have a capacity of 10 qt (0.01 m³) and the first or slow speed of the mixer shall revolve the paddle at a rate of 144 ± 5 rpm, with a planetary speed of approximately 61 rpm. The second speed shall revolve the paddle at a rate of 258 ± 10 rpm, with a planetary motion of approximately 109 rpm.

4.1.3 Stop Clock:

4.2 Procedure:

4.2.1 Weigh or measure the proper quantities of aggregates (Note 1), cementing materials, and water needed for the batch. The amount of water used shall provide a mortar of wet consistency, and the mortar shall preferably be as wet as can conveniently be handled with a mason's trowel.

4.1 Proportion mortar materials by weights equivalent to volume proportions to be used in prism construction. Use unit weights for individual materials as given in Specification C 270. Sand shall be permitted to be used in a damp loose condition, provided that moisture content of sand is determined with reference to the oven-dried condition and batch proportions are adjusted accordingly. Record weight of ingredients (including water) added to the batch of mortar.

4.2 Mix mortar in a mechanical paddle-type mortar mixer. Time periods referenced below are measured from when water and cementitious materials are combined.

4.2.1 Add an estimated amount of water to the mortar to achieve the desired consistency (Note 2). Mix mortar for three minutes and determine consistency. If the desired consistency is specified by flow determine it in accordance with Test Method C 1437. If the desired consistency is specified as initial cone penetration, determine it in accordance with Test Method C 780. Once consistency is recorded, return the material used to measure the consistency to the mixer. If the consistency is within the desired range, continue mixing the batch for an additional two minutes. If the consistency is less than the desired range, add water to the batch and mix for one minute and determine consistency. Once consistency is recorded, return the material used to measure consistency to the mixer. If the consistency is within the desired range, continue mixing the batch for one minute.

NOTE 1—About 400 g of aggregate will provide sufficient mortar for several bond test specimens.

4.2.2 Charge the mixing bowl with the measured amounts of aggregate and cementing material. Mix manually with a spoon for 5 s. Insert the paddle into the mixture. Preset the stop clock to 10 s before zero time. Set the mixer at No. 1 (slow) speed, approximately 144 rpm.

4.2.3 Simultaneously start the stop clock and the mixer. Mix for 10 s.

4.2.4 At zero time and at a continuing slow speed, add the major portion (approximately 95%) of the mixing water within 10 s. Continue mixing for an additional 10 s.

4.2.5 Stop the mixer. Change quickly to No. 2 (fast) speed (about 260 rpm) and resume mixing. Continue mixing for a total of 2-min elapsed time starting from zero time.

4.2.6 Stop the mixer. Let the mortar stand in the bowl for 10 min with the bowl covered with a slotted lid, permitting the paddle to remain in the mortar. Before placement of the lid within the first 15 s of the 10-min waiting period, quickly scrape down into the batch with a rubber scraper any mortar that may have collected on the side of the bowl.

NOTE 2—If the mortar is one that tends to segregate and in which the fines stick to the bottom of the bowl, the paddle may be temporarily removed and the scraper applied to the extreme bottom of the bowl to bring up such fines as may have adhered to the bowl bottom.

4.2.7 Remove the cover, change to No. 1 (slow) speed, and mix for 30 s. Add the remainder of the mixing water during the first part of this 30-s interval. Stop the mixer, change promptly to No. 2 (fast) speed, and finish by mixing for an additional 30 s.

5. Initial Flow of Mortar

5.1 *Apparatus*—The flow table and flow mold shall conform to the requirements of Specification C230.

5.2 *Procedure*—Immediately after final mixing of the mortar, determine the initial flow of mortar from the bowl in accordance with 8.3 of Test Method C109 excepting the reference to trial mortars at the end of that section. Discard that portion of the mortar used to determine the initial flow.

NOTE 3—The high flow of some mortars makes it advisable to drop the table less than 25 drops before measuring the flow. When calculating the initial

flow for 25 drops of such mortars, the measured flow should be increased by adding two percentage points of flow for each drop of the table less than 25.

6. Water Retention of Mortar

6.1 *Apparatus*—Water retention apparatus shall conform to the requirements for the apparatus in Section 25 of Specification C91.

6.2 *Procedure*—Immediately after measuring the initial flow, remix the mortar remaining in the bowl for 15 s; then determine the flow after suction and the water retention of the mortar in accordance with the requirements of Sections 28 and 29 of Specification C91.

Note 4—The number of drops of the flow table shall be the same as that used to determine the initial flow and, excepting that the mortar is not necessarily tempered to an initial flow of 110% and that the mortar used for determining the initial flow is discarded and not returned to mixing bowl, the procedure shall be in accordance with the specified requirements.

7. Air Content of Mortar

7.1 *Apparatus*—Measure, straightedge, spatula, and other needed apparatus conforming to 18.1 of Specification C91.

7.2 *Procedure*:

7.2.1 *Preliminary*—Place the mortar remaining in the mixing bowl after filling the suction cup for water retention test on a mortar board and use for the fabrication of bond test specimens. After mortar for bond test specimens has been taken from the board, determine the air content of the mortar remaining on the board.

7.2.2 *Final*—Determine the weight of 400 mL of mortar as specified in 20.1 of Specification C91, except that the mortar is not necessarily tempered to an initial flow of 110%.

7.3 *Calculation*—Calculate the air content of the mortar in accordance with Section 22 of Specification C91, except that the specific gravity of the sand (value S_2 in the equation) shall be that of the sand used in the mortar.

8. Compressive Strength of Mortar

8.1 *Apparatus*—Specimen molds, tamper, trowel, and testing machine conforming to 3.5, 3.8, 3.9, and 3.10 of Test Method C109.

8.2 *Procedure*—Preparation of specimen molds and molding of test specimens shall conform to Sections 7 and 8.4 of Method C109. Fill the molds after determination of the weight of 400 mL of the mortar in accordance with 5.2.2 of this test method.

8.3 *Storage of Test Specimens*—Store mortar cubes in accordance with 11.2.2 of Specification C270. 2—Workable consistency of mortar for concrete masonry construction generally requires an initial cone penetration reading of 55 ± 5 mm or a flow of 125 ± 5 %. Workable consistency of mortar for clay masonry construction generally requires an initial cone penetration reading of 65 ± 5 mm or a flow of 135 ± 5 %. Optimum consistency for a specific mortar-unit combination may differ from these values.

4.2.2 If after the one-time addition of water the consistency is not in the desired range, discard the batch.

4.2.3 If the measured consistency exceeds the desired range at any time, discard the batch.

4.3 Immediately after mixing the mortar, determine its initial cone penetration in accordance with Test Method C 780. Determine the cone penetration of the mortar every 15 ± 5 minutes. If the cone penetration is less than 80 % of its initial value, discard the remaining portion of the mortar without constructing additional mortar joints.

PREPARATION AND TESTING OF BOND STRENGTH TEST SPECIMENS

9.

5. Apparatus

9.1

5.1 *Miscellaneous*— Brass-covered mortar board 18 in. (457 mm) square, an 11-in. (279-mm) long mason’s trowel, laboratory trowel with straight edges, short handled spoon or scoop of ¼-cup (0.5-dm³) capacity, steel straightedge 10 in. (254 mm) long, metal mold ½ in. (13 mm) deep with 3⅝-in. (92-mm) square opening beveled to slope of 0.08 (total 0.04), splash board (Fig. 1)

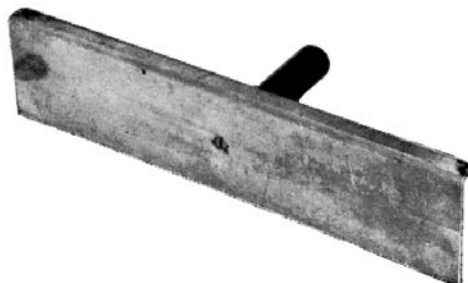

FIG. 1 Splash Board

with handle 20 in. (508 mm) long and 3 in. (76 mm) wide.

9.2

5.2 *Drop Hammer* for crossed-brick couplets (Fig. 2, Table 1).

9.3

5.3 *Drop Hammer* for block assemblies (Fig. 3).

9.4

5.4 *Loading Jigs* for crossed-brick couplets (Fig. 4).

9.5

5.5 *Frames* (Fig. 5) for testing block assemblies: upper frame fitted with ball bearing mounted 10 in. (254 mm) from vertical axis of specimen for eccentric application of vertical load. Fig. 5.

9.6

5.6 *Torque Wrench*.

10.

6. Crossed-Brick Couplets

10.1

6.1 *Brick*—Test specimens consisting of crossed-brick couplets may be used to determine:

10.1.1 Bond between specified brick and a specified mortar;

10.1.2 Relative bond between different brick and a specified mortar, or

10.1.3 Relative bond between a specified brick and different mortars.

10.1.4 In each case, the initial rate of absorption of the brick shall be determined in accordance with Section 29 of Methods C67.

For 10.1.1, the brick used for couplets should include the full range of absorption rates acceptable under the specifications. For 10.1.3, absorption rates of the brick should be limited to a range of 15 g.

10.2

6.1.1 Bond between specified brick and a specified mortar.

6.1.2 Relative bond between different brick and a specified mortar, or

6.1.3 Relative bond between a specified brick and different mortars.

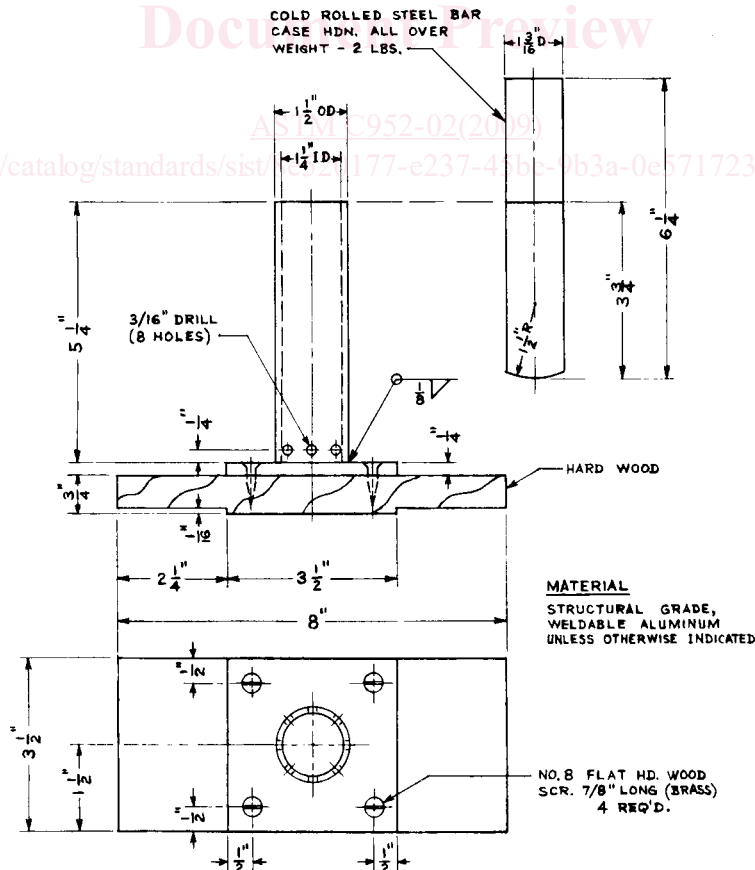

FIG. 2 Drop Hammer for Cross-Brick Couplets

TABLE 1 Metric Equivalents for Figs. 2, 3, 4, 5, and 6

Inch-Pound	Metric	Inch-Pound	Metric	Inch-Pound	Metric
1/16 in.	1.6 mm	1 1/4 in.	44 mm	5 in.	127 mm
1/8 in.	3 mm	1 1/8 in.	48 mm	5 1/4 in.	133 mm
3/16 in.	4.7 mm	2 in.	51 mm	5 3/4 in.	146 mm
1/4 in.	6.4 mm	2 1/8 in.	54 mm	6 in.	152 mm
3/8 in.	9.5 mm	2 1/4 in.	57 mm	6 1/4 in.	159 mm
7/16 in.	11 mm	2 3/8 in.	61 mm	7 1/2 in.	190 mm
1/2 in.	12.7 mm	2 1/2 in.	64 mm	8 in.	203 mm
5/8 in.	15.8 mm	2 5/8 in.	67 mm	8 1/2 in.	216 mm
3/4 in.	19 mm	3 in.	76 mm	9 3/4 in.	248 mm
7/8 in.	22 mm	3 1/8 in.	79 mm	10 3/4 in.	273 mm
1 in.	25 mm	3 1/4 in.	82 mm	16 in.	406 mm
1 1/8 in.	28 mm	3 1/2 in.	89 mm	16 1/2 in.	419 mm
1 1/4 in.	30 mm	3 5/8 in.	92 mm	18 3/4 in.	476 mm
1 1/2 in.	32 mm	3 3/4 in.	95 mm	28 in.	711 mm
1 5/8 in.	35 mm	4 in.	102 mm	2 lb	0.9 kg
1 1/2 in.	38 mm	4 1/4 in.	121 mm	3.5 lb	1.6 kg

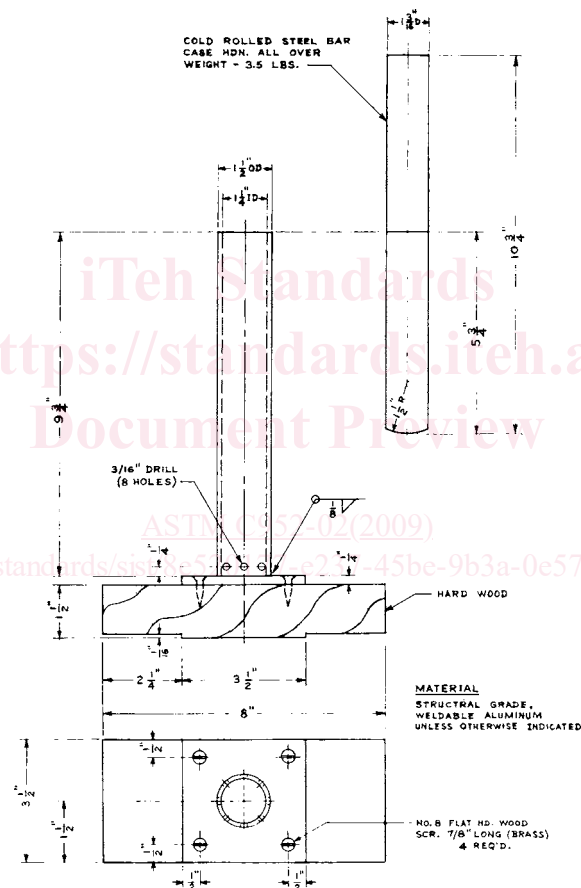

FIG. 3 Drop Hammer for Concrete Block Assemblies

6.1.4 In each case, the initial rate of absorption of the brick shall be determined in accordance with Test Methods C 67. The brick used for couplets shall include the full range of absorption rates acceptable under the specifications.

6.2 Construction of Test Specimens :

10.2.1 Dump 6.2.1 Center the mortar remaining in mixing bowl after removal of the quantity needed for measurement of the initial flow and water retention on the mortar board and note its temperature.

10.2.2 Center the mold on the lower brick of the couplet and lightly mix a small quantity of mortar on the board by turning over with the spoon.

10.2.3 Half-fill 6.2.2 Half-fill the mold by sharply dashing into each corner and the center of the mold a small quantity of mortar from the half-filled spoon. Note the time at start of a 1-min interval. Apply additional mortar by heaping loosely with the spoon above the top of the mold. Strike off excess mortar with the straightedge, starting on a diagonal across the mold and working first to one corner and then to the opposite corner of the mold. Remove the mold from the mortar bed.

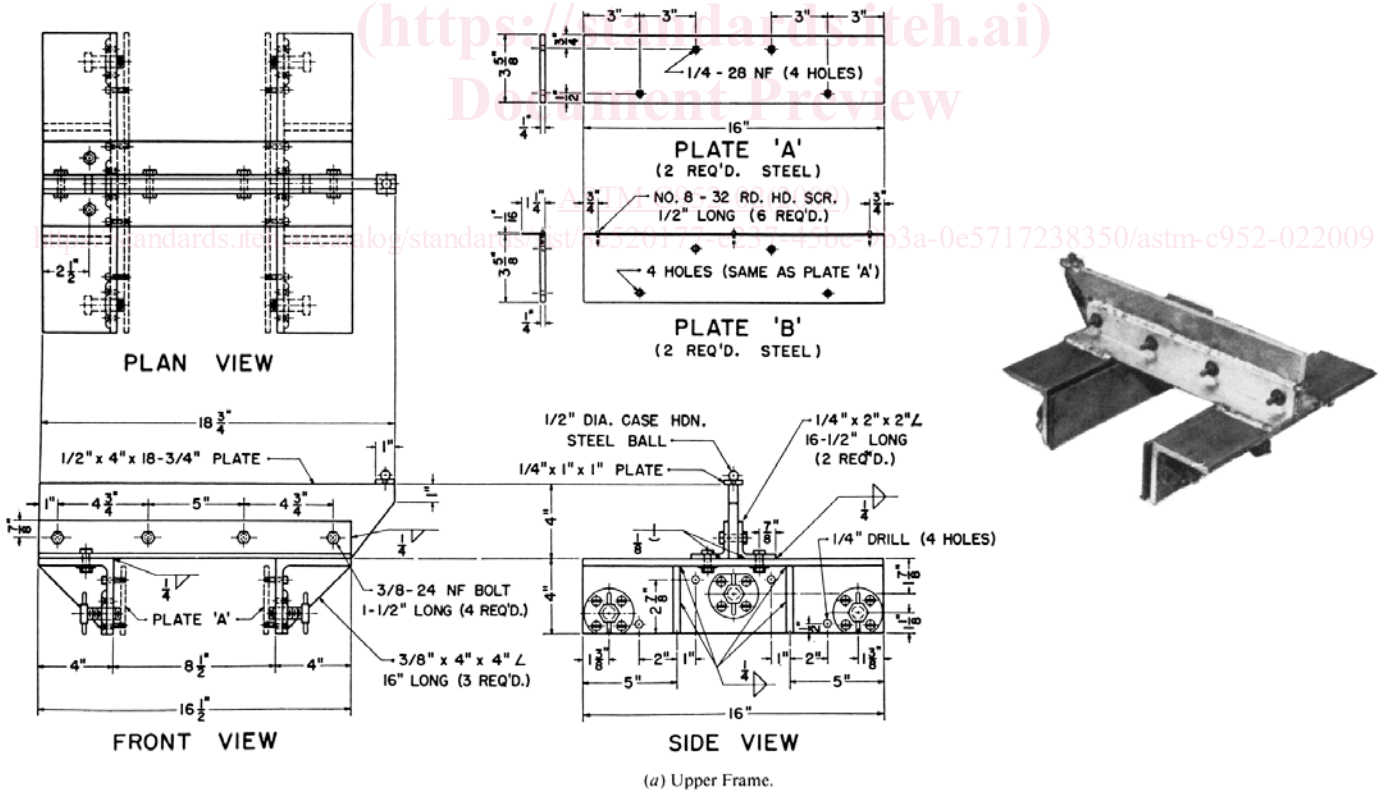
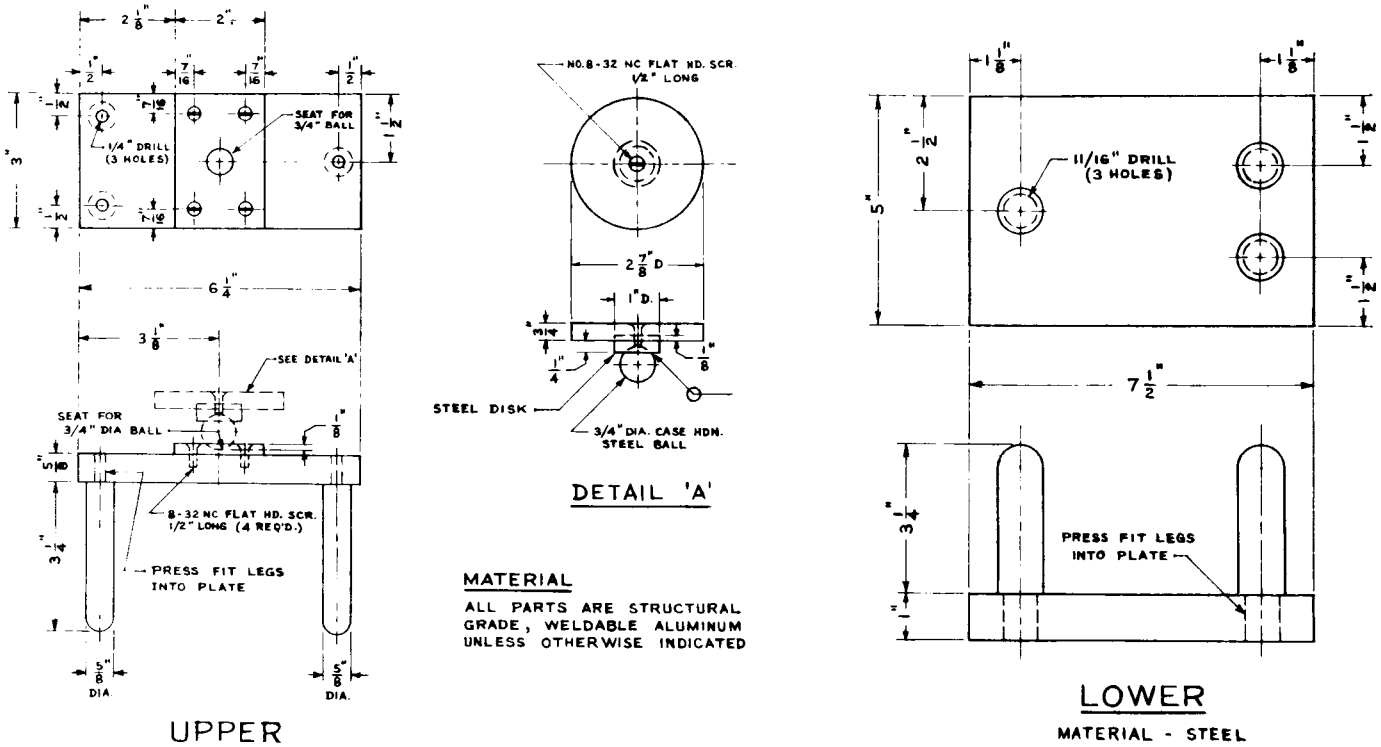

10.2.4 At 6.2.3 At the end of the 1-min time interval, place the upper brick on the mortar bed in a crosswise direction to the lower brick. Place the frame of the hammer on the top brick with the weight of the hammer held in the other hand. Drop the hammer in a frame a distance of 1½ in. (38 mm).

10.2.5 Measure 6.2.4 Measure and record the extrusion of the mortar on the top surface of the lower brick. Cut away extruded