



# Standard Specification for Paintballs Used in the Sport of Paintball<sup>1</sup>

This standard is issued under the fixed designation F1979; the number immediately following the designation indicates the year of original adoption or, in the case of revision, the year of last revision. A number in parentheses indicates the year of last reapproval. A superscript epsilon ( $\epsilon$ ) indicates an editorial change since the last revision or reapproval.

## INTRODUCTION

This specification sets forth a set of guidelines and testing procedures for the manufacturing of 0.68 caliber paintballs. The goal is to provide paintball manufacturers with a specification that promotes safety in the sport of paintball.

### 1. Scope

1.1 This specification establishes testing procedures and critical characteristics of 0.68 caliber paintballs which help define whether a paintball is suitable for use in the sport of paintball. Furthermore, the specification establishes minimum warning and package labeling to help ensure that the paintballs are used in a safe manner and that the risk of injury is reduced.

1.2 This specification does not cover non-recreational paintballs, for example, those used by law enforcement, scientific, military, or theatrical entities.

1.3 The values stated in SI units are to be regarded as the standard. The values given in parentheses are for information only.

1.4 *This specification does not purport to address all of the safety issues associated with the sport of paintball. It is the responsibility of the user of this specification to establish appropriate safety and health practices and to comply with all applicable laws and regulations.*

### 2. Terminology

#### 2.1 Definitions of Terms Specific to This Standard:

2.1.1 *cubic centimeter, n*—commonly used unit of volume extending the derived SI-unit cubic meter and corresponding to the volume of a cube measuring  $1 \times 1 \times 1$  cm.

2.1.1.1 *Discussion*—The mass of one cubic centimeter of water is approximately equal to 1 g.

2.1.2 *fill material, n*—liquid inside of a paintball.

2.1.3 *paintball, n*—spherical ball, commonly with a diameter of 17.3 mm (0.68 in.), comprised of a shell and a fill, and designed to be expelled from a paintball gun.

2.1.4 *paintball marker, n*—device specifically designed to discharge paintballs.

2.1.5 *shell*—rigid to semirigid material (generally of gelatin) that encapsulates the fill of a paintball.

### 3. General Requirements

3.1 *pH of Fill Material*—The pH of the fill material used in the paintball shall measure between 4.0 and 8.0 as measured using a 10 % solution of the fill in distilled water. Measurements shall be made using a properly calibrated pH meter. See Fig. 1 for the pH scale and pH levels for some common items.

3.2 *Paintball Fill Compatibility With Polycarbonate*—When tested in accordance with Section 4, no more than one of the three polycarbonate tensile bars exposed to the fill material shall develop a visible crack that is greater than 6.5 mm (0.256 in.) in length.

3.3 *Maximum Weight*—The paintballs shall not weigh more than 3.5 g.

3.4 *Fill Color Limitations*—The paintballs shall not contain fill material with a color mimicking that of human blood.

3.5 *Diameter of Paintball*—The diameter of the paintball as measured both polar and at the seam shall measure between 16.5 mm (0.650 in.) and 18 mm (0.709 in.).

<sup>1</sup> This specification is under the jurisdiction of ASTM Committee F08 on Sports Equipment and Facilities and is the direct responsibility of Subcommittee F08.24 on Paintball and Equipment.

Current edition approved June 1, 2009. Published July 2009. Originally approved in 1999. Last previous edition approved in 2004 as F1979–04. DOI: 10.1520/F1979-09.

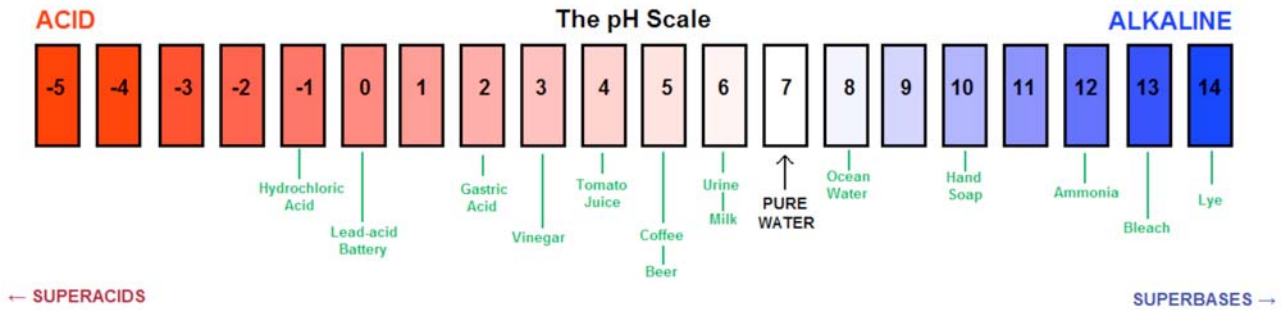

FIG. 1 The pH Scale

3.6 *Impact Breakage*—The impact breakage of the paintball shall be tested in accordance with Section 5. All ten of the paintballs that impact the target shall break upon impact.

3.7 *Environmental Safety*—Paintballs shall not contain environmentally hazardous or toxic substances as defined in CERCLA<sup>2</sup> Regulations 40CFR302.4; SARA Toxic Chemical List<sup>3</sup> Section 313; Clean Air Act<sup>4</sup>, Section 112B; and RCRA Regulations<sup>5</sup> 40FR261.24 through 40CFR261.33.

TEST METHODS

4. Paintball Compatibility with Polycarbonate

4.1 *Scope*—This test method is intended to determine the compatibility of the paintball fill with polycarbonate, the plastic material currently universally used for protective eyewear lenses in paintball.

4.2 *Summary of Test Method*—This test method involves bending polycarbonate tensile bars in a test fixture while these bars are exposed to the paintball fill material and observing how these tensile bars react to the fill. A control test is also conducted using tap water in place of the paintball fill material.

4.3 *Significance and Use*—This test method provides a means to help determine the suitability of specific paintball fill material for use in the sport of paintball. This test method

provides a relative indicator of the reaction that a polycarbonate lens would have to the paintball fill material being tested.

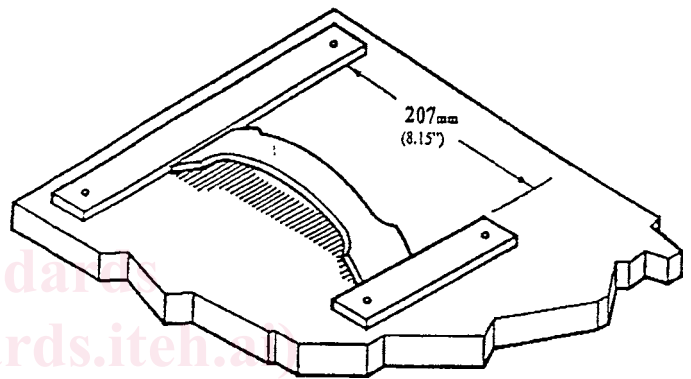

FIG. 2 Tensile Bar Shown Without Wrapping

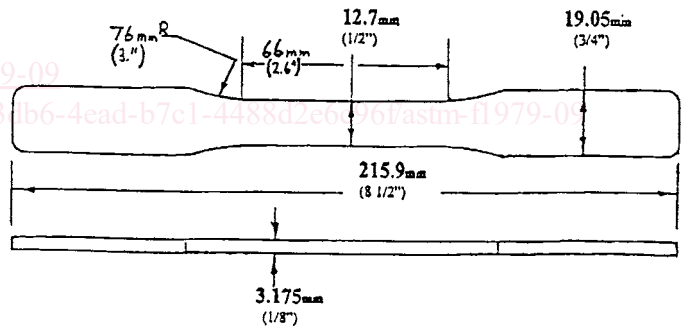

FIG. 3 Tensile Bar

4.4 *Apparatus*—This test method shall be conducted using a test fixture as shown in Fig. 2. The tensile bars<sup>6</sup> used in the test shall be molded of clear 121 grade Lexan<sup>7</sup>, polycarbonate (Fig. 3).

<sup>2</sup> U.S. Environmental Protection Agency, "Designation of Hazardous Substances List of Hazardous Substances and Reportable Quantities," *Comprehensive Environmental Response Compensation and Liabilities Act*, Bureau of Federal Affairs, 40CFR302.4, April 4, 1985.

<sup>3</sup> U.S. Environmental Protection Agency, "Superfund Amendment and Reauthorization Act," *Environmental Protection Agency Regulation*, Bureau of Federal Affairs, Title III, 1986.

<sup>4</sup> U.S. Environmental Protection Agency, "National Emission Standards for Air Pollutants List of Hazardous Air Pollutants," *Clean Air Act*, Bureau of Federal Affairs, Section 112B, 1967.

<sup>5</sup> U.S. Environmental Protection Agency, "Definition of Characteristic and Listed Hazardous Waste, Identification and Listing of Hazardous Waste," *Resource Conservation and Recovery Act*, Bureau of Federal Affairs, 40CFR261, May 19, 1980.

<sup>6</sup> The sole source of supply of the apparatus known to the committee at this time is Hi Tech Mold and Tool Inc., 1520 East St., Pittsfield, MA 01201. If you are aware of alternative suppliers, please provide this information to ASTM International Headquarters. Your comments will receive careful consideration at a meeting of the responsible technical committee,<sup>1</sup> which you may attend.

<sup>7</sup> Lexan is a trademark of GE Plastics.