**Prosthetics — Quantification of
physical parameters of ankle foot
devices and foot units**

*Prothèses — Quantification des paramètres physiques des dispositifs
de cheville/pied et unités pour les pieds*

iTeh STANDARD PREVIEW
(standards.iteh.ai)

[ISO/TS 16955:2016](https://standards.iteh.ai/catalog/standards/sist/1435ef47-3ddd-440a-b0dc-341ef37c9a5c/iso-ts-16955-2016)

<https://standards.iteh.ai/catalog/standards/sist/1435ef47-3ddd-440a-b0dc-341ef37c9a5c/iso-ts-16955-2016>



iTeh STANDARD PREVIEW
(standards.iteh.ai)

ISO/TS 16955:2016

<https://standards.iteh.ai/catalog/standards/sist/1435ef47-3ddd-440a-b0dc-341e37c9a5c/iso-ts-16955-2016>



COPYRIGHT PROTECTED DOCUMENT

© ISO 2016, Published in Switzerland

All rights reserved. Unless otherwise specified, no part of this publication may be reproduced or utilized otherwise in any form or by any means, electronic or mechanical, including photocopying, or posting on the internet or an intranet, without prior written permission. Permission can be requested from either ISO at the address below or ISO's member body in the country of the requester.

ISO copyright office
Ch. de Blandonnet 8 • CP 401
CH-1214 Vernier, Geneva, Switzerland
Tel. +41 22 749 01 11
Fax +41 22 749 09 47
copyright@iso.org
www.iso.org

Contents

	Page
Foreword	iv
Introduction	v
1 Scope	1
2 Normative references	1
3 Terms and definitions	1
4 Symbols and abbreviated terms	2
5 Requirements	2
6 Setup conditions	2
7 Quantification	3
7.1 Heel, mid-foot and toe characteristics.....	3
7.1.1 Procedure.....	3
7.1.2 Data collection and calculations.....	4
7.2 Roll-over characteristics.....	5
7.2.1 Procedure.....	5
7.2.2 Data collection and calculations.....	6
7.3 Torsional characteristic.....	7
7.3.1 Procedure.....	7
7.3.2 Data collection and calculations.....	8
7.4 Frontal plane characteristics.....	8
7.4.1 Procedure.....	8
7.4.2 Data collection and calculations.....	9
8 Accessories	10
8.1 General.....	10
8.2 Procedure.....	10
8.3 Results.....	10
Annex A (informative) Quick reference	11
Annex B (informative) Three dimensional locus of force contact point on foot-sole	12
Bibliography	17

Foreword

ISO (the International Organization for Standardization) is a worldwide federation of national standards bodies (ISO member bodies). The work of preparing International Standards is normally carried out through ISO technical committees. Each member body interested in a subject for which a technical committee has been established has the right to be represented on that committee. International organizations, governmental and non-governmental, in liaison with ISO, also take part in the work. ISO collaborates closely with the International Electrotechnical Commission (IEC) on all matters of electrotechnical standardization.

The procedures used to develop this document and those intended for its further maintenance are described in the ISO/IEC Directives, Part 1. In particular the different approval criteria needed for the different types of ISO documents should be noted. This document was drafted in accordance with the editorial rules of the ISO/IEC Directives, Part 2 (see www.iso.org/directives).

Attention is drawn to the possibility that some of the elements of this document may be the subject of patent rights. ISO shall not be held responsible for identifying any or all such patent rights. Details of any patent rights identified during the development of the document will be in the Introduction and/or on the ISO list of patent declarations received (see www.iso.org/patents).

Any trade name used in this document is information given for the convenience of users and does not constitute an endorsement.

For an explanation on the meaning of ISO specific terms and expressions related to conformity assessment, as well as information about ISO's adherence to the World Trade Organization (WTO) principles in the Technical Barriers to Trade (TBT) see the following URL: www.iso.org/iso/foreword.html.

The committee responsible for this document is ISO/TC 168 *Prosthetics and orthotics*.

[ISO/TS 16955:2016](https://standards.iteh.ai/catalog/standards/sist/1435ef47-3ddd-440a-b0dc-341e37c9a5c/iso-ts-16955-2016)

<https://standards.iteh.ai/catalog/standards/sist/1435ef47-3ddd-440a-b0dc-341e37c9a5c/iso-ts-16955-2016>

Introduction

Three major factors contribute to foot design:

- a) shape and size;
- b) strength requirements;
- c) functional performance.

Where

- a) is obvious and defined by the footwear,
- b) is specified in ISO 22523 referring to ISO 22675 (but is not suitable for use as a guide for the selection of a specific ankle-foot device or foot unit in the prescription of an individual lower limb prosthesis), and
- c) is addressed in this Technical Specification.

The AOPA group of ISO/TC 168 members between 2006 and 2009 carried out work on a method to replace design criteria for prosthetic ankle-foot devices with compliance criteria which would be applicable to both jointed devices and unjointed devices with elastic elements. In 2010, the working group “Testing” convened in Seattle, Washington and decided to work on a standard, based on the work of the AOPA group and other international groups. The vision statement was: “To develop a standard which describes quantitative methods to evaluate or assess key performance indicators of prosthetic ankle-foot devices which are correlated to measurable prosthesis user benefit.”

The subsequent work on this task has made it clear that it consists of (at least) two elements: firstly, to develop a standard which describes quantitative methods to evaluate or assess key performance indicators and secondly, to investigate and attempt to establish the correlation between these measures and relevant measures of prosthetic user benefit. This Technical Specification describes solely the quantitative methods to evaluate or assess key performance indicators.

The following definitions apply in understanding how to implement an ISO International Standard and other normative ISO deliverables (TS, PAS, IWA).

- “shall” indicates a requirement
- “should” indicates a recommendation
- “may” is used to indicate that something is permitted
- “can” is used to indicate that something is possible, for example, that an organization or individual is able to do something

In 3.3.1 of the ISO/IEC Directives, Part 2 (sixth edition, 2011) defines a requirement as an “expression in the content of a document conveying criteria to be fulfilled if compliance with the document is to be claimed and from which no deviation is permitted.”

In 3.3.2 of the ISO/IEC Directives, Part 2 (sixth edition, 2011) defines a recommendation as an “expression in the content of a document conveying that among several possibilities one is recommended as particularly suitable, without mentioning or excluding others, or that a certain course of action is preferred but not necessarily required, or that (in the negative form) a certain possibility or course of action is deprecated but not prohibited.”

iTeh STANDARD PREVIEW
(standards.iteh.ai)

ISO/TS 16955:2016

<https://standards.iteh.ai/catalog/standards/sist/1435ef47-3ddd-440a-b0dc-341ef37c9a5c/iso-ts-16955-2016>

Prosthetics — Quantification of physical parameters of ankle foot devices and foot units

1 Scope

This Technical Specification describes quantitative methods to evaluate or assess key performance indicators of prosthetic ankle foot devices.

For each method, the set-up and test configurations are described. Also included is a variety of parameters which are derived or calculated from the recorded data.

2 Normative references

The following documents, in whole or in part, are normatively referenced in this document and are indispensable for its application. For dated references, only the edition cited applies. For undated references, the latest edition of the referenced document (including any amendments) applies.

ISO 10328, *Prosthetics — Structural testing of lower-limb prostheses — Requirements and test methods*

ISO 22523:2006, *External limb prostheses and external orthoses — Requirements and test methods*

ISO 22675:2016, *Prosthetics — Testing of ankle-foot devices and foot units — Requirements and test methods*

3 Terms and definitions

For the purposes of this document, the following terms and definitions apply.

3.1

heel, mid-foot and toe characteristics

physical parameters to describe the response of the ankle foot device under load after heel strike in mid stance and prior toe off

3.2

roll-over characteristics

physical parameters to describe the sagittal plane properties of the ankle foot device relevant for the patient during stance-phase

3.3

full contact motion

physical parameter to describe the angular range of motion of the shin where the heel and the toe are in contact with the ground simultaneously

3.4

torsional characteristic

physical parameter to describe the rotational response of the ankle foot device under load and additional torque in transversal plane

3.5

frontal plane characteristics

physical parameter to describe the frontal plane response of the ankle foot device during roll over on four different tilted ground angles in frontal plane

4 Symbols and abbreviated terms

Symbols and abbreviated terms are those used in ISO 10328 and ISO 22675.

5 Requirements

To determine comprehensive ankle foot device performance and to claim compliance with this Technical Specification, all parameters shall be quantified and the strength requirements specified in ISO 22523:2006, 4.4, shall be met.

If an ankle foot device allows for different adjustments on key performance indicators, the manufacturer/submitter shall define the settings relevant for quantification. To claim compliance with this Technical Specification, all parameters shall be quantified in the specific adjustments and the strength requirements specified in ISO 22523:2006, 4.4, shall be met.

Samples for the quantification shall be from the same production batch as those for strength testing.

If not otherwise specified in this Technical Specification, the test preparation as described in ISO 10328 or ISO 22675 shall apply.

NOTE The order of tests given in [Table A.1](#) minimizes the effort for test setup and configuration.

6 Setup conditions

Use the coordinate system and test configurations specified in ISO 22675:2016, Clause 6, except P_T is located at 700 mm height on a line which is located at midfoot and parallel to the u-axis.

The test methods specified are defined for a prosthetic foot of size 26 cm and appropriate for a 70 kg amputee.

For all the described test methods, a force moment sensor shall be positioned above midfoot and at the height of 500 mm, see [Figure 1](#).

In order to quantify the influence of compliant components between knee and ankle foot device, the force moment sensor is positioned at a height of 500 mm.

A displacement sensor rigidly connected to the force moment sensor parallel to u-axis shall be used to record vertical displacement (s_u).

An angular sensor rigidly connected to the force moment sensor perpendicular to u-axis shall be used to record the torsional angle (α_u).

Using the data acquired by the sensors, the following characteristics shall be calculated.

— Stiffness at static plate angle $D_1 = (\Delta F_u / \Delta s_u)$

— Lever arm length at static plate angle $l = (M_o / F_u)$

NOTE Calculations in ranges of $F_u < 10 \% F_{u\max}$ to be considered carefully because of noise.

— Lever arm length changes at static plate angle $\Delta l_s = l_2 - l_1$

— Effective foot length at tilting plate $\Delta l_t = l_2 - l_1$

— Full contact motion at tilting plate $\Delta \alpha = \alpha_2 - \alpha_1$

- Energy at static plate angle
- Torsional stiffness
- Torsional angular range
- Effective foot width at tilting plate

$$E = \int F_u \cdot \Delta s_u$$

$$D_\alpha = (\Delta M_u / \Delta \alpha_u)$$

$$\Delta \alpha_u = \alpha_{u2} - \alpha_{u1}$$

$$\Delta l_{wt} = l_2 - l_1$$

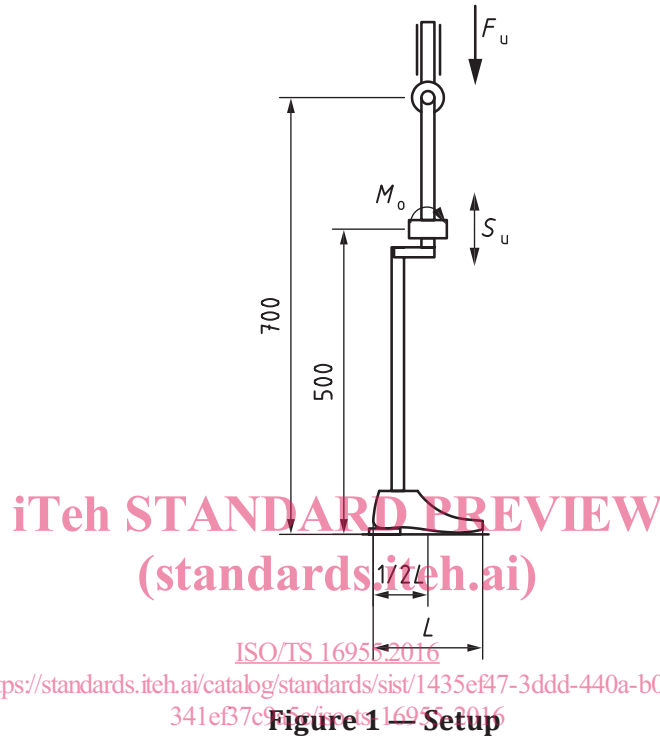

Figure 1 — Setup

7 Quantification

7.1 Heel, mid-foot and toe characteristics

7.1.1 Procedure

Perform the quantification of the heel, mid-foot and toe characteristics using the geometrical configuration of foot and foot platform described for loading in ISO 22675:2016, 13.4.1.3, using plate angles of $-7,5^\circ$ and 10° in addition (see Figure 2).

The peak force in the loading profile for quantification of the heel and toe characteristics (see Figure 3) shall be in accordance with 120 % (824 N) of the maximum body weight for which the ankle foot device is designed. The loading and unloading time shall be within $(1 \pm 0,1)$ s.

Perform the quantification of mid-foot characteristic as stated above but with the foot plate horizontal (0°) and the peak force in the loading profile (see Figure 3) in accordance with 200 % (1 373 N) of the maximum body weight for which the ankle foot device is designed. The loading and unloading time shall be within $(1 \pm 0,1)$ s.

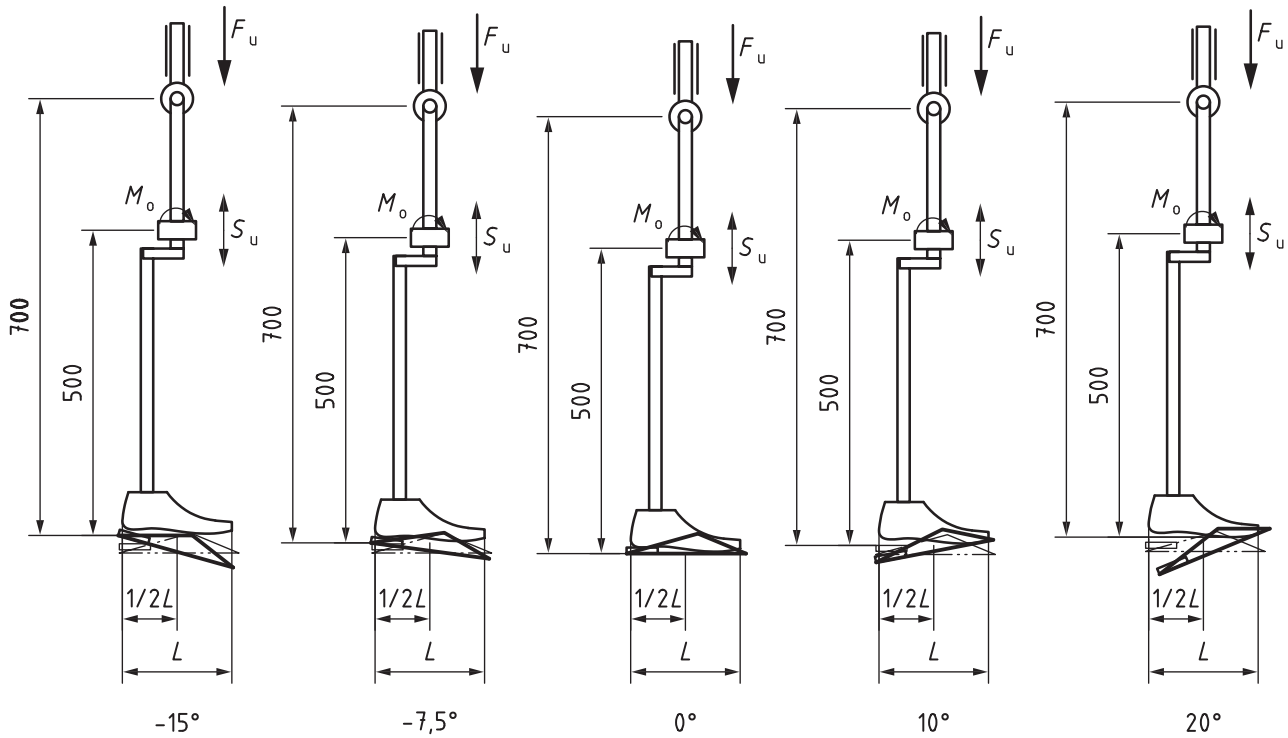
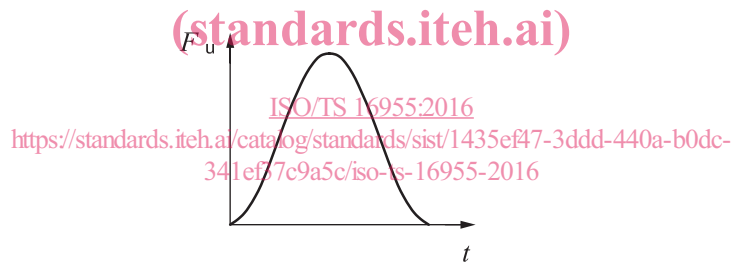

Figure 2 — Heel, mid-foot and toe characteristics (tilting angle of foot platform)



The loading profile shall be a sinusoidal wave with the peak at the specified load.

Figure 3 — Loading profile

7.1.2 Data collection and calculations

During the test, vertical displacement (s_u), vertical force (F_u) and outward moment (M_o) shall be recorded.

Using this data the following characteristics shall be calculated (see also [Table 1](#)).

Table 1 — Heel, mid-foot and toe characteristics

Test	Parameter	Measured signal/Calculated value
Heel and toe	1) Stiffness	
	2) Lever arm length at $F_{u\max}$	
	3) Lever arm length changes	
	4) Moment	
	5) Energy	
Mid-foot	1) Stiffness	
	2) Lever arm length at $F_{u\max}$	
	3) Energy	

iTeh STANDARD PREVIEW
 (standards.iteh.ai)
 ISO/TS 16955:2016
<https://standards.iteh.ai/catalog/standards/sist/1435ef47-3ddd-440a-b0dc-341ef37c9a5c/iso-ts-16955-2016>

7.2 Roll-over characteristics

7.2.1 Procedure

Perform the quantification of the roll-over characteristics (see [Figure 4](#)) using the geometrical configuration of foot and foot platform and the loading profile described in ISO 22675:2016, 13.4.2, except

- applying the force of $F_{1c\max}$ between the plate angles -15° and $+20^\circ$ (see [Figure 5](#)), and
- the duration of the loading profile shall be within $600\text{ ms} \pm 10\%$.