



SLOVENSKI STANDARD
oSIST prEN ISO 15091:2019
01-september-2019

Barve in laki - Določanje električne prevodnosti in električne upornosti (ISO/FDIS 15091:2019)

Paints and varnishes - Determination of electrical conductivity and resistance (ISO/FDIS 15091:2019)

Beschichtungsstoffe - Bestimmung der elektrischen Leitfähigkeit und des elektrischen Widerstandes (ISO/FDIS 15091:2019)

Peintures et vernis - Détermination de la conductivité et de la résistance électriques (ISO/FDIS 15091:2019)

<https://standards.iteh.ai/catalog/standards/sist/a1dd937c-fec9-461b-8166-ef1a78d048aa/sist-en-iso-15091-2020>

Ta slovenski standard je istoveten z: prEN ISO 15091

ICS:

87.040

Barve in laki

Paints and varnishes

oSIST prEN ISO 15091:2019

en,fr,de

FINAL
DRAFTINTERNATIONAL
STANDARDISO/FDIS
15091

ISO/TC 35/SC 9

Secretariat: BSI

Voting begins on:
2019-08-05Voting terminates on:
2019-10-28

Paints and varnishes — Determination of electrical conductivity and resistance

Peintures et vernis — Détermination de la conductivité et de la résistance électriques

iTeh STANDARD PREVIEW
(standards.iteh.ai)

SIST EN ISO 15091:2020

<https://standards.iteh.ai/catalog/standards/sist/a1dd937c-fec9-461b-8166-ef1a78d048aa/sist-en-iso-15091-2020>

RECIPIENTS OF THIS DRAFT ARE INVITED TO SUBMIT, WITH THEIR COMMENTS, NOTIFICATION OF ANY RELEVANT PATENT RIGHTS OF WHICH THEY ARE AWARE AND TO PROVIDE SUPPORTING DOCUMENTATION.

IN ADDITION TO THEIR EVALUATION AS BEING ACCEPTABLE FOR INDUSTRIAL, TECHNOLOGICAL, COMMERCIAL AND USER PURPOSES, DRAFT INTERNATIONAL STANDARDS MAY ON OCCASION HAVE TO BE CONSIDERED IN THE LIGHT OF THEIR POTENTIAL TO BECOME STANDARDS TO WHICH REFERENCE MAY BE MADE IN NATIONAL REGULATIONS.

ISO/CEN PARALLEL PROCESSING

Reference number
ISO/FDIS 15091:2019(E)

© ISO 2019

iTeh STANDARD PREVIEW
(standards.iteh.ai)

SIST EN ISO 15091:2020

<https://standards.iteh.ai/catalog/standards/sist/a1dd937c-fec9-461b-8166-ef1a78d048aa/sist-en-iso-15091-2020>



COPYRIGHT PROTECTED DOCUMENT

© ISO 2019

All rights reserved. Unless otherwise specified, or required in the context of its implementation, no part of this publication may be reproduced or utilized otherwise in any form or by any means, electronic or mechanical, including photocopying, or posting on the internet or an intranet, without prior written permission. Permission can be requested from either ISO at the address below or ISO's member body in the country of the requester.

ISO copyright office
CP 401 • Ch. de Blandonnet 8
CH-1214 Vernier, Geneva
Phone: +41 22 749 01 11
Fax: +41 22 749 09 47
Email: copyright@iso.org
Website: www.iso.org

Published in Switzerland

Contents

	Page
Foreword	iv
1 Scope	1
2 Normative references	1
3 Terms and definitions	1
4 General	3
4.1 Measurement of the resistance	3
4.2 Avoidance of electrolysis and polarization effects	4
5 Apparatus	5
5.1 Measuring instrument	5
5.2 Measuring cell	5
6 Sampling	5
7 Procedure	5
7.1 Test conditions	5
7.2 Viscosity of test sample	6
7.3 Number of determinations	6
7.4 Measurement of the electrical resistance or the electrical conductivity	6
8 Expression of results	6
9 Precision	6
10 Test report	7
Annex A (normative) Calibration	8
Annex B (informative) Dependence of the conductivity on the measurement temperature	10
Bibliography	11

ISO/FDIS 15091:2019(E)

Foreword

ISO (the International Organization for Standardization) is a worldwide federation of national standards bodies (ISO member bodies). The work of preparing International Standards is normally carried out through ISO technical committees. Each member body interested in a subject for which a technical committee has been established has the right to be represented on that committee. International organizations, governmental and non-governmental, in liaison with ISO, also take part in the work. ISO collaborates closely with the International Electrotechnical Commission (IEC) on all matters of electrotechnical standardization.

The procedures used to develop this document and those intended for its further maintenance are described in the ISO/IEC Directives, Part 1. In particular, the different approval criteria needed for the different types of ISO documents should be noted. This document was drafted in accordance with the editorial rules of the ISO/IEC Directives, Part 2 (see www.iso.org/directives).

Attention is drawn to the possibility that some of the elements of this document may be the subject of patent rights. ISO shall not be held responsible for identifying any or all such patent rights. Details of any patent rights identified during the development of the document will be in the Introduction and/or on the ISO list of patent declarations received (see www.iso.org/patents).

Any trade name used in this document is information given for the convenience of users and does not constitute an endorsement.

For an explanation of the voluntary nature of standards, the meaning of ISO specific terms and expressions related to conformity assessment, as well as information about ISO's adherence to the World Trade Organization (WTO) principles in the Technical Barriers to Trade (TBT) see www.iso.org/iso/foreword.html.

This document was prepared by Technical Committee ISO/TC 35, *Paints and varnishes*, Subcommittee SC 9, *General test methods for paints and varnishes*.

This second edition cancels and replaces the first edition (ISO 15091:2012), of which it constitutes a minor revision. The changes compared to the previous edition are as follows:

- the conductivity of the aqueous potassium chloride solution with a molality of 0,001 mol/kg has been corrected to 146,71 $\mu\text{S}/\text{cm}$ to correct a mistake in conductivity;
- the text has been editorially revised.

Any feedback or questions on this document should be directed to the user's national standards body. A complete listing of these bodies can be found at www.iso.org/members.html.

Paints and varnishes — Determination of electrical conductivity and resistance

1 Scope

This document specifies a method for determining the electrical conductivity and the electrical resistance of coating materials. The conductivity is usually measured for water-borne paints and varnishes, including electrodeposition coating materials, and the resistance is usually measured for solvent-borne paints and varnishes. If required, the resistivity of the coating material is calculated from either of these measurements. The method is applicable to products having a conductivity less than 5 $\mu\text{S}/\text{cm}$, corresponding to a resistivity greater than 200 $\text{k}\Omega\cdot\text{cm}$.

The conductivity of coating materials influences their processibility in the presence of an electric field. This is particularly important for electrodeposition paints and coating materials which are processed electrostatically.

2 Normative references

The following documents are referred to in the text in such a way that some or all of their content constitutes requirements of this document. For dated references, only the edition cited applies. For undated references, the latest edition of the referenced document (including any amendments) applies.

ISO 1513, *Paints and varnishes — Examination and preparation of test samples*

ISO 3696, *Water for analytical laboratory use — Specification and test methods*

ISO 4618, *Paints and varnishes — Terms and definitions*

ISO 15528, *Paints, varnishes and raw materials for paints and varnishes — Sampling*

3 Terms and definitions

For the purposes of this document, the terms and definitions given in ISO 4618 and the following apply.

ISO and IEC maintain terminological databases for use in standardization at the following addresses:

- ISO Online browsing platform: available at <https://www.iso.org/obp>
- IEC Electropedia: available at <http://www.electropedia.org/>

3.1 electrical resistance

R

ratio of the potential difference along a conductor and the current through the conductor

Note 1 to entry: Resistance is given by Ohm's law shown in [Formula \(1\)](#):

$$R = \frac{U}{I} \quad (1)$$

where

ISO/FDIS 15091:2019(E)

U is the potential difference;

I is the current.

The unit of electrical resistance is the ohm (Ω), given by:

$$1 \text{ ohm} = \frac{1 \text{ volt}}{1 \text{ ampere}}$$

The electrical resistance depends on the material of the conductor, its dimensions (length and cross-section) and its temperature.

3.2 resistivity

ρ
resistance per unit length of a material of unit cross-sectional area

Note 1 to entry: Resistivity is given by [Formula \(2\)](#):

$$\rho = R \times \frac{A}{l} \quad (2)$$

where

A is the cross-sectional area of the conductor;

l is the length of the conductor.

The unit of resistivity is the ohm metre ($\Omega \cdot \text{m}$).

3.3 conductance

G
reciprocal of the resistance

Note 1 to entry: Conductance is given by [Formula \(3\)](#):

$$G = \frac{1}{R} = \frac{I}{U} \quad (3)$$

The unit of conductance is the siemens (S):

$$1 \text{ S} = \frac{1}{\text{ohm}} = \frac{1 \text{ ampere}}{1 \text{ volt}}$$

3.4 electrical conductivity

γ
reciprocal of the *resistivity* ([3.2](#))

Note 1 to entry: Electrical conductivity is given by [Formula \(4\)](#):

$$\gamma = \frac{1}{\rho} = \frac{1}{R} \times \frac{l}{A} \quad (4)$$

The unit of electrical conductivity is the siemens reciprocal metre ($\text{S} \cdot \text{m}^{-1}$).

3.5 cell constant

c

quotient of the length and the cross-sectional area of a conductor

Note 1 to entry: It is given by [Formula \(5\)](#):

$$c = \frac{l}{A} \quad (5)$$

From [Formula \(2\)](#), it can be seen that it corresponds to the ratio of the resistance to the resistivity of the conductor material.

For the determination of the resistivity by resistance measurement, this geometrical factor, i.e. the cell constant of the measurement assembly, will need to be known.

Cell constants are given in reciprocal centimetres (cm^{-1}).

4 General

4.1 Measurement of the resistance

The resistance may be determined by;

- the measurement of the current through a sample and the voltage acting on the sample, or;
- comparison of the measured resistance with a reference resistance.

For the current/voltage measurement, usually a constant pre-determined voltage is applied to the sample, and the current is measured with a suitable measuring instrument (e.g. a moving-coil instrument or a digital instrument). The resistance is then calculated from [Formula \(1\)](#). See [Figures 1](#) to [3](#).

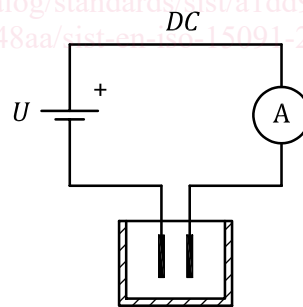

Figure 1 — Direct-current measurement

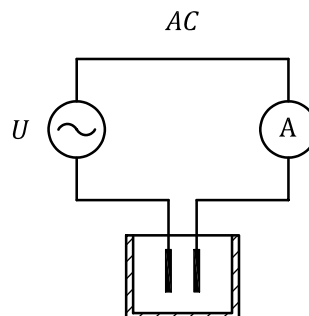

Figure 2 — Alternating-current measurement — Two-electrode cell

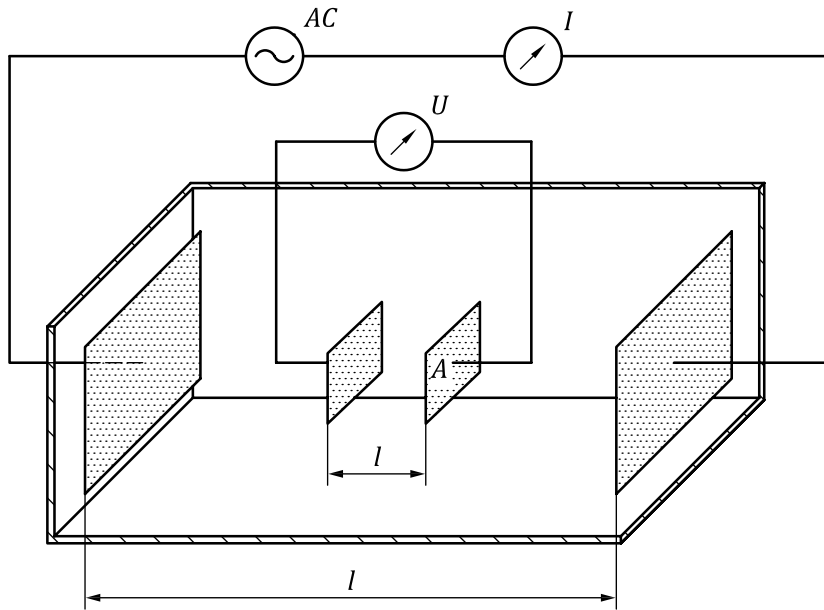
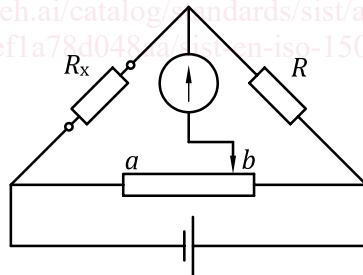

Figure 3 — Alternating-current measurement — Four-electrode cell

To compare the resistance of the sample with a reference resistance, a bridge circuit is used in which the resistances are balanced so that the bridge current becomes zero. The resistance of the sample is calculated from the ratio of the resistances of the bridge circuit. Because the bridge current is zero, errors which can result from the existence of a load on the voltage source when the voltage/current measurement method is used are avoided. The only contributions to the overall measurement error are any uncertainty in the reference resistance and any uncertainty in the adjustable resistance. See [Figure 4](#).



$$R_x = R \times \frac{a}{b}$$

Figure 4 — Wheatstone bridge

4.2 Avoidance of electrolysis and polarization effects

In order to avoid electrolysis or polarization effects which would falsify the measurement, measurements of the resistance are usually carried out using alternating current. The frequency of the voltage applied to the measuring cell should, however, be as low as possible in order to minimize the contribution made by the reactance of the measuring cell, which acts as a capacitor.