Vgrajene naprave za gašenje - Avtomatski sprinklerski sistemi - Navodila za zaščito pred potresi

Fixed firefighting systems - Automatic sprinkler systems - Guidance for earthquake bracing

Ortsfeste Brandbekämpfungsanlage - Automatische Sprinkleranlagen - Leitfaden für Erdbebensicherungen

Ta slovenski standard je istoveten z: FprCEN/TS 17551

ICS:

13.220.10	Gašenje požara	Fire-fighting
91.120.25	Zaščita pred potresi in vibracijami	Seismic and vibration protection

kSIST-TS FprCEN/TS 17551:2020**en,fr,de**

iTeh STANDARD PREVIEW
(standards.iteh.ai)

<https://standards.iteh.ai/catalog/standards/sist/49430c5e-9fdf-4b14-b39d-afe6675c244/ksist-ts-fprcen-ts-17551-2020>

TECHNICAL SPECIFICATION
SPÉCIFICATION TECHNIQUE
TECHNISCHE SPEZIFIKATION

FINAL DRAFT
FprCEN/TS 17551

September 2020

ICS 13.220.20

English Version

Fixed firefighting systems - Automatic sprinkler systems -
Guidance for earthquake bracing

Ortsfeste Brandbekämpfungsanlage - Automatische
Sprinkleranlagen - Leitfaden für Erdbebensicherungen

This draft Technical Specification is submitted to CEN members for Vote. It has been drawn up by the Technical Committee CEN/TC 191.

CEN members are the national standards bodies of Austria, Belgium, Bulgaria, Croatia, Cyprus, Czech Republic, Denmark, Estonia, Finland, France, Germany, Greece, Hungary, Iceland, Ireland, Italy, Latvia, Lithuania, Luxembourg, Malta, Netherlands, Norway, Poland, Portugal, Republic of North Macedonia, Romania, Serbia, Slovakia, Slovenia, Spain, Sweden, Switzerland, Turkey and United Kingdom.

Recipients of this draft are invited to submit, with their comments, notification of any relevant patent rights of which they are aware and to provide supporting documentation.

Warning : This document is not a Technical Specification. It is distributed for review and comments. It is subject to change without notice and shall not be referred to as a Technical Specification.



EUROPEAN COMMITTEE FOR STANDARDIZATION
COMITÉ EUROPÉEN DE NORMALISATION
EUROPÄISCHES KOMITEE FÜR NORMUNG

CEN-CENELEC Management Centre: Rue de la Science 23, B-1040 Brussels

Contents	Page
European foreword	3
Introduction	4
1 Scope.....	5
2 Normative references.....	5
3 Terms and definitions.....	5
4 Design principles	5
5 Sway bracing and sprinkler pipe support.....	6
5.1 General.....	6
5.2 Sway brace design.....	7
5.3 Anchorage for in rack sprinklers	22
5.4 Type, attachment and locations of hangers.....	23
6 Flexibility	24
6.1 General.....	24
6.2 Flexible Couplings.....	25
6.3 Seismic separation assemblies	26
7 Clearance	27
7.1 Clearance around piping through walls or floors	27
7.2 Clearance at sprinklers.....	27
8 Other provisions.....	28
8.1 Suspended ceilings	28
8.2 Water supply	28

European foreword

This document (FprCEN/TS 17551:2020) has been prepared by Technical Committee CEN/TC 191 “Fixed firefighting systems”, the secretariat of which is held by BSI.

This document is currently submitted to the Vote on TS.

iTeh STANDARD PREVIEW
(standards.iteh.ai)
<https://standards.iteh.ai/catalog/standards/sist/49430c5e-9fdf-4b14-b39d-afe6675c244/ksist-ts-fprcen-ts-17551-2020>

Introduction

This document specifies requirements for earthquake protection of automatic sprinkler systems in accordance with EN 12845 and fire hose piping systems. Requirements made herein are intended to greatly improve the likelihood that the fire protection systems will remain in working condition during earthquake and minimize or prevent any potential water damage from fixed firefighting systems leakage due to an earthquake.

iTeh STANDARD PREVIEW
(standards.iteh.ai)
<https://standards.iteh.ai/catalog/standards/sist/49430c5e-9fdf-4b14-b39d-ahcf6675c244/ksist-ts-fprcen-ts-17551-2020>

1 Scope

This document specifies requirements for earthquake protection of automatic sprinkler systems in accordance with EN 12845. This document applies only to locations in earthquake zones in accordance to EN 1998-1:2004, 3.2.1¹⁾ and for area subject to peak ground acceleration above 9 % of g.

This document does not cover all legislative requirements. In certain countries specific national regulations apply and take precedence over this document. Users of this document are advised to inform themselves of the applicability or non-applicability for this document by their national responsible authorities.

2 Normative references

The following documents are referred to in the text in such a way that some or all of their content constitutes requirements of this document. For dated references, only the edition cited applies. For undated references, the latest edition of the referenced document (including any amendments) applies.

EN 1998-1:2004¹⁾, *Eurocode 8: Design of structures for earthquake resistance - Part 1: General rules, seismic actions and rules for buildings*

EN 12845, *Fixed firefighting systems - Automatic sprinkler systems - Design, installation and maintenance*

3 Terms and definitions

For the purposes of this document, the terms and definitions given in EN 1998-1:2004¹⁾ and EN 12845 apply.

ISO and IEC maintain terminological databases for use in standardization at the following addresses:

- IEC Electropedia: available at <http://www.electropedia.org/>
- ISO Online browsing platform: available at <https://www.iso.org/obp>

4 Design principles

Requirements given in this document fall into the following seven principles:

- brace sprinkler piping and equipment to minimize uncontrolled differential movement between these installations and the attached structure; and
- provide flexibility on piping systems and on equipment where differential movement between portions of those piping systems or equipment is expected; and
- provide clearance between sprinkler piping and structural members, walls, floors or other objects so that potential damage from impact is minimized; and
- provide anchorage or restraint to minimize potential sliding and/or overturning of equipment such as the booster pump, jockey pump, tanks, controller, battery package and diesel tank; and
- use types of pipe hangers and sway bracing in accordance to EN 12845 to minimize the potential for pull-out, properly locate them and attach them to structural members only; and

1) As impacted by EN 1998-1:2004/AC:2009 and EN 1998-1:2004/A1:2013.

FprCEN/TS 17551:2020 (E)

- use types of pipe joining methods in accordance to this document to minimize potential pipe breaks; and
- provide fire protection system plans and calculations with proper verification of design and proper verification that the completed installation is in accordance with this document and installed in accordance with EN 12845.

5 Sway bracing and sprinkler pipe support**5.1 General**

Sway bracing for sprinkler systems minimize differential movement between the piping system and the structure to which it is attached.

Actual design of sway bracing is based on horizontal seismic load. Acceptable sway bracing type, orientation and attachment methods (to both the sprinkler pipe and the structure) need to simultaneously provide adequate resistance to both the horizontal seismic load and the net vertical uplift force component resulting from the horizontal seismic load less any effective offset to that vertical force component due to sprinkler piping dead weight.

For sprinkler piping within a building, there are two types sway bracing designs two-way and four-way.

Two-way braces are either longitudinal or lateral. Longitudinal and lateral braces resist differential movement perpendicular and parallel, respectively, to the axis of the pipe and are used on feed mains, cross mains, and system range pipes that are DN65 and larger in diameter.

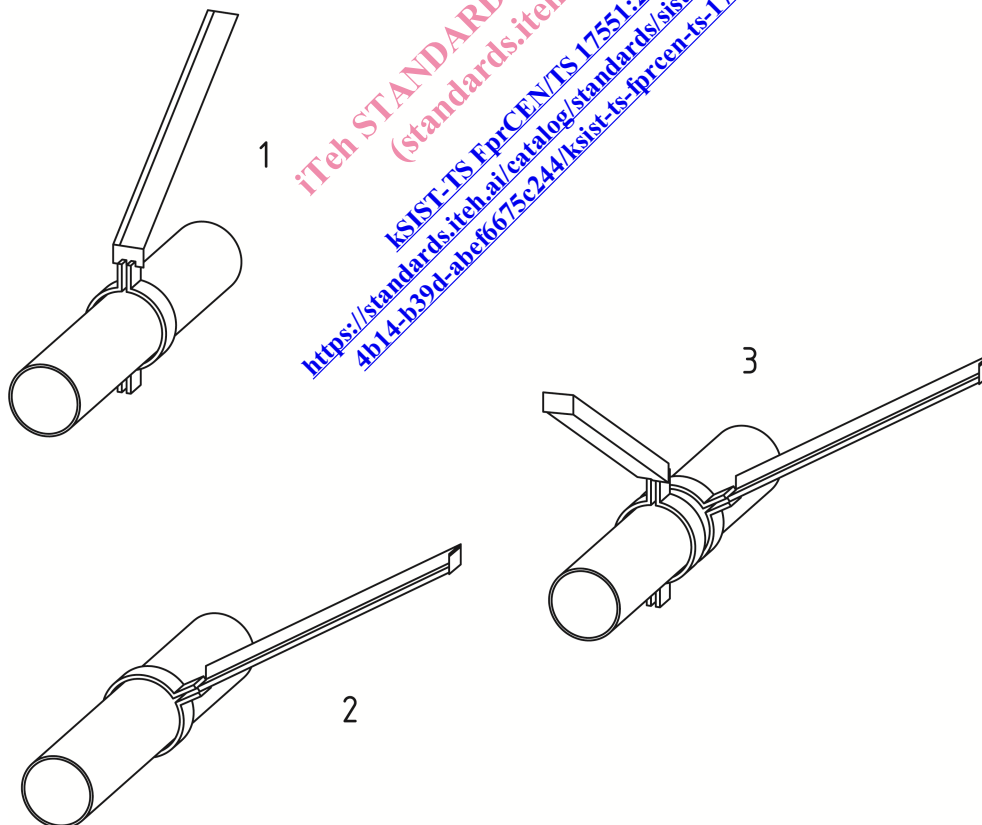
**Key**

- | | | | |
|---|----------------------------|---|----------------|
| 1 | two-way brace longitudinal | 3 | four-way-brace |
| 2 | two-way brace lateral | | |

Figure 1 — Sway bracing identification

Four-way sway bracing resists differential movement in all horizontal directions respectively, to the axis of the pipe, and is typically provided on the above-mentioned items and additionally on risers.

Where lateral and longitudinal sway bracing locations coincide, four-way bracing can be used to satisfy design requirements for both.

For sway braces to protect the fire sprinkler against damage from earthquakes, their components shall be shown to have a load capacity greater than the design earthquake load. This requires components to be cyclical load testing to failure with allowed (design) load rating calculated using a minimum 1,5 safety factor.

5.2 Sway brace design

5.2.1 Steps in designing sway brace

There are four general steps to properly design sway bracing.

- Step 1: Define sway bracing locations with respect to the sprinkler piping and to the structural members to which the bracing will be attached.
- Step 2: Calculate the seismic design load requirements for each sway bracing location.
- Step 3: Select the proper sway bracing shape, angle of attachment, size and maximum length based on the horizontal design load requirement.
- Step 4: Select the proper method to attach the sway bracing to the structure and to the piping.

5.2.2 Step 1, define sway bracing locations

5.2.2.1 Risers

A four-way sway brace shall be provided on all sprinkler risers (whether single or manifolded type) within 0,6 m of the top of the riser. Brace shall be attached to a structural element for risers located either on the outside or on the inside of the building. The use of manifolded sway bracing at the top of multiple adjacent risers requires careful design work and shall be avoided. If used, no more than two risers shall be used in a manifolded arrangement, and bracing shall be designed to carry the total loads for both risers. See Figure 2.

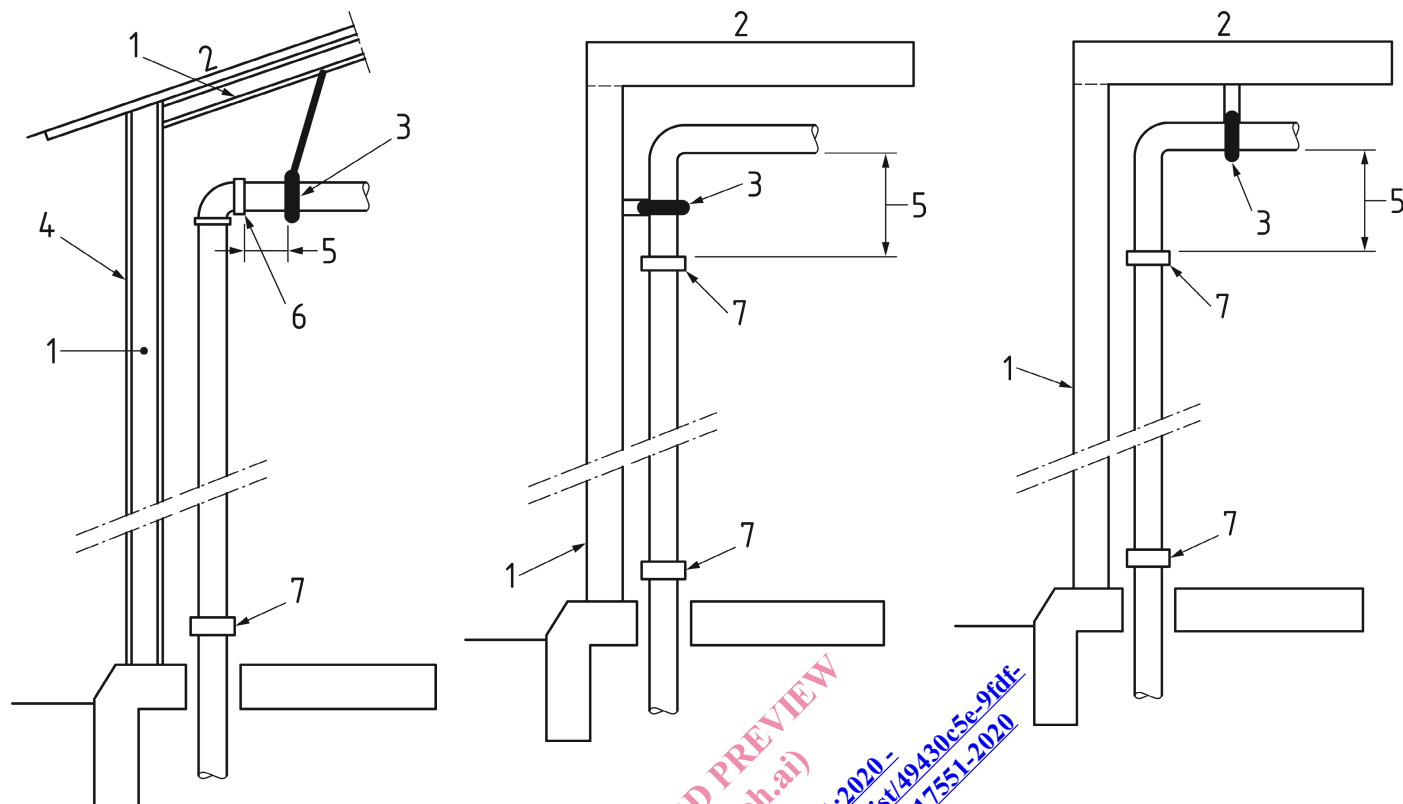

Key

- 1 structural element (given as example- roof 5 0,6 m maximum could be sloped or flat)
- 2 roof
- 3 4-way brace
- 4 cladding (not structural element)
- 5 0,6 m maximum
- 6 elbow, flexible joint
- 7 flexible coupling

Figure 2 — Location of 4-ways sway bracing for riser

Intermediate four-way sway bracing shall be provided at an interval (vertical distance) not to exceed 12 m. Where flexible couplings are used, four-way sway bracing shall be provided within 0,6 m of every other flexible coupling, with no more than two flexible couplings between sway brace locations. See Figure 3.

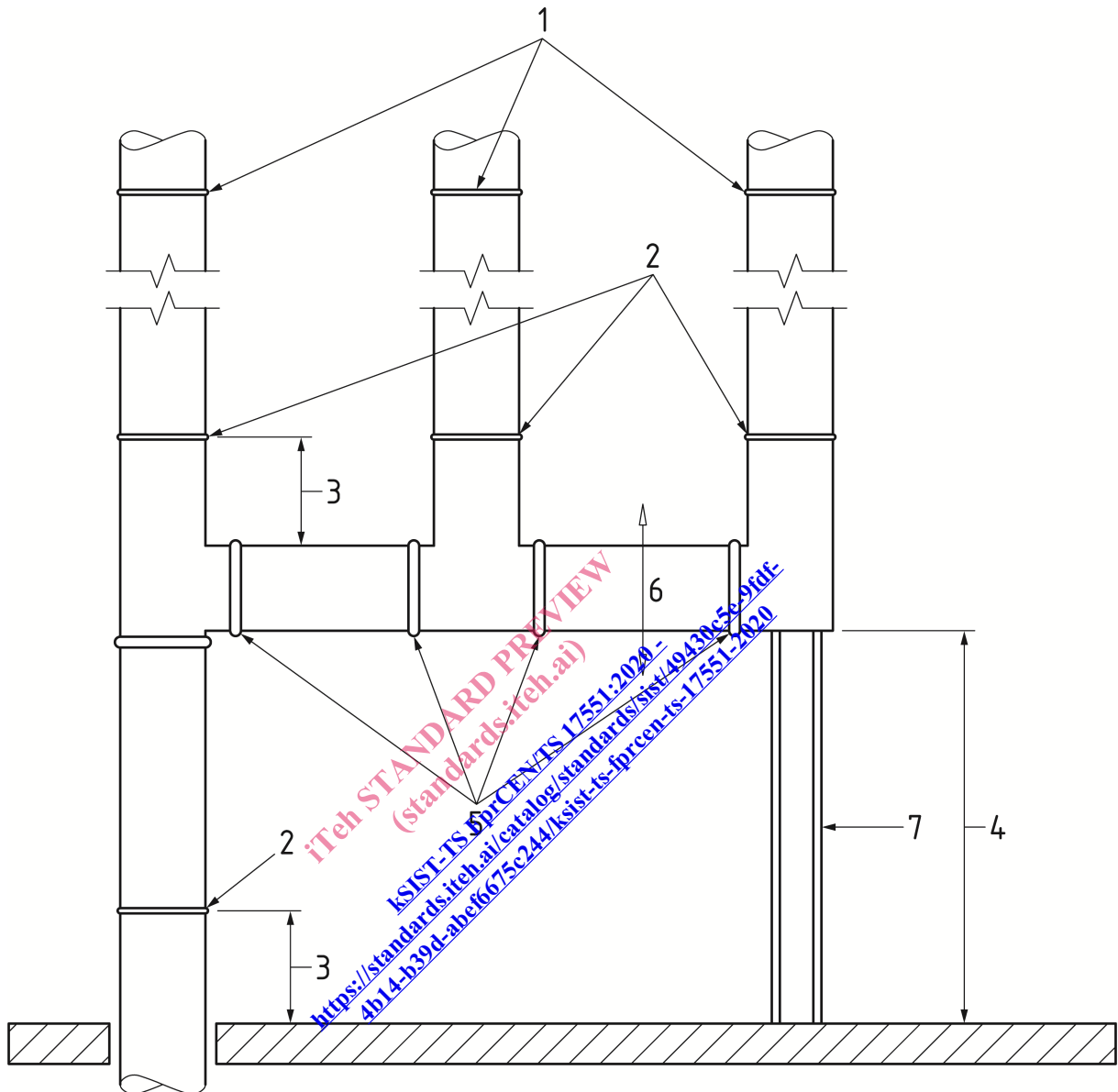
**Key**

- | | |
|---|--|
| 1 4-way sway bracing at top of riser and flexible couplings within 0,6 m (as shown in Figure 1) | 5 rigid coupling |
| 2 flexible couplings | 6 lateral sway bracing needed if run for horizontal pipe exceeds 1,8 m, measured from centreline of 2 adjacent pipes |
| 3 0,6 m maximum | 7 manifold support |
| 4 0,9 m maximum | |

Figure 3 — Location of 4-ways sway bracing for riser with manifold

In multi-storey buildings, a four-way brace shall be provided at each floor having a supply pipe.