**Acoustics — Measurement of insertion
loss of ducted silencers without flow
— Laboratory survey method**

*Acoustique — Détermination de la perte d'insertion de silencieux en
conduit sans écoulement — Méthode de contrôle en laboratoire*

iTeh STANDARD PREVIEW
(standards.iteh.ai)

[ISO 11691:2020](https://standards.iteh.ai/catalog/standards/sist/52711033-fecb-458c-81aa-f12a762c61fb/iso-11691-2020)

[https://standards.iteh.ai/catalog/standards/sist/52711033-fecb-458c-81aa-
f12a762c61fb/iso-11691-2020](https://standards.iteh.ai/catalog/standards/sist/52711033-fecb-458c-81aa-f12a762c61fb/iso-11691-2020)



iTeh STANDARD PREVIEW (standards.iteh.ai)

ISO 11691:2020

<https://standards.iteh.ai/catalog/standards/sist/52711033-fecb-458c-81aa-f12a762c61fb/iso-11691-2020>



COPYRIGHT PROTECTED DOCUMENT

© ISO 2020

All rights reserved. Unless otherwise specified, or required in the context of its implementation, no part of this publication may be reproduced or utilized otherwise in any form or by any means, electronic or mechanical, including photocopying, or posting on the internet or an intranet, without prior written permission. Permission can be requested from either ISO at the address below or ISO's member body in the country of the requester.

ISO copyright office
CP 401 • Ch. de Blandonnet 8
CH-1214 Vernier, Geneva
Phone: +41 22 749 01 11
Email: copyright@iso.org
Website: www.iso.org

Published in Switzerland

Contents

	Page
Foreword	iv
Introduction	v
1 Scope	1
2 Normative references	1
3 Terms and definitions	1
4 Test facility and arrangement	2
4.1 General.....	2
4.2 Sound measuring equipment.....	3
4.3 Sound source equipment.....	4
4.3.1 General.....	4
4.3.2 Electronic equipment, loudspeaker unit and transition element.....	4
4.3.3 Modal filter.....	4
4.4 Transition element.....	5
4.5 Test ducts and substitution duct.....	5
4.6 Reverberation room.....	5
4.7 Other measurement environments.....	5
5 Test procedure	5
6 Measurement uncertainty	6
7 Information to be recorded	6
7.1 General.....	6
7.2 Description of the silencer under test.....	6
7.3 Description of the test arrangement.....	7
7.4 Acoustical test result.....	7
8 Information to be reported	7
Bibliography	8

Foreword

ISO (the International Organization for Standardization) is a worldwide federation of national standards bodies (ISO member bodies). The work of preparing International Standards is normally carried out through ISO technical committees. Each member body interested in a subject for which a technical committee has been established has the right to be represented on that committee. International organizations, governmental and non-governmental, in liaison with ISO, also take part in the work. ISO collaborates closely with the International Electrotechnical Commission (IEC) on all matters of electrotechnical standardization.

The procedures used to develop this document and those intended for its further maintenance are described in the ISO/IEC Directives, Part 1. In particular, the different approval criteria needed for the different types of ISO documents should be noted. This document was drafted in accordance with the editorial rules of the ISO/IEC Directives, Part 2 (see www.iso.org/directives).

Attention is drawn to the possibility that some of the elements of this document may be the subject of patent rights. ISO shall not be held responsible for identifying any or all such patent rights. Details of any patent rights identified during the development of the document will be in the Introduction and/or on the ISO list of patent declarations received (see www.iso.org/patents).

Any trade name used in this document is information given for the convenience of users and does not constitute an endorsement.

For an explanation of the voluntary nature of standards, the meaning of ISO specific terms and expressions related to conformity assessment, as well as information about ISO's adherence to the World Trade Organization (WTO) principles in the Technical Barriers to Trade (TBT), see www.iso.org/iso/foreword.html.

This document was prepared by Technical Committee ISO/TC 43, *Acoustics*, Subcommittee SC 1, *Noise*.

This second edition cancels and replaces the first edition (ISO 11691:1995), which has been technically revised. The main changes compared to the previous edition are as follows:

- a modal filter has been inserted after the source to bring the standard more in line with the corresponding arrangements in ISO 7235:2003^[5], and
- in this edition, test ducts and test object should, if possible, have the same cross-sections.

Any feedback or questions on this document should be directed to the user's national standards body. A complete listing of these bodies can be found at www.iso.org/members.html.

Introduction

The insertion loss of absorbent silencers is generally not affected by the air flow, provided that the flow velocity does not exceed approximately 20 m/s in the narrowest cross-section of the silencer. In practice, non-uniform flow distributions must be considered, therefore the limit velocity of 20 m/s corresponds to a design velocity of 10 m/s to 15 m/s.

iTeh STANDARD PREVIEW (standards.iteh.ai)

[ISO 11691:2020](https://standards.iteh.ai/catalog/standards/sist/52711033-fecb-458c-81aa-f12a762c61fb/iso-11691-2020)

<https://standards.iteh.ai/catalog/standards/sist/52711033-fecb-458c-81aa-f12a762c61fb/iso-11691-2020>

iTeh STANDARD PREVIEW
(standards.iteh.ai)

ISO 11691:2020

<https://standards.iteh.ai/catalog/standards/sist/52711033-fecb-458c-81aa-f12a762c61fb/iso-11691-2020>

Acoustics — Measurement of insertion loss of ducted silencers without flow — Laboratory survey method

1 Scope

This document specifies a laboratory substitution method to determine the insertion loss without flow of ducted, mainly absorbent, circular and rectangular silencers, as well as other duct elements for use in ventilating and air-conditioning systems.

NOTE Laboratory measurement procedures for ducted silencers with superimposed flow are described in ISO 7235^[5].

This document is applicable to silencers where the design velocity does not exceed 15 m/s. As the method does not include self-generated flow noise, this document is not suitable for tests on silencers where this type of noise is of great importance for the evaluation of the silencer performance. As most silencers, particularly in offices and dwelling, have design velocities below 15 m/s, this document can often be a cost-efficient alternative to ISO 7235^[5].

The insertion loss determined according to this document in a laboratory is not necessarily the same as the insertion loss obtained in an installation in the field. Different sound and flow fields in the duct yield different results. In this document, the sound field is dominated by plane wave modes. Due to the use of regular test ducts, the results can include some flanking transmission via structural vibrations in the duct walls that sets an upper limit to the insertion loss that can be determined.

This document is intended to be used for circular silencers with diameters of 80 mm to 2 000 mm or for rectangular silencers with cross-sectional areas within the same range.

2 Normative references

The following documents are referred to in the text in such a way that some or all of their content constitutes requirements of this document. For dated references, only the edition cited applies. For undated references, the latest edition of the referenced document (including any amendments) applies.

ISO 3741, *Acoustics — Determination of sound power levels and sound energy levels of noise sources using sound pressure — Precision methods for reverberation test rooms*

IEC 60942, *Electroacoustics — Sound calibrators*

IEC 61183, *Electroacoustics — Random-incidence and diffuse-field calibration of sound level meters*

IEC 61260-1, *Electroacoustics — Octave-band and fractional-octave-band filters — Part 1: Specifications*

IEC 61672-1, *Electroacoustics — Sound level meters — Part 1: Specifications*

IEC 61672-3, *Electroacoustics — Sound level meters — Part 3: Periodic tests*

3 Terms and definitions

For the purposes of this document, the following terms and definitions apply.

ISO and IEC maintain terminological databases for use in standardization at the following addresses:

— ISO Online browsing platform: available at <https://www.iso.org/obp>

— IEC Electropedia: available at <http://www.electropedia.org/>

**3.1
insertion loss**

D

reduction in level of sound power propagating through a duct due to the insertion of a silencer into the duct system in place of a *substitution duct* (3.3)

Note 1 to entry: Insertion loss is expressed in decibels.

**3.2
test duct**

straight *standard ducts* (3.5) of constant cross-section in front of and behind the silencer under test

Note 1 to entry: The purpose of the test ducts is to separate the test object from the sound source and the reverberation room.

**3.3
substitution duct**

standard duct (3.5) element having, if possible, the same length and same connecting cross-sections as the test object

**3.4
transition element**

element which fits and connects the duct of the sound source to the *test duct* (3.2) and, in some cases, the test duct to the silencer

**3.5
standard duct**

sheet metal duct commercially available directly from stock and normally used in practical applications together with the silencer under test

Note 1 to entry: Normal wall thicknesses for standard ducts lie in the range from 0,4 mm for small circular ducts to 1,25 mm for large circular ducts. A common thickness for rectangular ducts is 0,9 mm.

iTeh STANDARD PREVIEW
(standards.iteh.ai)

ISO 11691-2020
https://standards.iteh.ai/catalog/standards/iso-11691-2020
fl2a762c61fb/iso-11691-2020

4 Test facility and arrangement

4.1 General

The test facility shall consist of the equipment shown in [Figure 1](#) and shall contain the following:

- the sound measuring equipment (see [4.2](#));
- the sound source equipment (see [4.3](#));
- the transition element (see [4.4](#));
- the test ducts (see [4.5](#));
- the substitution duct (see [4.5](#));
- the measurement environment appropriate to the standard used to determine the sound power level. (If ISO 3741 is used to determine the sound power level, a reverberation room is used, see 4.6. This is the preferred method.)

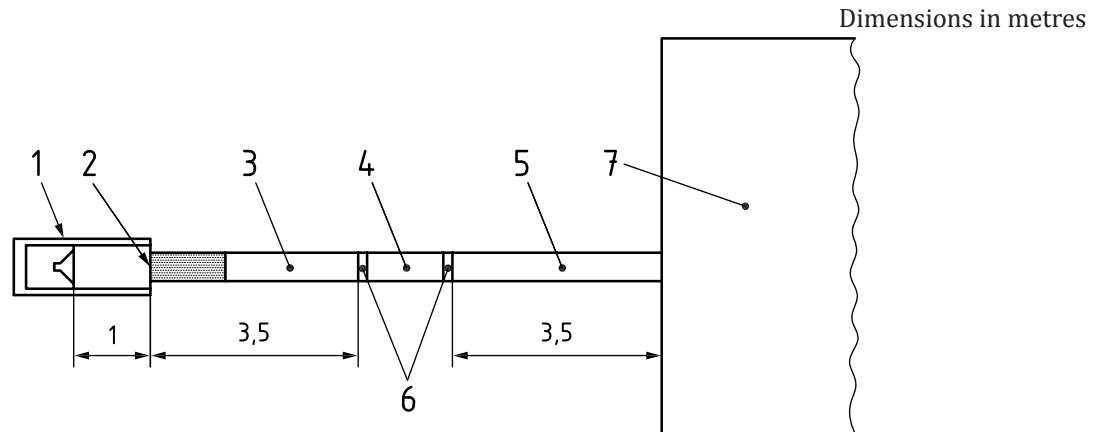

Key

- | | | | |
|---|-------------------------------|---|--|
| 1 | loudspeaker | 5 | test duct |
| 2 | transition element | 6 | transition element (if any) |
| 3 | test duct | 7 | reverberation room |
| 4 | substitution duct/test object | |  modal filter |

Figure 1 — Test setup

iTeh STANDARD PREVIEW
(standards.iteh.ai)

4.2 Sound measuring equipment

The instrumentation system, including the microphone and cable, shall meet the requirements for a class 1 instrument according to IEC 61672-1. Filters shall meet the requirements for a class 1 instrument according to IEC 61260-1.

Before and after each series of measurements, a class 1 sound calibrator complying with IEC 60942 with a maximum permitted error of $\pm 0,3$ dB shall be applied to the microphone for verifying the calibration of the entire measuring system at one or more frequencies within the frequency range of interest.

Conformance of the sound pressure level measuring instrument, including the microphone, the filters and the sound calibrator, with the relevant requirements shall be verified by the existence of a valid certificate of conformance for the measurement parameters and the environmental conditions specified in the test method. For conformance with IEC 61672-1, conformance testing in accordance with IEC 61672-3 is required for all parameters required for the application for everything except that the manufacturer's specifications can be used in place of the instruction manual. State this when full IEC 61672-1 conformance is not available. If applicable, random incidence response of the microphone shall be verified by a procedure from IEC 61183.

All conformance testing shall be conducted by a laboratory operated in accordance with ISO/IEC 17025^[8] and that meets the maximum permitted uncertainty defined in IEC 61672-1.

The sound calibrator should be calibrated at intervals not exceeding 1 year, the conformance of the reference sound source with the requirements of ISO 6926^[4] should be verified at intervals not exceeding 2 years, the conformance of the instrumentation system with the requirements of IEC 61672-1 should be verified at intervals not exceeding 2 years, and the conformance of the filters with the requirements of IEC 61260-1 should be verified at intervals not exceeding 2 years or whenever the algorithms associated with the filters are changed.

NOTE IEC 61672-3 is only applicable to devices which have been pattern approved in accordance with IEC 61672-2^[9].