

ISO/TC 43/SC 1

Secretariat: DIN

Voting begins on:
2020-05-11

Voting terminates on:
2020-07-06

Acoustics — Determination of sound power levels of noise from air-terminal devices, air-terminal units, dampers and valves by measurement in a reverberation test room

Acoustique — Détermination des niveaux de puissance acoustique du bruit émis par les bouches d'air, les unités terminales, les registres et clapets au moyen de mesurages en salle réverbérante

ITeH STANDARD PREVIEW
(standards.iteh.ai)
Full standard available on
<https://standards.iteh.ai/catalog/standards-iso/18318/3467-422f-b5e5-1bd271e7a1c2/iso-5135>

RECIPIENTS OF THIS DRAFT ARE INVITED TO SUBMIT, WITH THEIR COMMENTS, NOTIFICATION OF ANY RELEVANT PATENT RIGHTS OF WHICH THEY ARE AWARE AND TO PROVIDE SUPPORTING DOCUMENTATION.

IN ADDITION TO THEIR EVALUATION AS BEING ACCEPTABLE FOR INDUSTRIAL, TECHNOLOGICAL, COMMERCIAL AND USER PURPOSES, DRAFT INTERNATIONAL STANDARDS MAY ON OCCASION HAVE TO BE CONSIDERED IN THE LIGHT OF THEIR POTENTIAL TO BECOME STANDARDS TO WHICH REFERENCE MAY BE MADE IN NATIONAL REGULATIONS.

ISO/CEN PARALLEL PROCESSING



Reference number
ISO/FDIS 5135:2020(E)

iTeh STANDARD PREVIEW
(standards.iteh.ai)
Full standard:
<https://standards.iteh.ai/catalog/standards/sist/186749-3467-422f-b5e5-1bd271e7a1c2/iso-fdis-5135>



COPYRIGHT PROTECTED DOCUMENT

© ISO 2020

All rights reserved. Unless otherwise specified, or required in the context of its implementation, no part of this publication may be reproduced or utilized otherwise in any form or by any means, electronic or mechanical, including photocopying, or posting on the internet or an intranet, without prior written permission. Permission can be requested from either ISO at the address below or ISO's member body in the country of the requester.

ISO copyright office
CP 401 • Ch. de Blandonnet 8
CH-1214 Vernier, Geneva
Phone: +41 22 749 01 11
Fax: +41 22 749 09 47
Email: copyright@iso.org
Website: www.iso.org

Published in Switzerland

Contents

	Page
Foreword.....	iv
Introduction.....	v
1 Scope.....	1
2 Normative references.....	1
3 Terms and definitions.....	1
4 Acoustic test facilities and procedures.....	2
5 Installation and operation of equipment to be tested.....	3
5.1 General.....	3
5.2 Test installation of air-terminal devices, air-terminal units, dampers and valves for measurement of the sound radiated to the reverberation test room.....	4
5.3 Test installation of air-terminal devices, air-terminal units, dampers and valves for the measurement of the sound radiated to the reverberation test room by the connecting duct.....	6
5.4 Test installation of air-terminal devices, air-terminal units, dampers and valves for the measurement of the sound radiated to the reverberation test room directly from the equipment under test.....	7
5.5 Test installation of air-terminal units for the determination of casing radiated noise.....	8
5.6 Test procedures.....	9
6 Auxiliary facilities for acoustic testing.....	10
7 Measurements and calculations.....	10
8 Measurement uncertainty.....	11
9 Test report.....	12
Bibliography.....	14

Foreword

ISO (the International Organization for Standardization) is a worldwide federation of national standards bodies (ISO member bodies). The work of preparing International Standards is normally carried out through ISO technical committees. Each member body interested in a subject for which a technical committee has been established has the right to be represented on that committee. International organizations, governmental and non-governmental, in liaison with ISO, also take part in the work. ISO collaborates closely with the International Electrotechnical Commission (IEC) on all matters of electrotechnical standardization.

The procedures used to develop this document and those intended for its further maintenance are described in the ISO/IEC Directives, Part 1. In particular, the different approval criteria needed for the different types of ISO documents should be noted. This document was drafted in accordance with the editorial rules of the ISO/IEC Directives, Part 2 (see www.iso.org/directives).

Attention is drawn to the possibility that some of the elements of this document may be the subject of patent rights. ISO shall not be held responsible for identifying any or all such patent rights. Details of any patent rights identified during the development of the document will be in the Introduction and/or on the ISO list of patent declarations received (see www.iso.org/patents).

Any trade name used in this document is information given for the convenience of users and does not constitute an endorsement.

For an explanation of the voluntary nature of standards, the meaning of ISO specific terms and expressions related to conformity assessment, as well as information about ISO's adherence to the World Trade Organization (WTO) principles in the Technical Barriers to Trade (TBT) see www.iso.org/iso/foreword.html.

This document was prepared by ISO/TC 43, *Acoustics*, Subcommittee SC 1, *Noise*.

This third edition cancels and replaces the second edition (ISO 5135:1997), which has been technically revised. The main changes compared to the previous edition are as follows:

- replacement of rescinded and unavailable reference standards (ISO 5219:1984¹⁾ and ISO 5220:1981²⁾) with currently available and up to date standards (ANSI/ASHRAE 70 and ANSI/ASHRAE 130 or EN 12238, EN 12239 and EN 1751);
- a reference to a companion document (ISO 7235) was added to deal with transmission elements and physical elements used in the test setup;
- a clause on uncertainty was added.

Any feedback or questions on this document should be directed to the user's national standards body. A complete listing of these bodies can be found at www.iso.org/members.html.

1) Withdrawn.

2) Withdrawn.

Introduction

This document defines requirements for acoustic testing of air-terminal devices, air-terminal units, dampers and valves used in air diffusion and air distribution systems in reverberation test rooms. It is based on the use of ISO 3741, which describes the acoustic test facilities, instrumentation and procedures to be used for precision grade determination of sound power levels in octave or one-third-octave bands of a noise source.

iTeh STANDARD PREVIEW
(standards.iteh.ai)
Full standard:
<https://standards.iteh.ai/catalog/standards/sist/18674f9-3467-422f-b5e5-1bd271e7a1c2/iso-fdis-5135>

iTeh STANDARD PREVIEW
(standards.iteh.ai)

Full standard:
<https://standards.iteh.ai/catalog/standards/sist/186749-3467-422f-b5e5-1bd271e7a1c2/iso-fdis-5135>

Acoustics — Determination of sound power levels of noise from air-terminal devices, air-terminal units, dampers and valves by measurement in a reverberation test room

1 Scope

This document establishes general rules for the acoustic testing of air-terminal devices, air-terminal units, dampers and valves used in air diffusion and air distribution systems in order to determine sound power levels as defined in ISO 3741.

2 Normative references

The following documents are referred to in the text in such a way that some or all of their content constitutes requirements of this document. For dated references, only the edition cited applies. For undated references, the latest edition of the referenced document (including any amendments) applies.

ISO 3741:2010, *Acoustics — Determination of sound power levels and sound energy levels of noise sources using sound pressure — Precision methods for reverberation test rooms*

ISO 5167 (all parts), *Measurement of fluid flow by means of pressure differential devices inserted in circular cross-section conduits running full*

ISO 7235, *Acoustics — Laboratory measurement procedures for ducted silencers and air-terminal units — Insertion loss, flow noise and total pressure loss*

ANSI/ASHRAE 70, *Method of Testing the Performance of Air Outlets and Air Inlets*

ANSI/ASHRAE 130, *Laboratory Methods of Testing Air Terminal Units*

EN 1751, *Ventilation for buildings — Air terminal devices — Aerodynamic testing of damper and valves*

EN 12238, *Ventilation for buildings — Air terminal devices — Aerodynamic testing and rating for mixed flow application*

EN 12239, *Ventilation for buildings — Air terminal devices — Aerodynamic testing and rating for displacement flow applications*

3 Terms and definitions

For the purposes of this document, the following terms and definitions apply.

ISO and IEC maintain terminological databases for use in standardization at the following addresses:

- ISO Online browsing platform: available at <https://www.iso.org/obp>
- IEC Electropedia: available at <http://www.electropedia.org/>

**3.1
sound pressure level**

L_p
ten times the logarithm to the base 10 of the ratio of the square of the sound pressure, p , to the square of a reference value, p_0 , expressed in decibels

$$L_p = 10 \lg \frac{p^2}{p_0^2} \text{ dB}$$

where the reference value p_0 is 20 μPa

[SOURCE: ISO/TR 25417:2007, 2.2, modified — Notes 1 and 2 to entry have been deleted.]

**3.2
sound power level**

L_W
ten times the logarithm to the base 10 of the ratio of the sound power, P , to a reference value, P_0 , expressed in decibels

$$L_W = 10 \lg \frac{P}{P_0} \text{ dB}$$

where the reference value, P_0 , is 1 pW

Note 1 to entry: If a specific frequency weighting as specified in IEC 61672-1:2013 and/or specific frequency bands are applied, this is indicated by appropriate subscripts, e.g. L_{WA} denotes the A-weighted sound power level.

Note 2 to entry: This definition is technically in accordance with ISO 80000-8:2020, 8-15.

[SOURCE: ISO/TR 25417:2007, 2.9, modified - In the Note 2 to entry, the reference to ISO 80000-8 has been updated to its latest edition.]

**3.3
frequency range of interest**

range that includes the octave bands with nominal mid-band frequencies between 125 Hz and 8 000 Hz (optional between 63 Hz and 8 000 Hz) or the one-third-octave bands with mid-band frequencies between 100 Hz and 10 000 Hz (optional between 50 Hz and 10 000 Hz)

Note 1 to entry: The user is encouraged to qualify the room in the 63 Hz octave band and include this sound. Some equipment can generate significant sound in the 63 Hz octave band.

4 Acoustic test facilities and procedures

The acoustic test facilities, instrumentation and procedures that shall be used, including room qualification tests, are described in ISO 3741.

This document is applicable to equipment operating under steady state conditions and with a volume not greater than 5 % of the volume of the reverberation test room.

If the equipment is greater than 2 % up to 5 % of the room volume, then the test room shall be qualified according to ISO 3741 with all equipment present in the room. The test facilities shall be qualified for broad-band sound per the corresponding annex in ISO 3741.

5 Installation and operation of equipment to be tested

5.1 General

5.1.1 When the equipment is mounted closer than 1,0 m to one or more reflecting planes, the sound power level can depend strongly on the position of the equipment relative to these planes. Therefore, install the equipment to be tested in a position representative of normal usage. [Figure 1](#) illustrates the overall test environment, with the specific details of each type shown in [Figures 2](#) to [7](#).

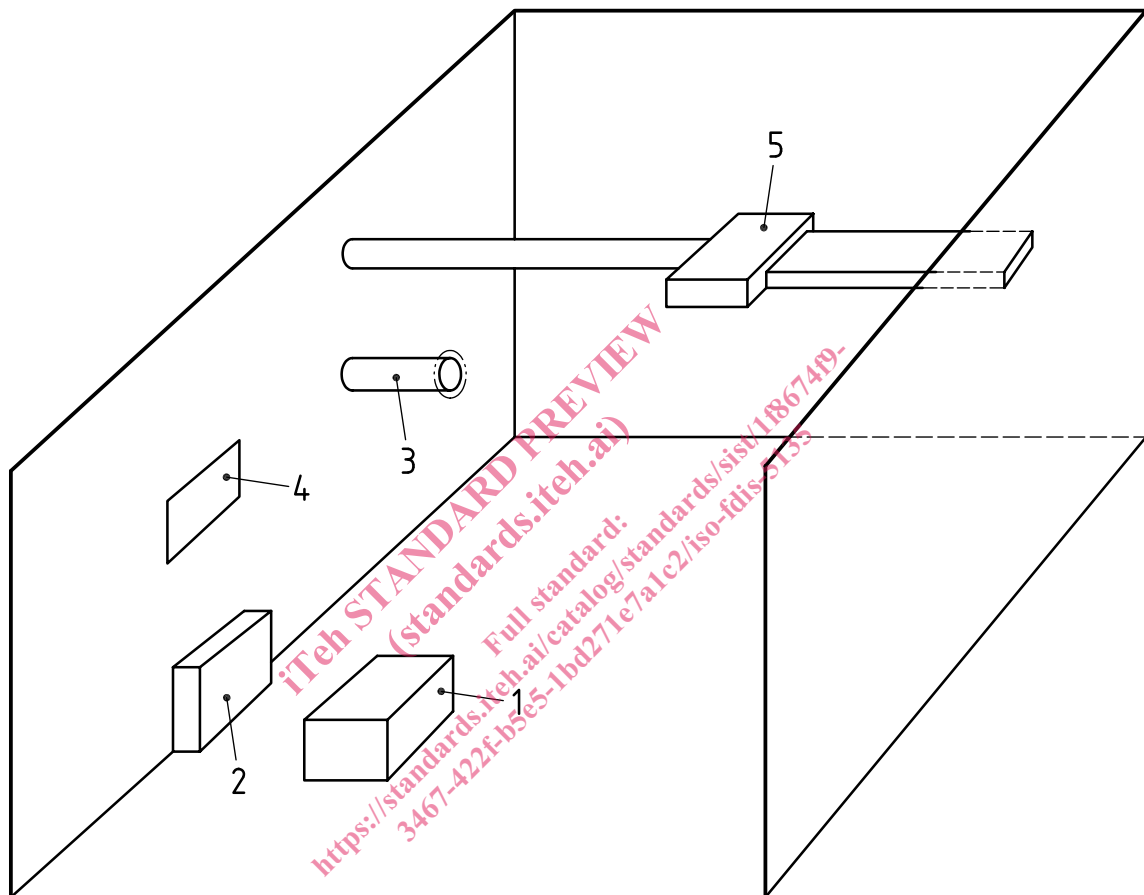

Key

- 1 air-terminal device installed on or against a surface (see [Figure 2](#))
- 2 air-terminal device installed at intersection of two surfaces (see [Figure 3](#))
- 3 air-terminal device installed away from surface (see [Figure 4](#))
- 4 air-terminal device installed outside room boundary (see [Figures 5](#) and [6](#))
- 5 mounting detail for air-terminal unit to determine casing radiated sound (see [Figure 7](#))

NOTE See [5.2](#), [5.3](#) and [5.4](#) for mounting details.

Figure 1 — Location of equipment in test room

Reflecting planes may, for practical reasons, be simulated by panels with an area-related mass greater than 7 kg/m². Such panels shall extend at least 1,0 m in all directions measured from any edge of the equipment under test. The distance of 1,0 m is a deviation from the required 1,5 m specified in ISO 3741. These panels shall be vibration isolated from the equipment under test. If such a panel is used, the room with the reflecting panel shall be qualified for broad-band sound per the corresponding annex in ISO 3741.

5.1.2 Supply air to the equipment under test or exhaust air from it through a test installation in accordance with either ANSI/ASHRAE 130 and ANSI/ASHRAE 70 or EN 12238, EN 12239 and EN 1751. If EN 12238, EN 12239 and EN 1751 are followed, the airflow rate shall be measured using instruments in accordance with the ISO 5167 series. Airflow measuring devices sometimes generate sound. If the sound generated by the device adds to the sound produced by the unit, it is recommended that a two-step process is used in which the airflow is measured first and then measure sound using the same static pressure or pressure differentials.

5.1.3 Include air-flow control accessories (dampers, deflectors, straighteners, equalizers, etc.) normally used in conjunction with the equipment under test in the test setup. Locate and set them in the same manner as recommended for the application of the equipment.

5.2 Test installation of air-terminal devices, air-terminal units, dampers and valves for measurement of the sound radiated to the reverberation test room

5.2.1 Position air-terminal devices normally installed in a boundary surface no closer than 1,0 m to the intersection of any adjacent surface and away from any position of boundary surface symmetry, as shown in Figure 2. The room surface on which the equipment is located can be the floor as shown, any wall, or the ceiling.

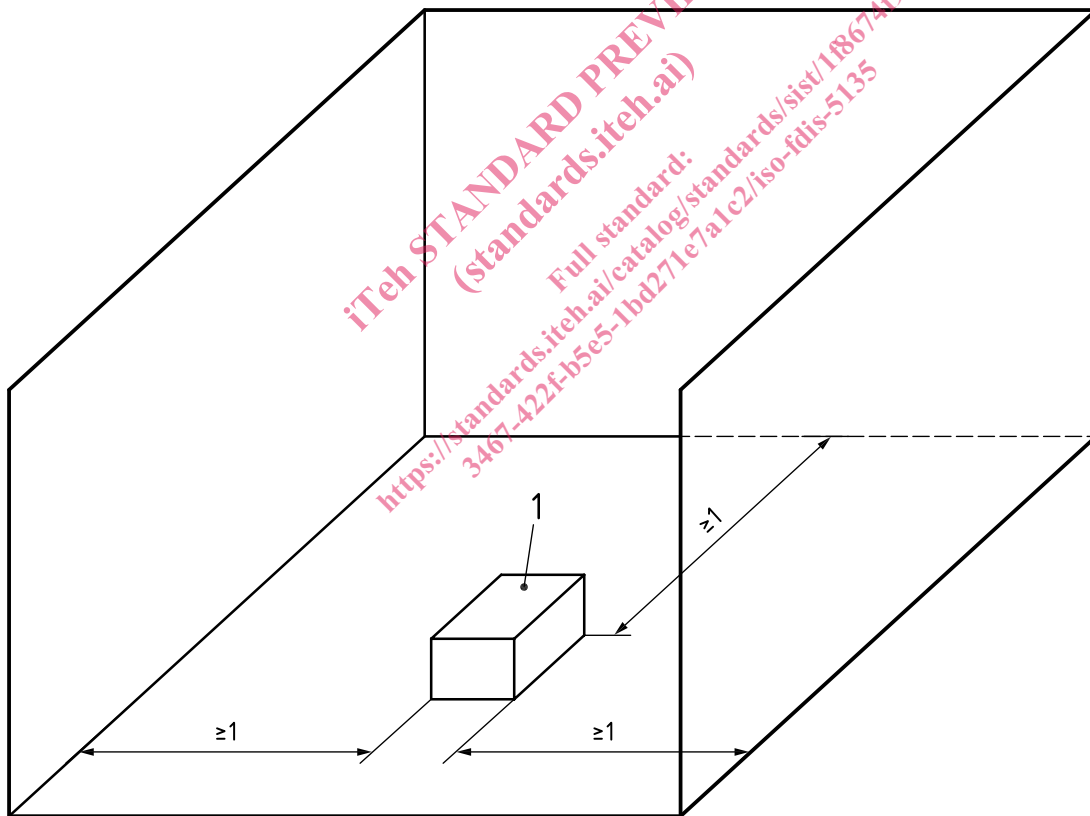

Key

1 air-terminal device installed on or against a surface

Figure 2 — Mounting detail for air-terminal device installed on or against a surface as described in ASHRAE 130, EN 12238 or EN 12239

5.2.2 Mount air-terminal devices normally used at the intersection of two surfaces at the intersection of the two surfaces not closer than 1,0 m to a third surface as shown in Figure 3.