**Blanks for superabrasive cutting-off
wheels — Mounting and fixing bores
— Building construction and civil
engineering**

*Âmes pour meules de tronçonnage superabrasives — Alésages de
montage et de fixation — Bâtiment et génie civil*

ITeH STANDARD PREVIEW
(standards.iteh.ai)
Full standard:
<https://standards.iteh.ai/catalog/standards/sui/3783b-667b-4a35-8f18-4bd33a6285fa/iso-21538-2015>

PROOF / ÉPREUVE



iTeh STANDARD PREVIEW
(standards.iteh.ai)
Full standard:
<https://standards.iteh.ai/catalog/standards/sist/f3f783b-667b-4a35-8f18-4bd33a6285fa/iso-21538-2016>



COPYRIGHT PROTECTED DOCUMENT

© ISO 2015, Published in Switzerland

All rights reserved. Unless otherwise specified, no part of this publication may be reproduced or utilized otherwise in any form or by any means, electronic or mechanical, including photocopying, or posting on the internet or an intranet, without prior written permission. Permission can be requested from either ISO at the address below or ISO's member body in the country of the requester.

ISO copyright office
Ch. de Blandonnet 8 • CP 401
CH-1214 Vernier, Geneva, Switzerland
Tel. +41 22 749 01 11
Fax +41 22 749 09 47
copyright@iso.org
www.iso.org

Contents

	Page
Foreword	iv
1 Scope	1
2 Normative references	1
3 Dimensions	1
4 Designation	5

iTeh STANDARD PREVIEW
(standards.iteh.ai)
Full standard:
<https://standards.iteh.ai/catalog/standards/sist/f3f783b-667b-4a35-8f18-4bd33a6285fa/iso-21538-2016>

Foreword

ISO (the International Organization for Standardization) is a worldwide federation of national standards bodies (ISO member bodies). The work of preparing International Standards is normally carried out through ISO technical committees. Each member body interested in a subject for which a technical committee has been established has the right to be represented on that committee. International organizations, governmental and non-governmental, in liaison with ISO, also take part in the work. ISO collaborates closely with the International Electrotechnical Commission (IEC) on all matters of electrotechnical standardization.

The procedures used to develop this document and those intended for its further maintenance are described in the ISO/IEC Directives, Part 1. In particular the different approval criteria needed for the different types of ISO documents should be noted. This document was drafted in accordance with the editorial rules of the ISO/IEC Directives, Part 2 (see www.iso.org/directives).

Attention is drawn to the possibility that some of the elements of this document may be the subject of patent rights. ISO shall not be held responsible for identifying any or all such patent rights. Details of any patent rights identified during the development of the document will be in the Introduction and/or on the ISO list of patent declarations received (see www.iso.org/patents).

Any trade name used in this document is information given for the convenience of users and does not constitute an endorsement.

For an explanation on the meaning of ISO specific terms and expressions related to conformity assessment, as well as information about ISO's adherence to the WTO principles in the Technical Barriers to Trade (TBT) see the following URL: [Foreword - Supplementary information](#)

The committee responsible for this document is ISO/TC 29, *Small tools*, Subcommittee SC 5, *Grinding wheels and abrasives*.

This second edition cancels and replaces the first edition (ISO 21538:2004), of which it constitutes a minor revision.

Blanks for superabrasive cutting-off wheels — Mounting and fixing bores — Building construction and civil engineering

1 Scope

This International Standard specifies dimensions for mounting and fixing bores in blanks. These mounting and fixing bores comply with the relevant dimensions of the clamping flanges specified in ISO 21537-2.

2 Normative references

The following documents, in whole or in part, are normatively referenced in this document and are indispensable for its application. For dated references, only the edition cited applies. For undated references, the latest edition of the referenced document (including any amendments) applies.

ISO 2768-1, *General tolerances — Part 1: Tolerances for linear and angular dimensions without individual tolerance indications*

ISO 21537-2, *Clamping flanges for superabrasive cutting-off wheels — Part 2: Building and construction*

3 Dimensions

The dimensions of a centre bore without hole circle (type A), of a centre bore with one hole circle for a driving pin (type B), of a centre bore with up to two hole circles for driving pins (type C), of a centre bore with up to two hole circles for mounting (type D) and of a centre bore with one hole circle for driving pins and one for mounting (type E) are shown on [Figures 1 to 5](#), respectively and are given in [Table 1](#).

Details which are not specified shall be chosen according to need.

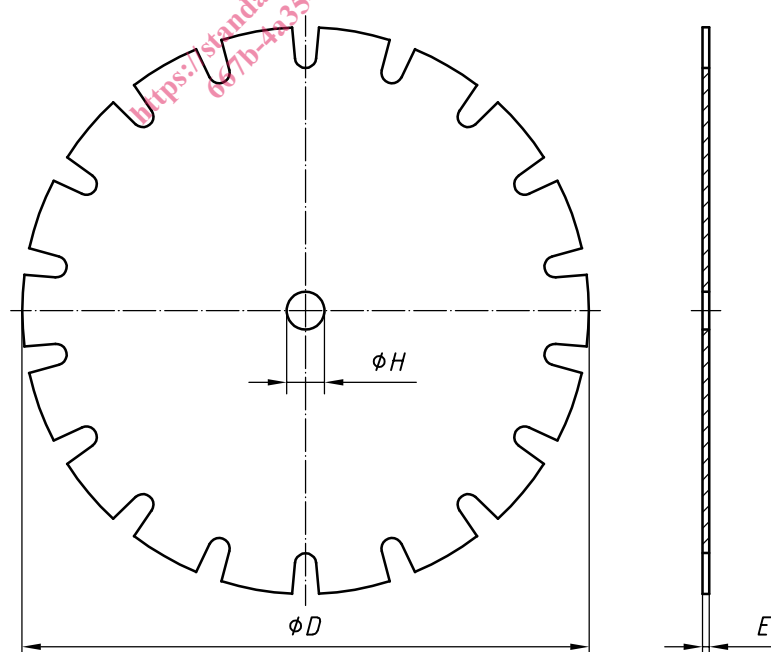

Figure 1 — Type A

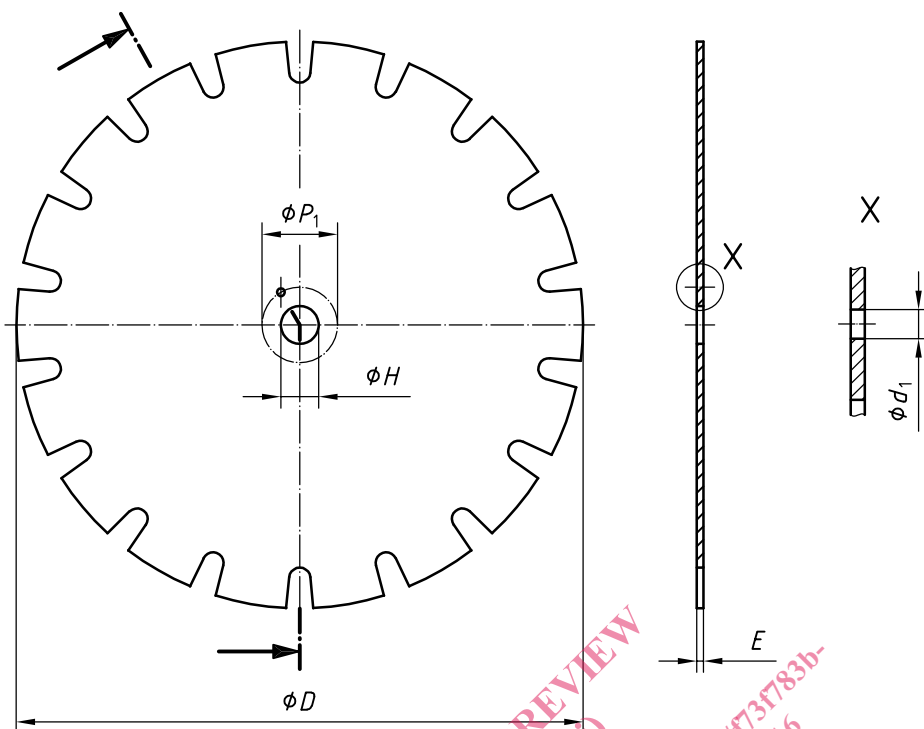

Figure 2 — Type B

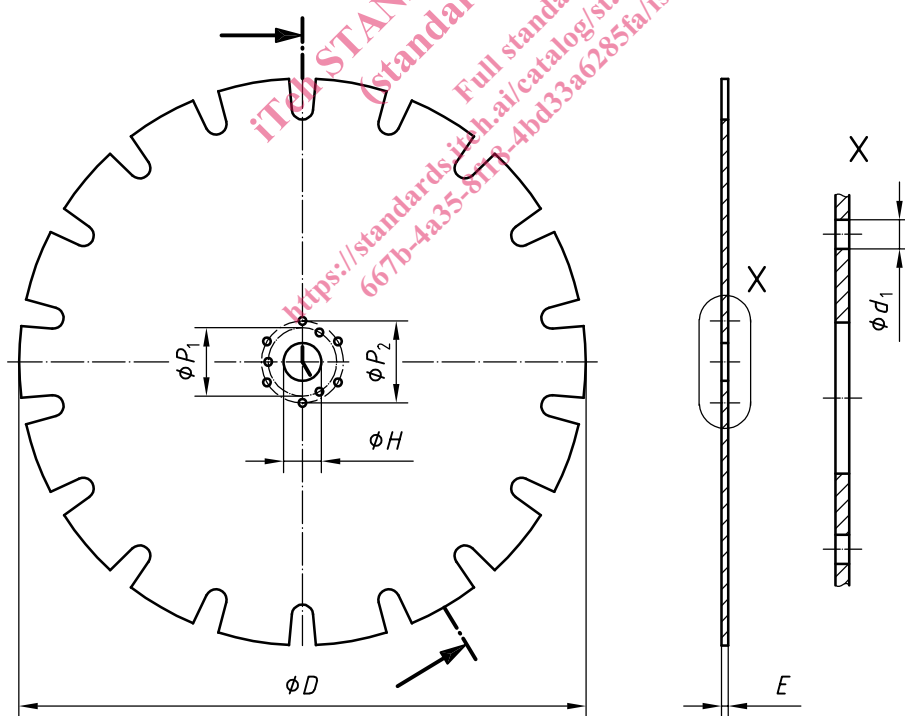

Figure 3 — Type C

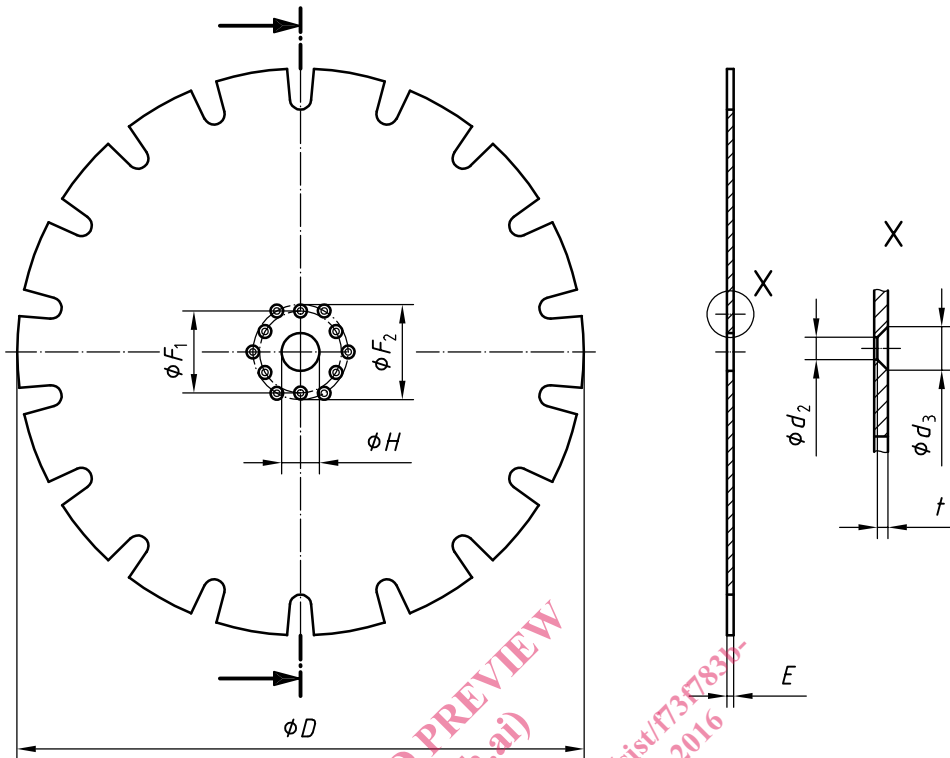

Figure 4 — Type D

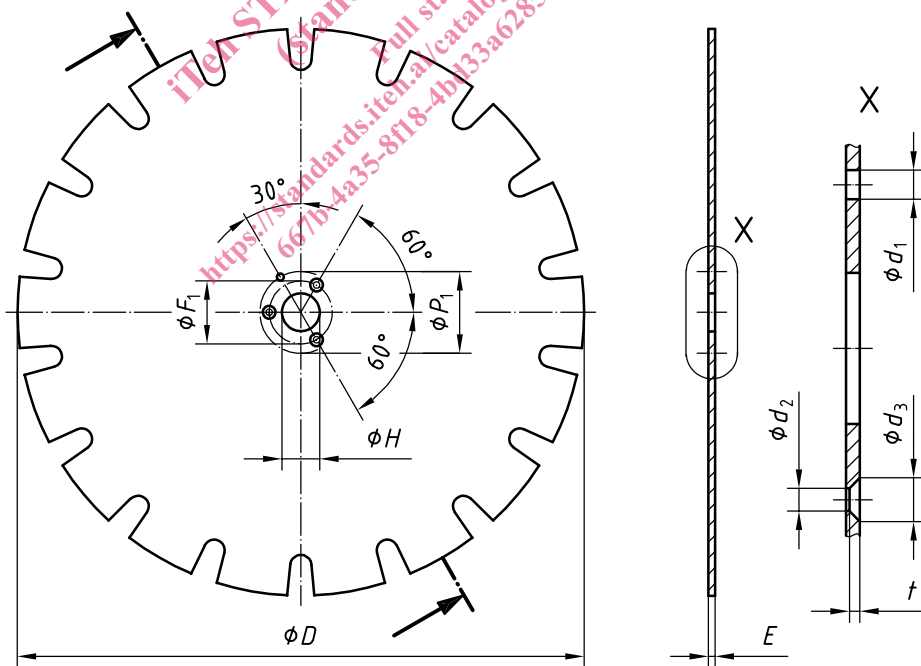

Figure 5 — Type E

Table 1 — Dimensions of mounting and fixing bores

Dimensions in millimetres
General tolerances ISO 2768 m

D	E	H	d ₁	d ₂ ^a	d ₃	P ₁ and P ₂ ±0,1				Number of driving holes	F ₁ and F ₂ ±0,1						Maxi- mum number of fixing bores																	
						57,4	80	100	120		45	60	90	110	125	130																		
D ≤ 300	1,6	20	—	—	—	—	—	—	—	—	—	—	—	—	—	—																		
		25,4	11,5			X				1																								
		30																																
300 < D ≤ 350	2,2	25,4	11,5	—	—	X	—	—	—	1	—	—	—	—	—	—																		
		30																																
350 < D ≤ 400	2,2	25,4	11,5	5,5	10,4	X	—	—	—	0 or 1	X	—	—	—	—	—	4 × 90°																	
		35															—	—	—	—	—	—	—	—	—	—	—	—	—	—				
		50															6,6	12,6	X	—	—	—	—	—	—	X	—	—	—	—	—	6 × 60°		
		60															—	—	—	—	—	—	—	—	—	—	—	—	—	—	—	—		
400 < D ≤ 500	2,5	25,4	11,5	9	17,3	X	—	—	—	0 or 1	—	—	X	—	—	—	—	6 × 60° on F ₁																
		35																	—	—	—	—	—	—	—	—	—	—	—	—	—	—		
		50																	—	—	—	—	—	—	—	—	—	—	—	—	—	—	—	—
		60																	—	—	—	—	—	—	—	—	—	—	—	—	—	—	—	—
500 < D ≤ 600	2,8	25,4	11,5	9	17,3	X	—	—	—	0 or 1	—	—	X	—	—	—	—	—																
		35																	—	—	—	—	—	—	—	—	—	—	—	—	—	—		
		50																	—	—	—	—	—	—	—	—	—	—	—	—	—	—	—	—
		60																	—	—	—	—	—	—	—	—	—	—	—	—	—	—	—	—
600 < D ≤ 700	3,0	25,4	11,5	9	17,3	X	—	—	—	0 or 1	—	—	X	X	X	X	—	—																
		35																	—	—	—	—	—	—	—	—	—	—	—	—	—	—		
		50																	—	—	—	—	—	—	—	—	—	—	—	—	—	—	—	—
		60																	—	—	—	—	—	—	—	—	—	—	—	—	—	—	—	—
700 < D ≤ 900	3,0	25,4	11,5	9	17,3	X	—	—	X	0, 1 or 4	—	—	X	X	X	X	—	—																
		35																	—	—	—	—	—	—	—	—	—	—	—	—	—	—		
		50																	—	—	—	—	—	—	—	—	—	—	—	—	—	—	—	—
		60																	—	—	—	—	—	—	—	—	—	—	—	—	—	—	—	—
900 < D ≤ 1 000	3,5	25,4	11,5	9	17,3	X	—	—	X	0, 1 or 4	—	—	X	X	X	X	—	—																
		35																	—	—	—	—	—	—	—	—	—	—	—	—	—	—		
		50																	—	—	—	—	—	—	—	—	—	—	—	—	—	—	—	—
		60																	—	—	—	—	—	—	—	—	—	—	—	—	—	—	—	—
1 000 < D ≤ 2 000	3,5	25,4	11,5	9	17,3	X	—	—	X	0, 1 or 4	—	—	X	X	X	X	—	—																
		35																	—	—	—	—	—	—	—	—	—	—	—	—	—	—		
		50																	—	—	—	—	—	—	—	—	—	—	—	—	—	—	—	—
		60																	—	—	—	—	—	—	—	—	—	—	—	—	—	—	—	—

^a If the thickness of the blank is less than the depth, *t*, then *d*₂ results if dimension *d*₃ is respected.

4 Designation

EXAMPLE A blank for a superabrasive cutting-off wheel mounting and fixing bores type C with $D = 900$ mm, $H = 60$ mm, $P_1 = 100$ mm and $P_2 = 120$ mm is designated as follows:

Mounting bore ISO 21538 - C 900 × 60 × 100/120

iTeh STANDARD PREVIEW
(standards.iteh.ai)
Full standard:
<https://standards.iteh.ai/catalog/standards/sist/f3f783b-667b-4a35-8f18-4bd33a6285fa/iso-21538-2016>