**Optics and photonics — Preparation
of drawings for optical elements and
systems —**

**Part 14:
Wavefront deformation tolerance**

iTeh STANDARD PREVIEW
*Optique et photonique — Préparation des dessins pour éléments et
systèmes optiques —
(standards.iteh.ai)
Partie 14: Tolérance de déformation du front d'onde*

[ISO 10110-14:2018](https://standards.iteh.ai/catalog/standards/sist/1ce49626-fla6-4a39-bca0-832f29633d1d/iso-10110-14-2018)

<https://standards.iteh.ai/catalog/standards/sist/1ce49626-fla6-4a39-bca0-832f29633d1d/iso-10110-14-2018>



iTeh STANDARD PREVIEW
(standards.iteh.ai)

ISO 10110-14:2018

<https://standards.iteh.ai/catalog/standards/sist/1ce49626-fla6-4a39-bca0-832f29633d1d/iso-10110-14-2018>



COPYRIGHT PROTECTED DOCUMENT

© ISO 2018

All rights reserved. Unless otherwise specified, or required in the context of its implementation, no part of this publication may be reproduced or utilized otherwise in any form or by any means, electronic or mechanical, including photocopying, or posting on the internet or an intranet, without prior written permission. Permission can be requested from either ISO at the address below or ISO's member body in the country of the requester.

ISO copyright office
CP 401 • Ch. de Blandonnet 8
CH-1214 Vernier, Geneva
Phone: +41 22 749 01 11
Fax: +41 22 749 09 47
Email: copyright@iso.org
Website: www.iso.org

Published in Switzerland

Contents

	Page
Foreword	iv
Introduction	v
1 Scope	1
2 Normative references	1
3 Terms and definitions	1
4 Specification of tolerances for wavefront deformation	1
4.1 General	1
4.2 Units	2
4.3 Wavelength	3
4.4 Target aberrations	3
5 Indication in drawings	3
5.1 General	3
5.2 Code number	3
5.2.1 Basic forms	3
5.2.2 Additional forms	5
5.3 Area	6
5.4 Location	6
5.5 Indication of the object point location	8
5.6 Specification of the image point location	9
5.7 Indication of target aberrations	9
6 Examples of tolerance indications	9
Bibliography	12

[ISO 10110-14:2018](https://standards.iteh.ai/catalog/standards/sist/1ce49626-fla6-4a39-bca0-832f29633d1d/iso-10110-14-2018)

<https://standards.iteh.ai/catalog/standards/sist/1ce49626-fla6-4a39-bca0-832f29633d1d/iso-10110-14-2018>

Foreword

ISO (the International Organization for Standardization) is a worldwide federation of national standards bodies (ISO member bodies). The work of preparing International Standards is normally carried out through ISO technical committees. Each member body interested in a subject for which a technical committee has been established has the right to be represented on that committee. International organizations, governmental and non-governmental, in liaison with ISO, also take part in the work. ISO collaborates closely with the International Electrotechnical Commission (IEC) on all matters of electrotechnical standardization.

The procedures used to develop this document and those intended for its further maintenance are described in the ISO/IEC Directives, Part 1. In particular, the different approval criteria needed for the different types of ISO documents should be noted. This document was drafted in accordance with the editorial rules of the ISO/IEC Directives, Part 2 (see www.iso.org/directives).

Attention is drawn to the possibility that some of the elements of this document may be the subject of patent rights. ISO shall not be held responsible for identifying any or all such patent rights. Details of any patent rights identified during the development of the document will be in the Introduction and/or on the ISO list of patent declarations received (see www.iso.org/patents).

Any trade name used in this document is information given for the convenience of users and does not constitute an endorsement.

For an explanation of the voluntary nature of standards, the meaning of ISO specific terms and expressions related to conformity assessment, as well as information about ISO's adherence to the World Trade Organization (WTO) principles in the Technical Barriers to Trade (TBT) see www.iso.org/iso/foreword.html.

This document was prepared by Technical Committee ISO/TC 172, *Optics and photonics*, Subcommittee SC 1, *Fundamental standards*.

This third edition cancels and replaces the second edition (ISO 10110-14:2007), which has been technically revised. The main changes compared to the previous edition are as follows:

- this document has been adjusted to ISO 10110-5 which includes the use of general surfaces.
- a new subclause “Additional forms” has been added as 5.2.2, which includes “PV and robust PV wavefront deviation” and “Wavefront deviation described by Zernike coefficients”.
- examples have been added in [Clause 6](#).
- subclause 4.5 has been deleted.

A list of all parts in the ISO 10110 series can be found on the ISO website.

Any feedback or questions on this document should be directed to the user's national standards body. A complete listing of these bodies can be found at www.iso.org/members.html.

Introduction

This document makes it possible to specify a functional tolerance for the performance (expressed as single-pass wavefront deformation) of an optical system, which may have optical power or contain powered optical elements. This tolerance therefore includes the effect of surface form deformations, inhomogeneities, and possible interactions among the various individual errors.

Optical elements are often tested in a “double-pass” configuration, in which the wavefront passes through or, in the case of reflective optics, reflects from the element under test twice, as shown in ISO/TR 14999-1:2005, Figure 18.

iTeh STANDARD PREVIEW (standards.iteh.ai)

[ISO 10110-14:2018](https://standards.iteh.ai/catalog/standards/sist/1ce49626-f1a6-4a39-bca0-832f29633d1d/iso-10110-14-2018)

<https://standards.iteh.ai/catalog/standards/sist/1ce49626-f1a6-4a39-bca0-832f29633d1d/iso-10110-14-2018>

iTeh STANDARD PREVIEW
(standards.iteh.ai)

ISO 10110-14:2018

<https://standards.iteh.ai/catalog/standards/sist/1ce49626-f1a6-4a39-bca0-832f29633d1d/iso-10110-14-2018>

Optics and photonics — Preparation of drawings for optical elements and systems —

Part 14: Wavefront deformation tolerance

1 Scope

This document specifies rules for the indication of the permissible deformation of a wavefront transmitted through or, in the case of reflective optics, reflected from an optical element or assembly in the ISO 10110 series, which standardizes drawing indications for optical elements and systems.

This document is also applicable when using optical systems with general surfaces (ISO 10110-19).

The deformation of the wavefront refers to its departure from the desired shape. The tilt of the wavefront with respect to a given reference surface is excluded from this document.

There is no requirement that a tolerance for wavefront deformation is indicated.

2 Normative references

The following documents are referred to in the text in such a way that some or all of their content constitutes requirements of this document. For dated references, only the edition cited applies. For undated references, the latest edition of the referenced document (including any amendments) applies.

ISO 10110-1, *Optics and photonics — Preparation of drawings for optical elements and systems — Part 1: General*

ISO 14999-4, *Optics and photonics — Interferometric measurement of optical elements and optical systems — Part 4: Interpretation and evaluation of tolerances specified in ISO 10110*

3 Terms and definitions

For the purposes of this document, the terms and definitions given in ISO 14999-4 apply.

ISO and IEC maintain terminological databases for use in standardization at the following addresses:

- ISO Online browsing platform: available at <https://www.iso.org/obp>
- IEC Electropedia: available at <http://www.electropedia.org/>

NOTE ISO 14999-4 provides the definitions for all the deformation functions.

4 Specification of tolerances for wavefront deformation

4.1 General

It should be noted that it is possible to specify a tolerance on the wavefront deformation only - without specifying tolerances on the individual surfaces. In this case, the manufacturer has to ensure that the wavefront satisfies the specified tolerance. However, the manufacturer is not bound by tolerances on the form of the individual surfaces of the element or system. The manufacturer is free, for instance, to allow the surface form deformations to be large provided they cancel each other.

It is also possible to supply a tolerance for the wavefront deformation, according to this document, in addition to tolerances on the form of the individual surfaces and/or inhomogeneity (according to ISO 10110-5 and ISO 10110-18, respectively). In this case, the manufacturer has to ensure that all of the individual tolerances (surface form tolerances and material imperfections) are upheld, as well as ensuring that the wavefront is of the specified quality.

In the case of double-pass testing, the additional wavefront deformation caused by the second transmission through the element has to be accounted for when comparing the measurement results with the specified tolerances. If the wavefront is not severely deformed by passing once through the element under test, and reflects from a high quality mirror, so that it returns through the identical portion of the test element to the interferometer, then the observed deformation of the wavefront is twice the (single-pass) wavefront deformation (defined in ISO 14999-4). That is, the wavefront deformation is one-half the observed wavefront deformation.

If the wavefront is severely deformed by the element under test, then the individual rays do not pass through the same positions in the element under test on their return path, and the wavefront deformation is not exactly twice that of the single path case.

The given wavefront deformation is only valid at the specified wavelength.

The tolerances for wavefront deformation are indicated by specifying the maximum permissible values of the power deviation, irregularity, and/or rotationally invariant irregularity. In addition, tolerances for three root-mean-square measures of wavefront deformation (rms total, rms irregularity and rms rotationally varying irregularity) may be specified. See ISO 14999-4 for definitions.

NOTE 1 The power deviation is meaningful only when the location of the image is specified. If the location of the image is unspecified, the power deviation is defined to be zero.

NOTE 2 Methods for determining the amount of power deviation, irregularity and rotationally invariant irregularity of a wavefront are given in ISO 14999-4.

It is not necessary that tolerances be specified for all types of wavefront deformation.

There is no requirement that a tolerance for wavefront deformation be indicated. If such a tolerance is specified, it does not take precedence over a surface form tolerance according to ISO 10110-5. If tolerances for both the surface form and the wavefront deformation are given, they are both to be upheld.

4.2 Units

The maximum permissible values for power deviation, irregularity, rotationally invariant irregularity and, if applicable, any target aberrations should be specified in units of nanometres. If wavelengths are to be used, the wavelength shall also be indicated on the drawing.

NOTE 1 These quantities are defined with reference to a wavefront passing once through the element or system under test (single-pass).

If a specification is to be given for one or more rms wavefront deformation types, the specification shall also be in units of nanometres or wavelengths (single-pass, see NOTE 1).

NOTE 2 One “wave” is $1 \times$ the wavelength (in nanometres) in which the wavefront deformation is specified.

NOTE 3 The specification of a tolerance for an rms deformation type requires that the optical system be analysed digitally.

The terminology of interferometry employing the unit “waves” is widely used for the specification of tolerances. However, the usage of non-interferometric methods for testing of optical parts has recently become more important. Therefore, unlike in the earlier versions of this document, “nanometres” is now the preferred standard unit to express wavefront deviations. The use of waves is still permitted given that the reference wavelength is explicitly stated.

4.3 Wavelength

If wave units are to be used, the wavelength shall also be indicated on the drawing in order to reduce confusion. If different wavelengths are used for measuring, separately calculated wavefront deformations are needed and can be provided as alternatives.

4.4 Target aberrations

Frequently, the nominal theoretical wavefront is spherical or planar. In some cases, to allow for the presence of small amounts of residual aberration in the design of an optical system, non-zero target values may be specified for polynomial aberration types.

5 Indication in drawings

5.1 General

The location of the stop surface or pupil shall be indicated according to ISO 10110-1. See [Figure 2](#).

The tolerance for wavefront deformation shall be indicated at the optical axis by a code number and the tolerances for power deviation, irregularity, rotationally invariant irregularity and rms deformation types shall be indicated as appropriate (see [5.2](#)).

Wavefront deformation should be specified in nanometres. However if wave units are to be used, the wavelength shall also be indicated. All quantities shall have their units specified. If no unit is indicated then wavelength units are implied.

No provision is given for the specification of a PV-tolerance for the total wavefront deformation (that is, including both the power deviation and the irregularity). If such a specification is necessary, this information shall be given in a note on the drawing for example: "Total wavefront deformation shall not exceed 150 nm" or "Total wavefront deformation shall not exceed 0,25 waves".

NOTE Such a specification might, for example, be useful for optical elements to be used in interferometers.

See [Clause 6](#) for examples of tolerance indications.

5.2 Code number

5.2.1 Basic forms

The indication shall consist of one basic form and may be supplemented by additional forms. Multiple forms shall be separated by a semicolon. The code number for wavefront deformation is 13/.

$$13/A(B/C); \lambda = E$$

or

$$13/A(B/C) \text{ RMS}_x < D; \lambda = E$$

(where x is one of the letters t, i or a; see ISO 14999-4).

or

$$13/\text{RMS}_x < D; \lambda = E$$

(where x is one of the letters t, i or a; see ISO 14999-4).

NOTE 1 In former editions 13/— $\text{RMS}_x < D; \lambda = E$ was used.

or

13/ AX ; AY (B/CX ; CY)

The quantity A is either:

- a) the maximum permissible (single-pass peak-to-valley value) power deviation $PV(f_{WS})$ as defined in ISO 14999-4 expressed in nanometres, micrometres, or waves, or
- b) a dash (—) indicating that no explicit tolerance for power deviation is given.

The quantities AX , AY are either

- a) the maximum permissible power deviation (single pass peak-to-valley value) $PV(f_{WC,x})$ and $PV(f_{WC,y})$ for cylindric and similar wavefront deformation defined in ISO 14999-4, expressed in nanometers, micrometers, or waves, or
- b) a dash (—) indicating that no explicit tolerance for power deviation is given.

The quantity B is either:

- a) the maximum permissible value (single-pass peak-to-valley value) $PV(f_{WI})$ of irregularity,
- b) the maximum permissible value (single pass peak-to-valley value) $PV(f_{WI,CY})$ of irregularity for cylindric and similar wavefront deformation as defined in ISO 14999-4, expressed in nanometers, micrometers, or waves when AX and/or AY are used, or
- c) a dash (—) indicating that no explicit tolerance for irregularity is given.

The quantity C is:

- a) the maximum permissible value of the (single-pass peak-to-valley value) $PV(f_{WRI})$ of rotationally invariant irregularity. If no tolerance is given, the slash (/) is replaced by the final parenthesis, i.e. 13/ $A(B)$, or
- b) a dash (—) indicating that no explicit rotationally invariant irregularity tolerance is given.

The quantities CX and CY are

- a) the maximum permissible value (peak-to-valley) $PV(f_{WTI,x})$, $PV(f_{WTI,y})$ of translationally invariant irregularity for cylindric and similar wavefront deformation, expressed in nanometres, micrometers or waves, as defined in ISO 14999-4. CX and CY are used for the symmetry specification across the x and y axis; or
- b) a dash (—) indicating that no explicit translationally invariant irregularity tolerance for both or one of them is given.

If no tolerance is given, the slash (/) is replaced by the closing parenthesis, i.e. 13/ AX ; $AY(B)$.

The quantity D is the maximum permissible value of the rms-quantity of the type specified by x , where x is one of the letters t , i or a . These deviations are defined

- a) for rotationally symmetric wavefront deformation rms (f_{WD}) the rms total for t , rms (f_{WI}) the rms irregularity for i and rms (f_{WRV}) the rms rotationally varying (asymmetric) irregularity for a as defined in ISO 14999-4 or
- b) for cylindric and similar wavefront deformation in rms ($f_{WD,CY}$) the rms total for t , rms ($f_{WI,CY}$) the rms irregularity for i and rms (f_{WTV}) the rms translationally varying (asymmetric) irregularity for a as defined in ISO 14999-4.

The specification of more than one type of rms-deviation is allowed. These specifications shall be separated by a semicolon, as shown in [Clause 6](#), Examples 7a and 7b.

The quantity E is the wavelength in which the wavefront deformation is specified.

NOTE 2 The values A and C are best used for types of rotationally invariant or similar wavefront deformations. The values AX , AY as well as CX and CY are best used for types of cylindric, toric or similar wavefront deformations.

If no tolerance is given for any of the deformation types, then A , B , C , $RMSx < D$ the divisor line (/) and the parenthesis are replaced by a single dash (—), i.e. 13/—.

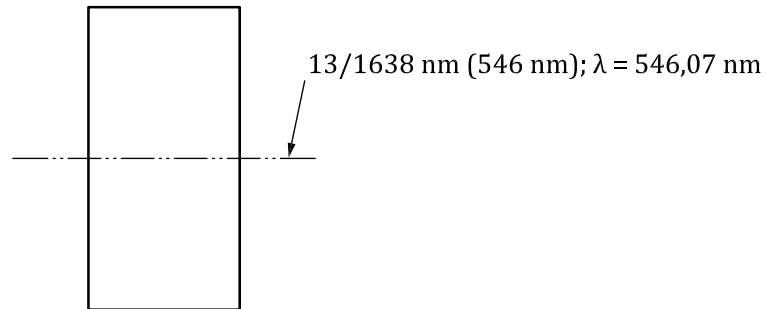

Figure 1 — Example of an indication of a tolerance for wavefront deformation, with planar illumination

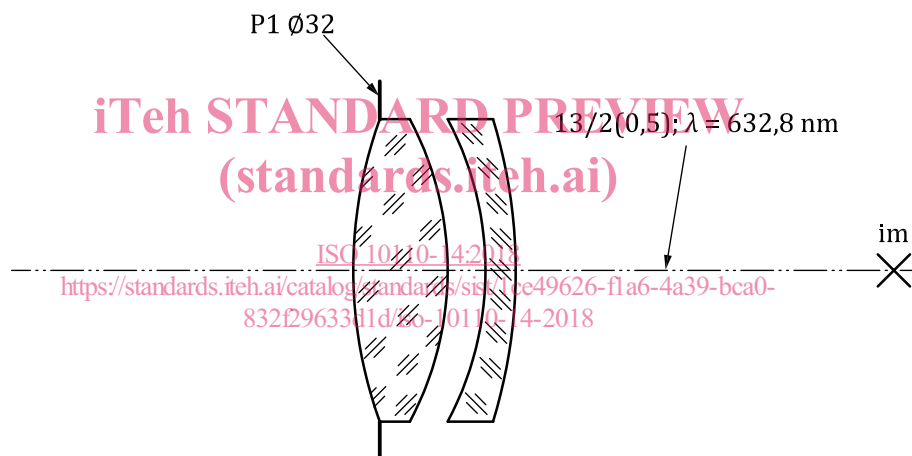

Figure 2 — Example of an indication of a tolerance for wavefront deformation, with planar illumination

5.2.2 Additional forms

5.2.2.1 PV and robust PV wavefront deviation

$PV(F)$

and

$PVr(G)$

The quantity F is the maximum permissible peak-to-valley value of the total wavefront deviation $PV(f_{WD})$ as defined in ISO 14999-4, expressed in nanometres, micrometres, or waves.

The quantity G is the maximum permissible robust peak-to-valley value of the total wavefront deviation $PVr(f_{WD})$ as defined in ISO 14999-4, expressed in nanometres, micrometres, or waves.