



Designation: F1148 – 09

Standard Consumer Safety Performance Specification for Home Playground Equipment¹

This standard is issued under the fixed designation F1148; the number immediately following the designation indicates the year of original adoption or, in the case of revision, the year of last revision. A number in parentheses indicates the year of last reapproval. A superscript epsilon (ϵ) indicates an editorial change since the last revision or reapproval.

1. Scope

1.1 This consumer safety specification provides safety requirements for various types of home playground equipment intended for use by children aged from over eighteen months through 10 years. It further provides such requirements for swings intended specifically for toddlers. Different age limits for various requirements are found in this specification. These limits reflect the nature of the hazards and the expected mental or physical ability, or both, of the child to cope with the hazards.

1.2 Home playground equipment is defined as any product in which the support structure remains stationary while the activity is taking place and is intended for a child to perform any of the following activities: climbing, swinging, sliding, rocking, spinning, crawling, or creeping, or combination thereof. Fitness equipment is specifically excluded unless attached to the play equipment. This specification is not intended to apply to juvenile care products such as, but not limited to, infant swings, playpens/enclosures, beds, or furniture (including outdoor furniture, such as picnic tables, cradle rockers, activity centers being used as walker substitutes, bouncers, jumpers, infant carriers, and products specifically designed for therapeutic use). This specification is not intended to apply to equipment to be used in places of public assembly such as schools, nurseries, day-care centers, and parks. Equipment intended to be in child-care centers in private homes is not exempt from the requirements of this specification. Such centers are defined as situations in which the child-care provider does not care for more than six children under the age of ten that are not residing in the household of the caregiver, and the total number of children under the age of ten does not exceed ten, including the caregiver's own children. Electrically operated constant air inflatable devices are exempted from the requirements of this specification.

1.3 Methods of identifying products that comply with this consumer safety specification are given. The illustrations of home playground equipment shown in Figs. A1.1-A1.4 are for informational purposes only and are not intended to limit or

endorse certain types of playground equipment or equipment features. These illustrations are not intended to limit the variety or various combinations of equipment that are covered by this consumer safety specification.

1.4 The purpose of this specification is to reduce the likelihood of life-threatening or debilitating injuries.

1.5 If toy accessories or toy chests are attached to home playground equipment, they are applicable to this consumer safety specification and to any other applicable safety standards.

NOTE 1—See **Annex A1** for figures referenced throughout this consumer safety performance specification.

1.6 The values stated in inch-pound units are to be regarded as standard. The values given in parentheses are mathematical conversions to SI units that are provided for information only and are not considered standard.

2. Referenced Documents

2.1 *ASTM Standards*:²

D2240 Test Method for Rubber Property—Durometer Hardness

F1292 Specification for Impact Attenuation of Surfacing Materials Within the Use Zone of Playground Equipment

2.2 *Federal Standards*:

16 CFR 1303 Ban of Lead-Containing Paint and Certain Consumer Products Bearing Lead-Containing Paint³

16 CFR 1500 Hazardous Substances Act Regulations, including sections:³

1500.48 Technical Requirements for Determining a Sharp Point in Toys and Other Articles Intended for Use by Children Under 8 Years of Age

1500.49 Technical Requirements for Determining a Sharp Metal or Glass Edge in Toys and Other Articles Intended for Use by Children Under 8 Years of Age

1500.52 and **.53** Test Methods for Simulating Use and Abuse of Toys and Other Articles Intended for Use by Children

¹ This specification is under the jurisdiction of ASTM Committee F15 on Consumer Products and is the direct responsibility of Subcommittee F15.09 on Home Playground Equipment.

Current edition approved June 1, 2009. Published July 2009. Originally approved in 1988. Last previous edition approved in 2008 as F1148 – 08. DOI: 10.1520/F1148-09.

² For referenced ASTM standards, visit the ASTM website, www.astm.org, or contact ASTM Customer Service at service@astm.org. For *Annual Book of ASTM Standards* volume information, refer to the standard's Document Summary page on the ASTM website.

³ Available from Consumer Product Safety Commission, Washington, DC 20207.

16 CFR 1501 Method for Identifying Toys and Other Articles Intended for Use by Children Under 3 Years of Age Which Present Choking, Aspiration, or Ingestion Hazards Because of Small Parts³

Federal Motor Vehicle Safety Standard No. 218⁴

2.3 *Society for Automotive Engineers Recommended Practice*:⁵

SAE J211 Instrumentation for Barrier Collision

3. Terminology

3.1 *Definitions of Terms Specific to This Standard:*

3.1.1 *anchors*—accessories used to minimize possible tipping of the playground equipment, or lifting of the support legs.

3.1.2 *continuous surface*—a surface smooth to the extent that no hazard such as a catch point for clothing or sharp edge/sharp point is created.

3.1.3 *edge, sharp*⁶—an edge that can cut a child's skin during use of the playground equipment. Such an edge is judged as sharp pursuant to the provisions of 16 CFR Section **1500.49**.

3.1.4 *guardrail*—a guardrail is a device around an elevated surface that is intended to prevent inadvertent falls from the elevated surface.

3.1.5 *hand grasping component*—a component intended to be grasped by the hand to steady a user (such as a handrail).

3.1.6 *hand gripping component*—a component intended to be gripped by the hand to support the full body weight (such as a rung of a horizontal ladder or trapeze bar).

3.1.7 *handrail*—the structural member that helps a child steady himself. As used in this consumer safety performance specification, a handrail is the structural member at the top of a slide that helps a child steady himself while he sits down (see Fig. A1.1).

3.1.8 *platform*—any elevated horizontal surface intended to be used by children as a place for play or as a transition between components. Slide transition areas <200 in.² are not considered platforms.

3.1.9 *point, sharp*⁷—a point that can puncture or lacerate a child's skin during use of the playground equipment. Such a point is judged as potentially sharp pursuant to the provisions of 16 CFR Section **1500.48**.

3.1.10 *protective barrier*—an enclosure around an elevated surface that is intended to prevent both inadvertent and deliberate attempts to pass through the device.

⁴ Available from National Highway Traffic Safety Administration, 400 7th St. SW, Washington, DC 20590.

⁵ Available from the Society of Automotive Engineers, 400 Commonwealth Drive, Warrendale, PA 15096.

⁶ A sharp edge tester suitable for conducting tests in accordance with the Federal regulation at 16 CFR Section **1500.49** is available from U.S. Testing Co., Inc., 1415 Park Avenue, Hoboken, NJ 07030. Engineering drawings from which a sharp edge tester may be fabricated are available from the Office of the Secretary, Consumer Product Safety Commission, Washington, DC 20207.

⁷ A sharp point tester for conducting tests in accordance with the Federal regulation at 16 CFR Section **1500.48** is available from U.S. Testing Co., Inc., 1415 Park Avenue, Hoboken, NJ 07030. An engineering drawing from which a sharp point tester may be fabricated is available from the Office of the Secretary, Consumer Products Safety Commission, Washington, DC 20207.

3.1.11 *rung*—a cross-piece in a ladder or other climbing equipment used for supporting the user's feet or grasping by the user's hands, or both. A rung must comply with **4.6** for hand-gripping components.

3.1.12 *small part*—a component that may become detached during use of the playground equipment and presents a choking, aspiration, or ingestion hazard to a child. Such a component is determined to be a hazard pursuant to the provisions of **16 CFR 1501**.

3.1.13 *toddler swing*—a fully enclosed single occupant swing intended for young children who can sit upright unaided. A seat is considered fully enclosed when a containment system is employed that supports the child on all sides and in between the legs (see Fig. A1.33).

3.1.14 *toy accessory*—an article that provides certain play value separate from, but attached to or sold with, home playground equipment intended for play-time use by a child. Such articles include miniature imitations for play use of objects intended primarily for a specific purpose (for example, a toy telephone or a toy gas pump).

3.1.15 *turnbar*—the horizontal bar between the supporting legs of a swing set, such as the one shown in Fig. A1.1.

3.1.16 *use zone*—the area beneath and immediately adjacent to a play structure or equipment that is designated for unrestricted circulation around the equipment, and on whose surface it is predicted that a user would land when falling or exiting the equipment.

4. Performance Requirements

4.1 *General*—Home playground equipment shall be manufactured and constructed only of materials that have a demonstrated durability in an outdoor setting. Any new materials shall be documented or tested accordingly for durability by the playground equipment manufacturer or their agent.

4.1.1 Metals subject to structural degradation such as by rust or corrosion shall be painted, galvanized, or otherwise treated. Woods shall be naturally rot- and insect-resistant or treated to avoid such deterioration. Creosote, pentachlorophenol, tributyl tin oxide, and surface coatings that contain pesticides shall not be used for playground equipment. Wood treaters and playground equipment manufacturers shall practice technologies and procedures that minimize the level of dislodgeable toxin. Plastics and other materials that experience ultraviolet (UV) degradation shall be stabilized against ultraviolet light.

4.1.2 Regardless of the material or the treatment process, the manufacturer shall ensure that the users of the playground equipment cannot ingest, inhale, or absorb any potential hazardous amounts of substances through body surfaces as a result of contact with the equipment.

4.1.3 *Lead in Paint*—All paints and finishes used on playground equipment shall be in accordance with **16 CFR 1303**.

4.1.4 *Edges, Points, and Surfaces*—Following assembly of the unit in accordance with the instructions to be provided to the consumer, there shall be no sharp edges, points, or surfaces on any portion of the home playground equipment capable of inflicting a cut on a child.

4.1.5 *Open Tubing*—All open tubing ends that are not resting on the ground, or otherwise covered, shall be provided

with caps or plugs that have a smooth finish and are tight-fitting. They shall be subjected to a torque of 4 lbf-in. (0.45 N-m) and a force of 15-lbf (67-N) when tested in accordance with Title 16 CFR Section 1500.53(e and f).

4.1.6 Pinch, Crush, and Shear Points—There shall be no pinch, crush, or shear points caused by junctures of two components moving relative to one another that could cause a contusion, laceration, abrasion, amputation, or fracture. A pinch, crush, or shear point is any point that allows a $\frac{3}{16}$ in. (5 mm) diameter neoprene rod to enter at one or more positions and entraps at one or more positions a $\frac{1}{2}$ -in. (13-mm) diameter neoprene rod. Entrapment shall mean that a force of more than 2 lbf (9 N) is required to pull out the rod. The neoprene rods shall have a hardness reading between 50 and 60 as determined by a Type A durometer in accordance with Test Method D2240.

4.1.7 Acute Angles—There shall be no acute angles, or group of acute angles, formed by two or more members in which the legs point upward from the apex so that the configuration approximates a “V” with an interior angle less than 55° (0.96 rad).

4.1.7.1 Exemptions to 4.1.7:

(1) *Inverted Angle or “V” Condition*—Those “V’s” that are inverted. A “V” is considered inverted if the lower adjacent leg forming the “V” is horizontal or slopes downward from the apex (see Fig. A1.5).

(2) *Filled Apex Condition*—“V” angles less than 55° where the apex of the angle is filled to the point that will not allow the head probe to contact both surfaces of the angle simultaneously (see Fig. A1.5). The angle shall be covered with a shield that is made of a rigid material. The shield shall be capable of withstanding impact of at least 20 ft-lbf (27 J) imparted to a spot within 1 in. (25 mm) of the geometric center of the shield by a 5-in. (127-mm) diameter steel ball. The shield shall be tested while secured to the members of the playground equipment by the hardware provided. During the test, the equipment or portions thereof, if required, shall be oriented so that the surface of the shield is horizontal.

(3) *Rope, Chain and Cable*—“V” angles less than 55° where the apex of the angle is formed by an inclined or vertical climbing surface and a rope, chain or cable. To be exempt, the point of the formed “V” angle must be no greater than 1.5 in. (38 mm) above the protective surfacing. See Fig. A1.6.

4.1.8 Spacing Between Adjacent Swing Elements:

4.1.8.1 Swing sets containing adjacent swing elements shall be designed so that there is a minimum of 8 in. (205 mm) separating elements that are capable of limited lateral motion (where two or more chains, ropes, or poles are used for suspension). The outermost lateral extremities of the swinging elements shall govern the measurement of separation; an example is illustrated by Dimension A in Fig. A1.7 and Fig. A1.8.

4.1.8.2 Swing elements that are intended to have unlimited lateral motion such as, but not limited to, a rotating swing or disc swing shall not occupy a swing bay with any other swinging element. There shall be a minimum separation of 15 in. (381 mm) between the outermost extremity of the swinging element and the support structure, as measured in a vertical

plane from the outermost extremity from the top bar to the protective surface (see Fig. A1.8).

4.1.8.3 Lateral Stability of Swing Elements—All to-fro swings, belt type or rigid, shall have a minimum distance between suspension points as calculated from the following formula:

$$A = 0.04(H) + B \quad (1)$$

where:

A = the center to center distance between uppermost suspension points of the swing assembly,

B = the center to center distance between the swing seat attachment points (in the case of flexible seats, place the weighted test fixture as described in Fig. A1.9 in the seat before measuring dimension B), and

H = the distance between the uppermost suspension point and the protective surfacing.

4.1.9 Spacing Between Swing Elements and Stationary Frame Members:

4.1.9.1 Occupant Enclosed—Elements with two or more laterally spaced supports where supports are on both sides of the occupant (for example, suspended chain or rope swings and tubularly suspended lawn swings). Minimum spacing between the outer extremity of the swing element and stationary members shall be 7 in. (180 mm) when measured at a height of 28 in. (710 mm) above the seating surface (see Dimension C in Fig. A1.7 and Fig. A1.8).

NOTE 2—Twenty-eight inches (710 mm) is the approximate sitting height of a ten-year-old.

4.1.9.2 Occupant-Exposed Rides—Examples are: the pendulum seesaw, horse rides, and others where the suspension system is in line with the occupant. Minimum spacing from stationary members shall be 16 in. (405 mm) as measured from the center of the seating surface at a height of 22 in. (560 mm) above the seating surface (see Dimension D in Fig. A1.7 and Fig. A1.8).

NOTE 3—Sixteen inches (405 mm) and 22 in. (560 mm) equate to the clearance required for a ten-year-old when leaning to the side at an angle of 30° (0.52 rad).

4.1.9.3 Occupant-Exposed Single Suspension— Examples are: suspended ropes or poles. Minimum spacing from stationary members shall be 15 in. (380 mm) to a height of 53 in. (1350 mm) above ground level (see Dimension E in Fig. A1.7 and Fig. A1.8).

NOTE 4—Fifty-three inches (1350 mm) is the approximate standing height of a ten-year-old.

4.1.9.4 Free Swinging Rings—The distance between the protective surface and the lowest portion of the ring may not be less than 53 in. (1350 mm). The distance from the outermost extremity of the ring to an adjacent swing or support structure shall be a minimum of 8 in. (205 mm) (see Fig. A1.8).

4.1.10 Hardware:

4.1.10.1 Upon final assembly, bolt ends shall not protrude beyond the nuts more than the diameter of the bolt when the nuts are tightened to a torque between 20 and 25 lbf-in. (2.3 and 2.8 N-m)).

4.1.10.2 Threaded bolt ends that are recessed such that the end of the bolt lies at or below a surrounding surface located within 1 in. (25 mm) of the centerline of the bolt are exempt from the requirements of 4.1.10.1 (see Fig. A1.10). Recessed threaded bolt ends that are free from hazardous sharp edges and burrs are exempt from the requirements of 4.1.10.3.

NOTE 5—The surrounding surface shall be blended wherever possible to create smooth contours without abrupt changes in shape that could pose a potential impact hazard.

4.1.10.3 If the threaded ends of exposed bolts or rods protrude from adjacent surfaces in areas of normally expected play, or if the thread is not free of exposed hazardous sharp edges or burrs, or both, then the threaded ends shall be covered by smooth finish caps.

4.1.10.4 Any caps that are used shall be tight-fitting when installed in accordance with the manufacturer's instructions. They shall be subjected to a torque of 4 lbf·in. (0.45 N·m) and a tensile force of 15 lbf (67 N). These components shall comply with the requirements of 16 CFR 1500.48, 1500.49, 1500.53 (e and f), and 1501.

4.1.11 Lock washers, self-locking nuts, or other locking means shall be provided for all bolts.

4.1.12 *Hooks*—Open-ended hooks may be used for the uppermost suspension point of suspended elements provided that they have openings, or entry to an opening, in the area inside the boundaries represented by a line that is adjacent to the outer extremity of the uppermost portion of the hook, and parallel to the normal plane of suspension. Some examples of hooks that are acceptable and unacceptable are shown in Fig. A1.10.

4.1.12.1 Hooks used for attachment of rides, or swing elements at any point other than at the uppermost suspension point, shall be designed to allow full closure, or be otherwise protected (for example, protective coverings). A hook is considered closed when the gap or space cannot admit a 0.04-in. (1-mm) feeler gage.

4.1.13 *Guardrails and Protective Barriers*—Guardrails or protective barriers shall be provided on elevated surfaces such as platforms, landings, walkways, ramps and similar transitional play surfaces, in accordance with the following subsections. Guardrails and protective barriers shall be designed to discourage climbing and must have a top surface less than three inches wide or having greater than a 30 degree angle from horizontal.

4.1.13.1 Elevated surfaces less than or equal to 30 in. (76 cm) above the surfacing do not require guardrails. Guardrails shall be provided on elevated surfaces greater than 30 in. (76 cm) but less than or equal to 48 in. (122 cm) above the surfacing. Protective barriers shall be provided on elevated surfaces greater than 48 in. (122 cm) above the surfacing.

4.1.13.2 Guardrails shall completely surround the elevated surface except for entrance and exit openings necessary for each event. Guardrail overall height shall be 25 in. (63 cm) or more. The maximum vertical opening between the lowermost member of a guardrail and the elevated surface it surrounds shall be 24 in. (61 cm). Openings between guardrail members or between a guardrail and the elevated surface it surrounds shall conform to the recommendations addressing head and

neck entrapment. If the top surface of the guardrail creates a completely bounded opening which presents a head and neck entrapment hazard, it is permissible to lower the guardrail to below the 25 in. (63 cm) height requirement to eliminate the head and neck entrapment hazard (see example in Fig. A1.12).

4.1.13.3 Elevated surfaces that are greater than 48 in. (122 cm) above the surfacing but less than or equal to 72 in. (183 cm) above the surfacing shall have protective barriers at least 27 in. (69 cm) high. Elevated surfaces greater than 72 in. (183 cm) above the surfacing shall have protective barriers at least 33 in. high.

(1) Protective barriers shall completely surround the elevated surface except for entrance and exit openings necessary for each event. Protective barriers shall be designed to minimize the likelihood of climbing. Openings within barriers or between the platform surface and lower edge of protective barriers shall preclude passage of the torso probe (see Fig. A1.14).

4.1.14 *Head and Neck Entrapment*—Home playground equipment shall be designed and constructed so that when assembled any accessible opening shall meet the following performance requirements to reduce the risk of accidental head or neck entrapment by either a head first or feet first entry into the opening. Openings between the ground and the bottom edge of the equipment (such as rails, platforms, steps, etc.) are exempt from this requirement as illustrated in Fig. A1.13.

4.1.14.1 *Accessible Openings*—Any completely bounded opening that completely accepts the torso test probe. A completely bounded opening is accessible when a torso test probe may be inserted into the opening to a depth of 4 in. (100 mm) using the following test method (see Fig. A1.14).

(1) *Test Procedure and Performance Criteria for Completely Bounded Openings*—Place the torso probe in the opening, tapered end first, with the plane of its base parallel to the plane of the opening; rotate the probe while keeping its base parallel to the plane of the opening. If the base of the probe passes through the opening when it is rotated about its own axis in any orientation, place the head probe (see Fig. A1.15) in the opening, tapered end first, while its plane is parallel to the plane of the opening.

(2) An opening can pass this test when tested in accordance with 4.1.13.1(1) in one of two ways: (1) the opening does not admit the torso probe when it is rotated to any orientation about its own axis, or (2) the opening admits the torso probe and also admits the head probe.

(3) An opening fails the test under the following conditions: The opening admits the torso probe but does not admit the head probe.

4.1.14.2 Completely bounded openings that are accessible must also meet requirements for angles as outlined in 4.1.7.

4.1.14.3 *Nonrigid Completely Bounded Openings*—A nonrigid opening such as, but not limited to, flexible nets, tarps, and plastic enclosures, is considered accessible if a torso probe will penetrate the opening to a depth of 4 in. (100 mm) when tested in accordance with 4.1.14.1(1) (see Fig. A1.14). Flexible restraining systems on toddler swings are exempt from this requirement unless they form leg openings.

TABLE 1 Swing Hanger Arc and Test Weight

Swing Type	θ_o , degrees	Test Weight, lb (kg)
Single-occupancy swing (two hangers)	90	80 (37)
Multiple-occupancy exposed swing (two hangers, two occupants)	60	130 (60)
Multiple-occupancy enclosed swing (four hangers, two occupants)	45	60 (27)
Multiple-occupancy enclosed swing (four hangers, four occupants)	45	120 (54)

(1) Test Procedure for Entrapment in Nonrigid Openings—

Place the torso probe in the opening, tapered end first, with the plane of its base parallel to the plane of the opening; rotate the probe while keeping its base parallel to the plane of the opening; apply 50 lbf (222 N) while attempting to push the probe through the opening. If the base of the probe passes through the opening when it is rotated about its own axis in any orientation and 50 lbf (222 N) is applied, place the head probe in the opening, tapered end first, while its plane is parallel to the plane of the opening and 50 lbf (222 N) is applied.

(2) A nonrigid opening can pass the test when tested in accordance with 4.1.14.3(1) in one of two ways: (1) the opening does not allow the torso probe to be inserted so deep that the opening admits the base of the probe when it is rotated to any orientation about its own axis, or (2) the opening allows full passage of the torso probe and also allows the head probe to pass completely through.

(3) A nonrigid opening fails the test under the following conditions: the opening allows full passage of the torso probe but does not admit the head probe.

4.1.15 *Holes and Slots*—If a circular hole or slot in any rigid material with a thickness $< \frac{3}{8}$ in. (10 mm) is accessible and can admit a $\frac{1}{4}$ -in. (6-mm) diameter rod to a depth of $\frac{3}{8}$ in. (10 mm) or greater, it shall also admit a $\frac{1}{2}$ -in. (13-mm) diameter rod. Chains are exempt except as described in 4.2.6.2.

4.2 *Swings:*

4.2.1 *Hangers*—All swing elements shall have hanger arrangements whose durability shall be determined by either of the following dynamic cycling tests. At the completion of the test there shall be no loosening or structural failure of the hanger.

4.2.1.1 Each type of swing element shall be attached to its support member in accordance with the installation instructions and mounted in a suitable test fixture. Flexible components of the swing element may be replaced by rigid components of at least the same size and weight as long as the alternate components do not affect the swing element's moving parts. The appropriate test weight shall be secured to each occupant position to be tested. This suspended unit shall then be oscillated through an arc with an included angle as specified in Table 1 for a total of 180 000 cycles (forward and backward).

4.2.1.2 As an alternative to the test in 4.2.1.1, swing hangers may be tested individually in a laboratory test fixture as follows: Secure the hanger to a portion of its support member in accordance with the manufacturer's installation instructions. Install the support member and hanger in the test fixture shown in Fig. A1.16, ensuring that the pivot axis of the test fixture and the pivot point of the hanger are aligned. In accordance with Table 1, attach the appropriate test weight to the hanger and

oscillate the hanger support member 180 000 cycles (forward and backward) through the appropriate arc.

4.2.2 *Minimum Ground Clearance*—When the assembled swing set is installed according to the manufacturer's instructions, the minimum clearance between the ground surface and the underside of any suspended unit shall be 8 in. (200 mm).

4.2.3 *Single-Occupancy Swings*—Swings designed for individual use, when tested in accordance with the impact test method in Appendix X1, shall not impart a peak acceleration in excess of 100 g (980 m/s²) to the test headform.

NOTE 6—Rides with straddle-type seats (such as a horse) are exempt from this requirement.

4.2.4 *Multiple-Occupancy Swings*—These swings shall be provided with platforms or footrests and seats meeting the criteria given in 4.2.4.1-4.2.4.4.

4.2.4.1 Seats intended for individual or dual passengers that include a backrest shall be designed so that any opening between the seat and the backrest shall prevent entry of the test fixture (see Fig. A1.17 and Fig. A1.18) when it is located at any point in the opening and a force of 45 lb (200 N) is applied to the fixture in a direction perpendicular to the entrance plane of the opening. The force shall be applied gradually and maintained for 5 min.

4.2.4.2 The platform or footrest shall extend no less than 1 in. (25 mm) behind the forward leading edge of the seat (see Dimension A, Fig. A1.17). This dimension shall be measured horizontally with the swing in its at-rest position. The space between any slats in the platform shall be no greater than $1\frac{1}{2}$ in. (38 mm).

4.2.4.3 The area of the platform that extends beyond the vertical supports of the swing shall be angled upwards not less than 30° from the horizontal (see Angle C, Fig. A1.17).

4.2.4.4 The bottom edge of the seat skirt shall not be more than 10 in. (250 mm) above the top surface of the platform or footrest when the swing is in its at-rest position (see Dimension B, Fig. A1.17).

4.2.5 *Pendulum See-Saws*—Pendulum seesaws shall be provided with footrests. There shall be no openings with internal dimensions of which both the length and width are greater than 3.5 in. (89 mm) and less than 9 in. (229 mm). The spacing between the two support bars shall not decrease toward the seat supports. In the case of a pendulum seesaw designed with formed handles providing a greater opening, the minimum spacing below the formed handles shall be greater than 9 in. (229 mm).

4.2.6 *Toddler Swings:*

4.2.6.1 *Restraining System*—Toddler swings shall have a child restraining system. Fully enclosed flexible bucket seats are exempt from this requirement.

(1) Toddler swings shall be equipped with a crotch restraint. A crotch restraint designed to work with a lap belt shall be designed such that its use is mandatory when the restraint system is in use.

4.2.6.2 *Chains*—Chains on swing seats that support the weight of a child, intended for children 36 months or less in age, shall be shielded if the chain is accessible and if a 0.19 in. (4.8 mm) diameter rod can be inserted between two links, as in

Fig. A1.34, with the chain in a slack configuration. A chain is considered accessible within 33 in. (840 mm) of the top of seating surface.

NOTE 7—The 33 in. is based on a Netherlands anthropometry study showing the seated vertical reach height of a 97 % 3-year-old male to be 32.7 in.

4.2.6.3 Toddler Swing Stability—Toddler swings shall remain stable when tested in accordance with the stability test method in **4.2.6.5**. A swing is considered unstable and fails this requirement if, during any of the six swing attempts, the pendulum test apparatus (see **Fig. A1.35**) tips or falls forward or backward and causes the horizontal reference line of the toddler swing to hang at an angle greater than 30° from its original position (see **Fig. A1.36**).

4.2.6.4 Toddler Swing Stability Test Setup:

(1) Toddler swings shall be tested for stability utilizing a pendulum test apparatus constructed in accordance with the dimensions and materials specified in **Fig. A1.35**. The pendulum test apparatus consists of a 10 lb (4.5 kg) barbell weight at the top of a freely pivoting bar and a 10 lb (4.5 kg) barbell weight affixed to the bottom of the test apparatus. The barbell weights shall have a maximum diameter of 8.25 in. (210 mm). The total weight of the pendulum test apparatus shall not exceed 24.0 lb (10.9 kg).

(2) Suspend the toddler swing seat in accordance with the manufacturer's instructions. If the swing height is adjustable, perform the test at both the highest and lowest settings. With the swing at rest, establish a horizontal reference line on the swing seat.

(3) Secure the complete pendulum test apparatus within 0.5 in. (13 mm) of the geometric center of the swing seating surface with the direction of travel of the pendulum arm the same as the swing direction.

(4) If the seating area of the toddler swing is made of a flexible material, additional bracing material may be added to the exterior bottom of the swing seat to aid in securing the pendulum test apparatus. Care should be taken to assure the additional bracing material does not influence the test results.

(5) The center of gravity (cg) of the top weight of the pendulum test apparatus shall be at a height of 16 in. (410 mm) from the top of the seating surface when the pivot arm is positioned vertically.

NOTE 8—The 16 in. height is based on field testing of swings that were recalled because of tipover and swings that have performed without tipping over.

4.2.6.5 Toddler Swing Stability Test Method:

(1) While holding the pendulum test apparatus to the rear of the seat, raise the swing seat in the rear direction to an angle of 60° +5/-0 as measured from vertical to a line that connects the swing hanger pivot point with the geometric center of the seating surface.

(2) Simultaneously release the swing and pendulum test apparatus and allow it to swing freely until the swing arc is within 15° from vertical in either direction. At this point, stop the swinging motion by slowly returning the swing to its at-rest condition while being careful not to disturb the position of the pendulum test apparatus. Measure the angle of the reference line on the swing seat from the horizontal.

(3) Perform steps 1 and 2 three times.

(4) Repeat steps 1 through 3, except that the pendulum test apparatus shall be held in the forward direction.

(5) If after any of the six swing attempts the angle of the swing in its at-rest condition exceeds 30°, as noted in **4.2.6.3**, the swing is considered unstable and fails.

4.3 Slides:

4.3.1 Slide Requirements:

4.3.1.1 Slides shall be constructed in a manner that eliminates exposed vertical members or angular up-rights.

4.3.1.2 A handrail shall be provided on all sides of the transition area (except on entrance and exit areas) that meet the enclosed opening requirements of **4.1.13**. Slide transition areas larger than 200 in.² are considered platforms and shall comply with the requirements for guardrails and protective barriers found in **4.1.13**.

(1) All handrail bend radii shall be a minimum of 2 in. (50 mm).

4.3.1.3 The transition area at the top of a slide shall be at least 10 in. (250 mm) long and shall be at least as wide as the sliding surface.

4.3.1.4 With the exception of roller slides (see **4.3.3**), the inclined sliding surface and the exit surface shall be one continuous surface.

4.3.1.5 The slide shall have raised edges that project at least 1 in. (25 mm) above the slide surface when measured perpendicularly to that surface.

4.3.1.6 The slide shall have a reduced-gradient exit surface at least 6 in. (150 mm) in length; the reduced-gradient exit surface shall be at a minimum angle of 18° from the inclined sliding surface, and the exit surface shall be greater than 0°, but not more than 30° (0.52 rad), from horizontal.

(1) Slides having an entrance height of 4.5 ft (1.4 m) or less and having an inclined angle of 30° or less from the horizontal are not subject to the reduced gradient requirement.

4.3.1.7 The end of the slide shall be no more than 12 in. (300 mm) off the ground as measured from the sliding surface.

4.3.1.8 The end of the exit surface on metal slides shall be formed through an arc of at least 170° (2.97 rad).

4.3.1.9 Slides exceeding 4.5 ft in height from platform to ground level shall have a side of not less than 2.5 in. (64 mm) above the slide bed commencing at a point on the slide 4.5 ft, as measured vertically, from the ground and extending to the top platform on the slide.

4.3.1.10 **Fig. A1.19** illustrates these requirements for slides.

4.3.1.11 Slide Chute/Bedway Clearance Zones—A clear area, free of equipment, shall surround the slide chute/bedway. This area is defined by **Fig. 1**. Portions of slides containing hoods or other devices to channel the user into a seated position, spiral slides and tube slides excepted. The clear area shall extend through the slide exit clearance zone as defined in **4.14.3**.

(1) Spiral slides with open chutes shall maintain a clear area 20 in. (508 mm) wide, when measured from the inside face of the sidewall along the outer edge of the slide for the entire length of the slide.

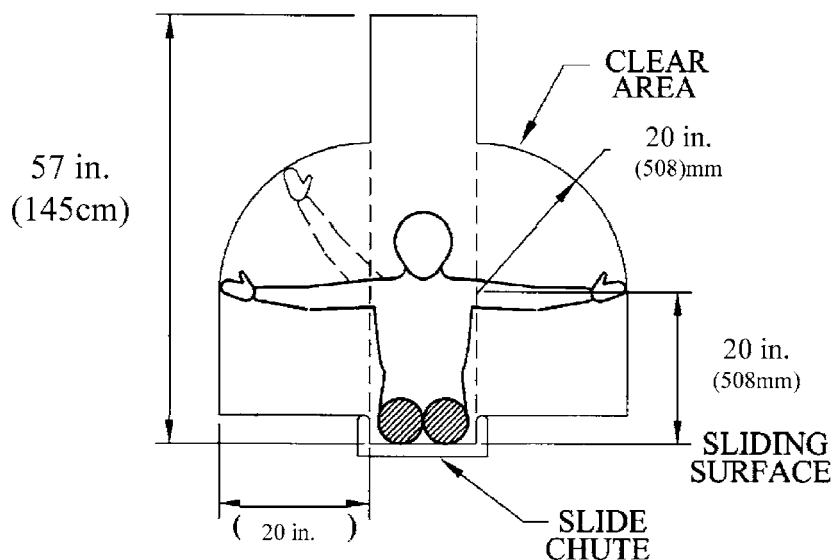

FIG. 1 Slide Clearance Zones

4.3.2 *Stability of Free-Standing Slides*— Freestanding slides, when anchored in accordance with the instructions enclosed with the slide, shall be capable of supporting a sandbag weighing the 95th percentile weight of the maximum age user (see Table 2) completely hanging over the handrail at its highest point without any part of the slide being lifted from a level supporting surface.

4.3.3 *Roller Slides*—Roller slides shall meet the specified requirements for slides in 4.3 with the exception of the requirement of continuous surface.

4.3.3.1 There shall be no pinch, crush, shear, entrapment, nor catch points between the junctures caused by two or more components that could cause a contusion, laceration, abrasion, amputation, or fracture.

(1) A pinch, crush, shear, entrapment or catch point is any point that will admit a 3/16-in. diameter neoprene rod at one or more positions, either between rollers or adjacent segments.

(2) The neoprene rod shall have a hardness reading between 50 and 60 as determined by a Type A durometer in accordance with Test Method D2240.

4.4 *Swing Set Stability*—With the swing set assembled in accordance with the manufacturers instructions, and installed with a 5° downward slope in the same direction as the swinging elements, the swing set shall remain upright when a weight equal to the 95th percentile weight for the maximum age user (see Table 2) is placed in the first two positions of the swing set and a weight equal to the 50th percentile weight is placed in all remaining positions that can be occupied by a child, and the swinging elements are swung freely in unison through the angles as specified in Table 1.

4.5 *Merry-Go-Rounds*—No stationary members of a merry-go-round device that are accessible to the child under normal conditions of use and that present an obstruction to the limbs of the user shall be located within the zone illustrated in Fig. A1.20 (for example, stationary legs within the excluded zone are not acceptable, but a single center pedestal lying within the excluded zone that is free of projections is acceptable).

4.6 *Hand Gripping/Grasping Components:*

4.6.1 *Hand Gripping Components* intended to be gripped by the hands to support body weight, such as rungs of horizontal ladders, climbing bars, handles, and the like, shall not exceed 1.55 in. (39.4 mm) in diameter or in the maximum cross-sectional dimension. When structural requirements cannot reasonably be met by the 1.55 in. diameter components, care must be exercised in selecting alternate components and designs, or both, to ensure that hand-gripping potential is not seriously impaired.

4.6.2 Hand grasping components intended to be grasped by the hand to steady the user, such as a handrail, shall have a maximum diameter or width of 1.75 in. (44.5 mm) and a minimum graspable depth of 1.5 in. (38 mm) to allow the fingers to pass over the object to be grasped. See Fig. A1.21.

4.7 *Structural Integrity*—The tests specified in 4.7.1-4.7.7 shall be performed on units assembled in accordance with the installation instructions enclosed with the equipment. There shall be no loosening, instability of the equipment, or structural failure⁸ of any component or assembly during or immediately upon completion of these tests. Where it is specified that loads on structural members shall be applied through a 3.5 in. (89-mm) long wood block, the block shall have a width of at least the width of the structural member and it shall be fabricated from lumber with a minimum thickness of 3/4 in. (19 mm) (see Tables 2 and 3). Where the geometry being tested is either too small or not flat, a loading strap 2 in. wide may be used.

4.7.1 *Handholds, Footholds, and Horizontal Supporting Members*—Rungs, steps, handles, climbing rocks, and other horizontal supporting members 24 in. (610 mm) or less in length, except turnbars and footrests, shall be capable of sustaining a vertical load (gradually applied) of 3 times the

⁸ Structural failure occurs when the equipment or any component thereof no longer meets the requirement of this consumer safety specification.

TABLE 2 Structural Integrity Loading Chart^A

Age (years)	50th Percentile, lb (kg)	95th Percentile, lb (kg)	Area Occupied by User for Platforms, ft ² (cm ²)	Rump to Sole Length for Slides in. (cm)	Area Occupied by User for Climbing Components, ft ² (cm ²)
1.5	22.7 (10.3)	26.8 (12.2)	0.6 (558)	16 (41.5)	1.4 (1302)
2	28 (12.7)	29 (13.2)	0.7 (651)	21.8 (55.2)	1.6 (1508)
3	32.8 (14.9)	42 (18.9)	0.8 (744)	25.4 (64.5)	1.9 (1760)
4	35.3 (16)	43 (19.7)	0.8 (744)	26 (66.5)	2.2 (2016)
5	39.7 (18)	50 (22.6)	0.9 (837)	29.8 (75.8)	2.3 (2139)
6	44.1 (20)	59 (26.6)	1.0 (930)	30.8 (78.1)	2.6 (2448)
7	50.5 (22.9)	69 (31.2)	1.1 (1023)	32.3 (82.1)	2.9 (2697)
8	56.2 (25.5)	81 (37)	1.2 (1116)	34.8 (88.3)	3.2 (2952)
9	63.1 (28.6)	89 (40.4)	1.3 (1209)	37 (93.6)	3.5 (3231)
10	70.5 (32)	105 (47.9)	1.4 (1302)	40.1 (102)	4.2 (3933)

^A Values given for boys or girls, whichever is higher.

TABLE 3 Minimum Test Loads for Individual Suspended Units

Unit	Test Conditions	Simultaneous Minimum Weight Load per Child Position
Swing	in swing set ^A	6 × 95 % weight of maximum age user
2 passenger occupant exposed swing (seats) ^B	in swing set	1.5 × 95 % weight of maximum age user
2 passenger occupant enclosed swing (seats) ^B	in swing set	1.5 × 95 % weight of maximum age user
2 passenger occupant enclosed swing (platforms) ^B	in swing set	1.5 × 95 % weight of maximum age user
4 passenger occupant enclosed swing (seats) ^B	in swing set ^A	1.5 × 95 % weight of maximum age user
4 passenger occupant enclosed swing (platforms) ^B	in swing set ^A	1.5 × 95 % weight of maximum age user
Trapeze	in swing set	3 × 95 % weight of maximum age user
Poles, ropes, chains, "O" rings	in swing set	3 × 95 % weight of maximum age user

^A Auxiliary support of the top bar during the test shall be permissible.

^B The seats shall be tested separately from the platforms.

4.7.2.1 For swings, ropes, and poles, a load of 1.5 times the 95th percentile weight of the maximum age user for each position normally occupied by a child at play.

4.7.2.2 For pendulum seesaws, a load of 1.2 times the 95th percentile weight of the maximum age user for each position normally occupied by a child at play.

4.7.2.3 For multiple-occupancy swings, a load of 1.1 times the 95th percentile weight of the maximum age user for each position normally occupied by a child at play.

4.7.3 *Individual Suspended Units*—Individual suspended units shall be tested one at a time, as indicated in **Table 3**, without evidence of structural failure to the unit or its supporting system. The loads shall be gradually applied and each unit shall be loaded for 5 min.

4.7.4 *Slides*—A load of the 95th percentile weight of the maximum age users shall be applied simultaneously at specified locations on the slide.

4.7.4.1 Determine the number of users, n , as follows: $n = L/d$, where L = length of the slide measure the slide at the center line of the bed way from the entrance to the exit; where d = rump to sole dimension of the 95th percentile user per **Table 2**. (Round to the next whole number.) Place n load distribution devices equally spaced on the slide bed. Load each distribution device with a downward vertical force equal to the 95th percentile weight of the oldest user. The force shall be applied gradually and then maintained for a period of 5 min. See **Fig. 2**.

4.7.5 *Rockers* (See **Fig. A1.22**)—A load of 1.6 times the 95th percentile weight of the maximum age user shall be applied vertically, without shock, to each position that would normally be occupied by a child at play, and all the loads shall remain in position simultaneously for 5 min.

4.7.6 *Merry-Go-Rounds* (See **Fig. A1.23**)—A load of 1.5 times the 95th percentile weight of the maximum age user shall be applied vertically, without shock, to each position that would normally be occupied by a child at play, and all the loads shall remain in position simultaneously for 5 min.

4.7.7 *Climbing Towers/Jungle Gyms* (See **Fig. A1.24**)—A total load of 7.5 times the 95th percentile weight of the maximum age user shall be divided and applied in five equal segments. These five loads shall be applied in the worst possible configuration (that is, in the positions that will most likely cause failure or instability, or both, of the climbing tower

95th percentile weight of the maximum age user applied for 5 min to a 3.5 in. (89 mm) long wood block resting on the center of the member. Turnbars shall be capable of sustaining a vertical load (gradually applied) of 3 times the 95th percentile weight of the maximum age user applied for 5 min to two 3.5 in. (89 mm) long wood blocks, one resting at the 1/3 and the other at the 2/3 points between the ends of the turnbar. Footrests shall be capable of sustaining a vertical load (gradually applied) of 1.5 times the 95th percentile weight of the maximum age user applied for 5 min to a 3.5 in. (89 mm) long wood block at the center of one (or the other) footrest. Horizontal members greater than 24 in. (610 mm) in length, except turnbars, shall be capable of sustaining for 5 min a vertical load of 4 times the 95th percentile weight of the maximum age user gradually applied to two 3.5 in. (89 mm) long wood blocks, one resting at the 1/3 and the other at the 2/3 points between the ends of the horizontal member. The load (or loads) shall be applied to one member at a time, unless otherwise specified for the particular equipment.

4.7.2 *Top Support Bar*—The top support bar of any swing set shall be loaded with a total load applied vertically, without shock, and the total load shall remain for 5 min. This total load shall be the sum of the following loads, as applicable:

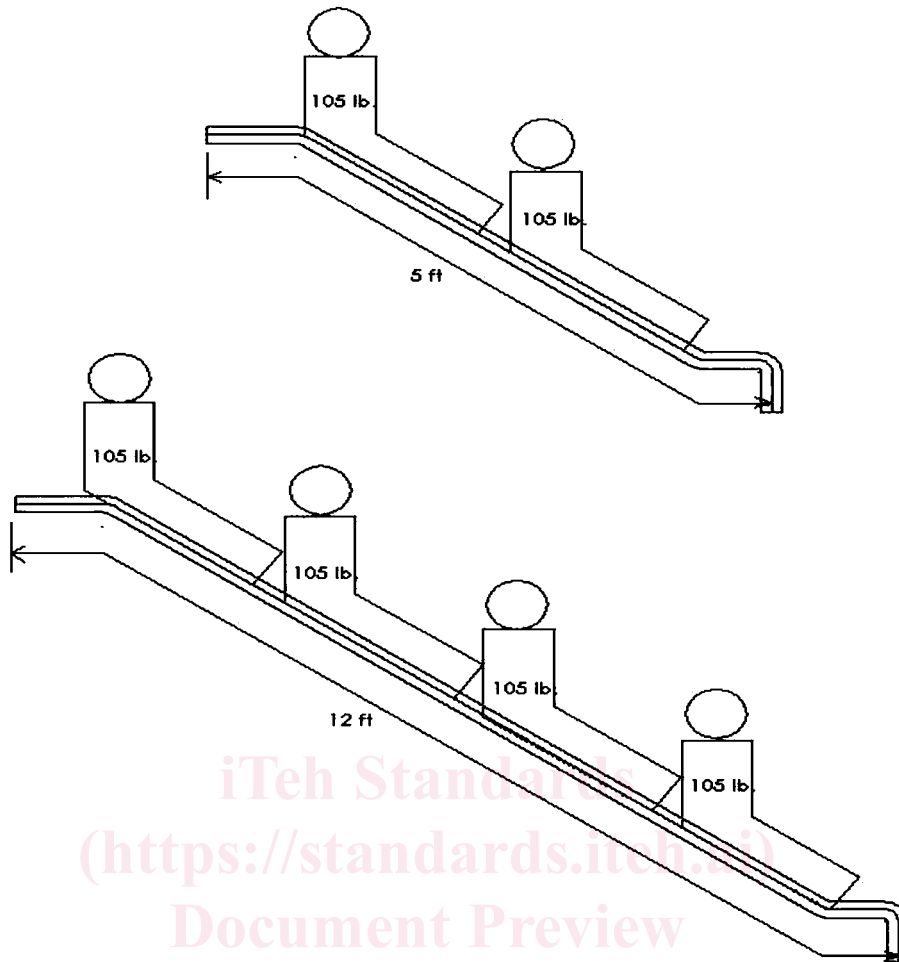

FIG. 2 Example of Slide Loading Diagram

ASTM F1148-09

<https://standards.iteh.ai/catalog/standards/sist/6703256c-49ce-4ade-85c8-3a8595872d1a/astm-f1148-09>

or jungle gym). The loads shall be applied by loading horizontal members using 3.5 in. (89 mm) long wood blocks in the center of the member, with the loads remaining simultaneously for 5 min.

4.7.8 *Platforms*—A platform shall be loaded with a total load applied vertically without shock, and the total load shall remain for 5 min. For the purpose of applying the load, the platform shall be divided into four equal area quadrants. The total load shall be located in equal portions, in the center of each quadrant and at the center point of the platform, a total of 5 points (see Fig. A1.25).

4.7.8.1 When the square foot area of a platform is smaller than the square foot area for the maximum intended user, the total load shall be applied at the center point of the platform.

4.7.8.2 For this test, weights shall be placed on load distribution devices. Each device shall be a 6 by 6 by 2 in. nominal thickness wood block.

4.7.8.3 The total load shall be the sum of the following:

(1) Based on the area of the platform, determine the maximum number of users, as follows:

$$\frac{\text{area of platform (ft}^2 \text{ (cm}^2\text{))}}{X} = N \quad (2)$$

where:

- N = maximum number of users, and
- X = area for maximum age user from Table 2.

Round to the nearest whole number.

(2) With the maximum number of users, apply the load for two 95th percentile maximum age users and the balance of the total users, 50th percentile maximum age users mass from Table 2, as follows:

$$N - 2 = N^1 \quad (3)$$

$$\begin{aligned} &2 \times 95\text{th percentile lb (kg) of maximum age user} + N^1 \\ &\quad \times 50\text{th percentile lb (kg) of maximum age user} \\ &= \text{total load} \end{aligned} \quad (4)$$

4.7.9 *Climbing Components*—Components and surfaces intended for climbing shall be loaded by hanging or placing weights, with a total load applied vertically without shock. Total load shall remain for 5 min.

Calculate number of users:

$$\text{area of climbing surface (ft}^2 \text{ (cm}^2\text{))} / A = N \quad (5)$$

where:

N = maximum number of users (round to the nearest whole number), and

A = area of climbing surface occupied by maximum age user from **Table 2**.

Calculate load:

$$B + C = \text{total load} \quad (6)$$

where:

B = weight of two 95th percentile maximum age users, and

C = $(N - 2) \times$ weight of 50th percentile maximum age user(s).

4.7.9.1 For the purpose of applying the load, the climbing component shall be divided into four equal area quadrants. The total load shall be located in equal portions, in the center of each quadrant and at the center point of the climber, a total of 5 points. In the event the location lies at an open area on the climber, the load shall be placed as reasonably close to center as possible. If footholds or handholds such as rocks, handles, etc. are attached they must also be tested individually per 4.7.1.

4.8 *Protrusions*—When tested in accordance with 4.8.1-4.8.6.1, no protrusion shall extend beyond the face of the appropriate test gage as defined in 4.8 and shown in Fig. A1.26 and Fig. A1.27.

4.8.1 Perform protrusion tests by successively placing each test gage shown in Fig. A1.26 to determine if the protrusion extends beyond the face of the smallest gage that can be successfully placed over the protrusion (for example of test gage use, see Fig. A1.28).

4.8.2 *Upright Protrusions*—Protrusions that fit within any of the gages and that project upwards from a horizontal plane shall have no projection extending more than $\frac{1}{8}$ in. (3 mm) perpendicular to the plane of the initial surface (see Fig. A1.29).

4.8.3 *Motion Rides*—Protrusions on the front and rear surfaces of suspended members of swinging elements and those on the interior surface of slides shall not protrude beyond the face of the test gage shown in Fig. A1.27. Conduct the test with the suspended member in its rest position. Place the gage shown in Fig. A1.27 over any protrusions on the front and rear surfaces of the suspended member such that the axis of the hole is parallel to both the intended path of the suspended member and a horizontal plane.

4.8.4 *Slides*—Slides, including protective barriers and their method of attachment and transition areas, pose a greater risk of entanglement than other areas of play equipment. Therefore, the following requirements apply to slides and sliding devices:

4.8.4.1 Any accessible protrusion that allows the 3.0 in. (76 mm) protrusion gage to pass over it shall have no projection extending perpendicular from the initial surface more than $\frac{1}{8}$ in. (3 mm). The area that is subject to this requirement is outlined in Fig. A1.30. The outside surface of tunnel slides that are completely enclosed are not subject to the requirements of this section.

4.8.4.2 Slides shall be constructed in such a manner as to provide a smooth continuous sliding surface with no gaps or spaces that might create an entanglement hazard such as, but not limited to, the space created between sidewalls when two single slides are combined to create a double wide slide or the

TABLE 4 Access Requirements for Rung Ladders, Stepladders and Stairways

Type of Access	
<i>Rung Ladder:</i>	
slope	60 to 90°
total ladder width	≥12 in.
vertical rise (top of rung to top of rung)	≤12 in.
<i>Stepladders:</i>	
Slope	≥50 to 75°
Tread width:	
single file access	12 to 21 in.
two-abreast access	not recommended
<i>Tread depth:</i>	
open riser	≥3 in.
closed riser	≥7 in.
vertical rise (top of step to top of step)	≤11 in.
<i>Stairways:</i>	
Slope	<50°
Tread width:	
single file access	≥12 in.
two-abreast access	≥30 in.
<i>Tread depth:</i>	
open riser	≥7 in.
closed riser	≥7 in.
vertical rise (top of step to top of step)	≤9 in.

point where a hood attaches to the sidewalls of a slide. Roller slides are exempt from the requirements of this section. See 4.3.3 for specific requirements for roller slides.

4.8.5 No protrusion may terminate in a dimension greater than that of the base dimension (see Fig. A1.31). In the case of hardware as defined in 4.1.8, the base dimension shall be defined as the major dimension of the attachment nut or bolt head.

4.8.6 *Exclusions*—Protrusions are exempt from the requirements of 4.8.2 and may be considered inaccessible if the protrusion cannot be placed within the 3.0-in. diameter test gage (see Fig. A1.31).

4.8.6.1 Rope protrusions are specifically exempted from the requirements of 4.8.

4.9 Ropes:

4.9.1 A suspended climbing rope, chain, or cable shall be secured at both ends to prevent the rope, chain or cable from being looped back on itself creating a loop with an interior perimeter of 5 in. A rope, chain, or cable that is used to support a swing seat is exempt.

4.10 Requirements for Access

4.10.1 Rung Ladders, Stepladders and Stairways:

4.10.1.1 Rungs, steps and stairs shall be evenly spaced within a tolerance of ± 0.25 in. (± 6 mm) and horizontal within a tolerance of $\pm 2^\circ$. The even spacing will include the distance between the top rung, step or stair and the top surface of the platform.

4.10.1.2 Rung ladders, stepladders and stairways shall comply with the recommendations found in **Table 4**.

4.10.2 Handrails:

4.10.2.1 Continuous handrails shall be provided on both sides of stairways and stepladders that have more than one tread. Handrails or other means of hand support shall be available for use at the beginning of the first step. The handrail shall be between 0.95 and 1.55 in. in diameter. The handrail

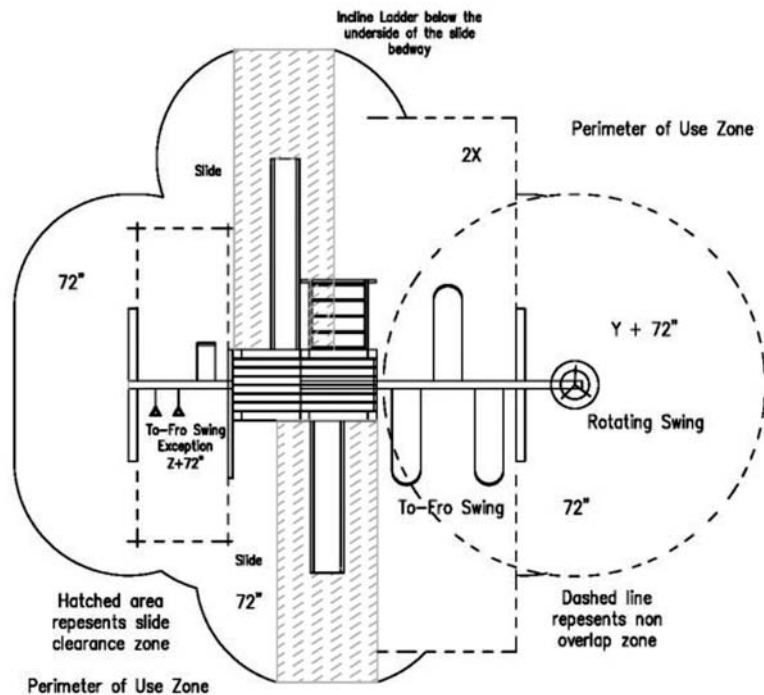

FIG. 3 Use Zones

height (the vertical distance between the top front edge of a step and the handrail above it) shall be between 22 and 38 in. (560 and 970 mm).

(1) Stairways with a tread surface area of $\geq 200 \text{ in.}^2$ must have a continuous handrail that complies with the requirements for guardrails and barriers in 4.1.13.

4.10.2.2 Open riser step ladders with a slope between 65° and 75° may be considered a climber and do not require handrails as long as a means of hand support is provide while climbing. Climbers and rung ladders must provide a means of hand support at the transition from climber to the platform. Open riser step ladders with a slope between 50° and $<65^\circ$ must meet the recommendations of 4.10.2.3.

4.10.2.3 Rung ladders and step ladders with closed risers must provide handgripping components or other means of continuous hand support beginning at the first step of a step ladder or first rung of a rung ladder that conform to the recommendations of 4.6 hand gripping/grasping components.

(1) Rung ladders shall have hand-gripping support above the platform to facilitate the transition from the ladder to the platform.

4.10.3 To-fro swinging components such as, but not limited to, swings, trapeze bars, trapeze rings, and gliders shall not be attached to upper body components such as horizontal ladders.

4.11 *Play Structure Use Zone*—There shall be a use zone for each play structure which shall consist of obstacle-free surfacing that conforms to Specification F1292 appropriate for the fall height of the equipment. The dimensions and configuration of the use zone shall be dependent upon the type of play equipment, as specified in 4.12-4.15. Use zones of certain types of equipment may overlap unless otherwise specified.

4.12 *Minimum Use Zone*—The minimum use zone for play equipment shall extend no less than 72 in. (1830 mm) from all sides of the play structure.

4.12.1 *Exceptions to the Minimum Use Zone*—Equipment that requires a user to maintain constant contact with the ground during play has no individual use zone requirements (for example, playhouses, free standing activity panels, ground level sandboxes).

4.13 *Swings*:

4.13.1 *To-Fro Swings*—The use zone to the front and to the rear of to-fro swings shall be a minimum distance of $2X$ on a line extending 90° both front and rear from the longitudinal direction of the suspending beam, where X equals the vertical distance from the top of the protective surfacing to the pivot point of the swing. The total horizontal distance from the front to the rear of the use zone shall be not less than $4X$. (See Fig. 3.)

4.13.1.1 No component of the attached play structure or separate play structure shall occupy or exit into the ground level protective surfacing area of the front-to-rear use zone of a to-fro swing.

4.13.1.2 The use zone width for to-fro swings shall be at least as wide as the supporting top rail beam.

4.13.1.3 The use zone surrounding the support structure of to-fro swings shall extend no less than 72 in. (1830 mm) in all directions from the structure (see Fig. 3). The use zone of the supporting structure may overlap other use zones.

4.13.1.4 The front to rear use zone of a trapeze bar or rings, or both, shall be $Z + 72 \text{ in.}$, where Z equals the distance from the pivot point to the lowest portion of the swinging component.

4.13.2 *Swings Capable of Unlimited Lateral Motion* (see Fig. 3):

4.13.2.1 The use zone for a swing capable of unlimited lateral motion shall be a minimum horizontal distance of $Y + 72$ in. (1830 mm) in all directions from the pivot point of the swing, where Y equals the vertical distance between the pivot point and the top of the swing seat or suspended member.

4.13.2.2 No play component of the attached play structure or separate play structure shall be located in the use zone of a swing element capable of unlimited lateral motion.

(1) Exception: Adjacent to-fro swings where the support structure of the swing is designed to minimize the likelihood of the unlimited lateral motion swing intruding into the to-fro use zone.

(2) Exception: The support structure of the swing element capable of unlimited lateral motion.

(3) Exception: The use zone for swings capable of unlimited lateral motion that are attached to the underside of a platform may overlap the use zones of other play components placed on the perimeter of the supporting platform. The swinging component may not be capable of striking a user on an adjacent play component.

4.13.2.3 The use zone surrounding the support structure of rotating swings shall extend no less than 72 in. (1830 mm) in all directions from the support structure. The use zone of the supporting structure may overlap other use zones.

4.14 *Slides* (see Fig. 3):

4.14.1 The use zone around the steps or ladder, platform, and chute or slide bed of straight, wavy, and spiral slides shall conform to the minimum use zone recommendations for play equipment found in 4.12.

4.14.2 The use zone at the lower exit end of the chute or slide bed shall extend in the direction of the descent a horizontal distance not less than 72 in. (1830 mm).

4.14.3 *Slide Exit Clearance Zone*—A clear zone, free of equipment, shall extend from the end of the slide to the perimeter of the slide use zone. This area shall have a width as shown in Fig. 3. Slide exit clearance zones for two or more slides may overlap if their sliding paths are parallel. Merging slides with converging paths of travel shall not have overlapping clearance zones as shown in Fig. 1 and Fig. 3.

(1) Exception: The slide itself may encroach into slide exit clearance zone (for example, spiral slides).

4.14.4 The clearance area of a slide exit use zone may not overlap the motion use zone of a to-fro or rotating swing.

4.15 *Composite Play Structures*:

4.15.1 The boundary of the use zone for a composite play structure shall be composed of those use zones that have been established for each individual play structure that, when joined together, comprise the composite play structure.

4.15.2 It is impractical to identify and establish assembled use zone standards for all possible configurations of a composite play structure. Therefore, the professional judgment of play equipment manufacturers, designers, and owners shall be used when designing a modular composite play structure to eliminate hazards created by conflicts in circulation use patterns or close proximity of adjacent components, or both.

5. Labeling

5.1 Each whole unit of playground equipment such as a completed play unit, accessory toddler swing or slide shall be permanently marked in a conspicuous location with the name and address (city, state, and zip code) of the manufacturer, distributor, or seller.

5.2 The following information shall be permanently and prominently displayed on the product:

THIS PRODUCT IS INTENDED FOR USE BY CHILDREN FROM AGES ____ TO ____.

5.3 Toddler Swings shall have the following information permanently and prominently displayed:

(1) Information requiring adult supervision.

(2) If a restraint system is provided, instructions to always use the restraint system should be displayed.

6. Instructions

6.1 *General Information*:

6.1.1 *Information on Manufacturer or Distributor*—The instructions shall carry in a prominent place the name and address of the manufacturer or distributor, and the model number of the playground equipment. Also, there shall be an instruction advising the buyer to save this instruction and information sheet in the event that the manufacturer has to be contacted.

6.1.2 *Information on Playground Surfacing Materials*:

6.1.2.1 The instructions shall include the manufacturer's determination of maximum fall height for the product.

6.1.2.2 Maximum fall height for the product is determined as follows:

(1) Swings = pivot point,

(2) Elevated platforms with guardrails = top surface of the guardrail,

(3) Elevated platforms with protective barriers = the height of the platform,

(4) Climbers and horizontal ladders = top surface of the component, and

(5) Rockers and seesaws = maximum height of the designated play surface normally occupied by a user.

6.1.2.3 The instructions shall also include the information found in Section 4 of the United States Consumer Product Safety Commission's (USCPSC) Outdoor Home Playground Safety Handbook or specific surfacing guidelines for the product consistent with the USCPSC Handbook. A copy of this section may be found in Appendix X3.

6.2 *Installation Instructions and Information*—The installation instructions and information shall state the following:

6.2.1 Place the equipment on level ground, not less than 6 ft (1.8 m) from any structure or obstruction such as a fence, garage, house, overhanging branches, laundry lines, or electrical wires.

6.2.2 Do not install home playground equipment over concrete, asphalt, packed earth, grass, carpet, or any other hard surface. A fall onto a hard surface can result in serious injury to the equipment user.

6.2.3 Equipment that is required by the manufacturer to be anchored, either in concrete or by ground anchors not provided