



# Standard Test Method for Dropping Point of Lubricating Grease<sup>1</sup>

This standard is issued under the fixed designation D566; the number immediately following the designation indicates the year of original adoption or, in the case of revision, the year of last revision. A number in parentheses indicates the year of last reapproval. A superscript epsilon ( $\epsilon$ ) indicates an editorial change since the last revision or reapproval.

*This standard has been approved for use by agencies of the U.S. Department of Defense.*

## 1. Scope

1.1 This test method covers the determination of the dropping point of lubricating grease.

1.2 This test method is not recommended for use at bath temperatures above 288°C. For higher temperatures Test Method D2265 should be used.

1.3 The values stated in SI units are to be regarded as standard. No other units of measurement are included in this standard.

1.4 *This standard does not purport to address all of the safety concerns, if any, associated with its use. It is the responsibility of the user of this standard to establish appropriate safety and health practices and determine the applicability of regulatory limitations prior to use.* For specific hazard statements, see 6.4 and 8.1.

## 2. Referenced Documents

2.1 *ASTM Standards:*<sup>2</sup>

D217 Test Methods for Cone Penetration of Lubricating Grease

D235 Specification for Mineral Spirits (Petroleum Spirits) (Hydrocarbon Dry Cleaning Solvent)

D2265 Test Method for Dropping Point of Lubricating Grease Over Wide Temperature Range

E1 Specification for ASTM Liquid-in-Glass Thermometers

## 3. Terminology

3.1 *Definitions:*

<sup>1</sup> This test method is under the jurisdiction of ASTM Committee D02 on Petroleum Products, Liquid Fuels, and Lubricants and is the direct responsibility of Subcommittee D02.G0.03 on Physical Tests.

Current edition approved April 15, 2009. Published July 2009. Originally approved in 1940. Last previous edition approved in 2002 as D566-02. DOI: 10.1520/D0566-02R09.

In the IP, this test method is under the jurisdiction of the Standardization Committee. This test method was adopted as a joint ASTM-IP standard in 1964.

This test method has been adopted for use by government agencies to replace Method 1421 of Federal Test Method Standard No. 791b.

<sup>2</sup> For referenced ASTM standards, visit the ASTM website, www.astm.org, or contact ASTM Customer Service at service@astm.org. For *Annual Book of ASTM Standards* volume information, refer to the standard's Document Summary page on the ASTM website.

3.1.1 *lubricating grease, n*—a semi-fluid to solid product of a thickener in a liquid lubricant.

3.1.1.1 *Discussion*—The dispersion of the thickener forms a two-phase system and immobilizes the liquid lubricant by surface tension and other physical forces. Other ingredients are commonly included to impart special properties. **D217**

3.1.2 *thickener, n*—in lubricating grease, a substance composed of finely-divided particles dispersed in a liquid to form the product's structure.

3.1.2.1 *Discussion*—Thickeners can be fibers (such as various metallic soaps) or plates or spheres (such as certain non-soaps thickeners), which are insoluble or, at most, only very slightly soluble in the liquid lubricant. The general requirements are that the solid particles are extremely small, uniformly dispersed and capable of forming a relatively stable, gel-like structure with the liquid lubricant. **D217**

3.2 *Definitions of Terms Specific to This Standard:*

3.2.1 *dropping point, n*—a numerical value assigned to a grease composition representing the temperature at which the first drop of material falls from the test cup; that temperature being the average of the thermometer readings of the sample and bath.

3.2.1.1 *Discussion*—In the normal and proper operation of this test method the temperature of the interior of the grease test cup and the temperature of the oil bath are monitored simultaneously as the bath is heated. When the first drop of material falls from the cup, the temperature of the grease test cup and the bath temperature are averaged and recorded as the result of the test.

## 4. Summary of Test Method

4.1 A sample of lubricating grease contained in a cup suspended in a test tube is heated in an oil bath at a prescribed rate. The temperature at which material falls from the hole in the bottom of the cup is averaged with the temperature of the oil bath and recorded as the dropping point of the grease.

## 5. Significance and Use

5.1 In general, the dropping point is the temperature at which the grease passes from a semisolid to a liquid state under the conditions of test. This change in state is typical of greases containing as thickeners soaps of conventional types. Greases

containing as thickeners materials other than conventional soaps can, without change in state, separate oil. This test method is useful to assist in identifying the grease as to type and for establishing and maintaining bench marks for quality control. The results are considered to have only limited significance with respect to service performance as dropping point is a static test.

NOTE 1—Cooperative testing indicates that in general, dropping points by Test Method D566<sup>3</sup> and Test Method D2265 are in agreement. In cases where results differ, there is no known significance. However, agreement between producer and consumer as to the test method used is advisable.

## 6. Apparatus

6.1 *Grease Cup*—A chromium-plated brass cup conforming to the dimensions shown in Fig. 1.

6.2 *Test Tube*—A test tube of heat-resistant glass,<sup>4</sup> with rim, 100 to 103 mm in length and 11.1 to 12.7 mm in inside diameter provided with three indentations about 19 mm from the bottom, equally spaced on the circumference. The depth of these indentations shall be such as to support the grease cup at about the point shown in Fig. 2.

6.3 *Thermometers*, two, having ranges as shown below and conforming to the requirements prescribed in Specification E1:

Temperature Range	Thermometer Number	
	ASTM	IP
-5 to + 300°C	2C	62C

6.4 *Accessories*—A stirred oil bath consisting of a 400-mL beaker, a ring stand and ring for support of the oil bath, clamps for thermometers, two corks as illustrated in Fig. 2, a polished metal rod 1.2 to 1.6 mm in diameter and 150 to 152 mm in length (Fig. 3), a cup plug gage and thermometer depth gage, both shown in Fig. 1. (**Warning**—The fluid for the oil bath must have a flash point in excess of the maximum temperature at which the bath is to be used<sup>5</sup> and allowance must be made for thermal expansion to prevent overflow. Heating is preferably done by an immersed electrical-resistance heater regulated by voltage control. An open flame must not be used as the heating source.) (**Warning**—When a hot plate is used, care must be taken to avoid spilling oil on the hot surface.)

## 7. Sampling

7.1 When ready to test, examine the sample for any indication of non-homogeneity such as oil separation, phase changes, or gross contamination. When any abnormal conditions are noted, obtain a new sample.

## 8. Preparation of Apparatus

8.1 Thoroughly clean the cup and test tube with mineral spirits conforming to Specification D235. (**Warning**—Flammable. Vapor harmful.)

<sup>3</sup> Supporting data have been filed at ASTM International Headquarters and may be obtained by requesting Research Report: RR:D02-1164.

<sup>4</sup> Borosilicate glass has been found satisfactory for this purpose.

<sup>5</sup> Dow Corning 710 Fluid has been found satisfactory when bath temperatures as high as 288°C are required. Dow Corning is a registered trademark of the Dow Corning Corp., Midland, MI 48686.

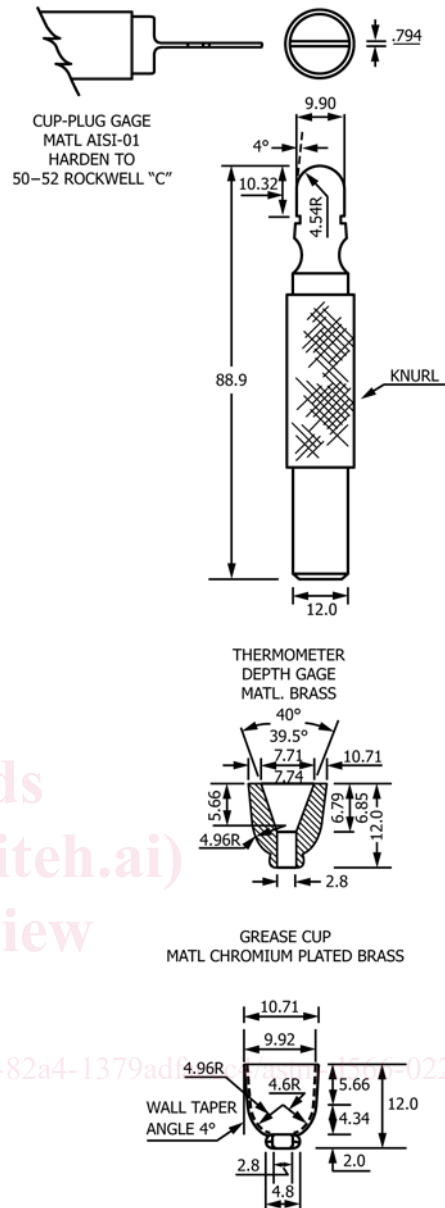

NOTE 1—Dimensions in millimetres.

FIG. 1 Plug Gage, Depth Gage, and Grease Cup

8.2 Use only cups that are clean and free from any residue from previous runs. When the interior plating of the cup shows indications of wear, discard.

8.3 When new cups are to be used, check their dimensions by using the cup plug gage (Fig. 1). To check the bottom opening a 2.72-mm rod should fit easily while a 2.82-mm rod should not.<sup>6</sup> If the hole is undersized, ream to correct size. If too large, discard.

8.4 Test tube shall be clean and free of residues. Inspect the tube for evidence of chipping or cracking, particularly the points of indentation. Replace when necessary.

<sup>6</sup> These are commonly available as a 7/64-in. drill and a No. 34 drill, respectively.