

DRAFT INTERNATIONAL STANDARD

ISO/DIS 24410

ISO/TC 127/SC 2

Secretariat: ANSI

Voting begins on:
2019-10-01

Voting terminates on:
2019-12-24

Earth-moving machinery — Coupling of attachments to skid steer loaders

Engins de terrassement — Attelage des accessoires des chargeuses à direction articulée

ICS: 53.100

iTeh STANDARD PREVIEW
(standards.iteh.ai)
Full standard:
<https://standards.iteh.ai/catalog/standards/sist/1b48cc72-ddad-4807-addc-88e0efcf3dd2/iso-fdis-24410>

THIS DOCUMENT IS A DRAFT CIRCULATED FOR COMMENT AND APPROVAL. IT IS THEREFORE SUBJECT TO CHANGE AND MAY NOT BE REFERRED TO AS AN INTERNATIONAL STANDARD UNTIL PUBLISHED AS SUCH.

IN ADDITION TO THEIR EVALUATION AS BEING ACCEPTABLE FOR INDUSTRIAL, TECHNOLOGICAL, COMMERCIAL AND USER PURPOSES, DRAFT INTERNATIONAL STANDARDS MAY ON OCCASION HAVE TO BE CONSIDERED IN THE LIGHT OF THEIR POTENTIAL TO BECOME STANDARDS TO WHICH REFERENCE MAY BE MADE IN NATIONAL REGULATIONS.

RECIPIENTS OF THIS DRAFT ARE INVITED TO SUBMIT, WITH THEIR COMMENTS, NOTIFICATION OF ANY RELEVANT PATENT RIGHTS OF WHICH THEY ARE AWARE AND TO PROVIDE SUPPORTING DOCUMENTATION.

This document is circulated as received from the committee secretariat.



Reference number
ISO/DIS 24410:2019(E)

© ISO 2019

iTeh STANDARD PREVIEW
(standards.iteh.ai)
Full standard:
<https://standards.iteh.ai/catalog/standards/sist/1b48cc72-ddad-4807-addc-88e0efcf3dd2/iso-fdis-24410>



COPYRIGHT PROTECTED DOCUMENT

© ISO 2019

All rights reserved. Unless otherwise specified, or required in the context of its implementation, no part of this publication may be reproduced or utilized otherwise in any form or by any means, electronic or mechanical, including photocopying, or posting on the internet or an intranet, without prior written permission. Permission can be requested from either ISO at the address below or ISO's member body in the country of the requester.

ISO copyright office
CP 401 • Ch. de Blandonnet 8
CH-1214 Vernier, Geneva
Phone: +41 22 749 01 11
Fax: +41 22 749 09 47
Email: copyright@iso.org
Website: www.iso.org

Published in Switzerland

Contents

	Page
Foreword.....	iv
Introduction.....	v
1 Scope.....	1
2 Normative references.....	1
3 Terms and definitions.....	1
4 General requirements.....	2
5 Safety requirements.....	4
6 Attachment mounting frame dimensions.....	4
Annex A (informative) Mechanics of a skid steer loader quick coupler.....	8
Annex B (informative) Width dimensions for narrow skid steer loader coupler.....	10
Bibliography.....	11

iTeh STANDARD PREVIEW
 (standards.iteh.ai)

Full standard:
<https://standards.iteh.ai/catalog/standards/sist/1b48cc72-ddad-4807-addc-88e0efcf3dd2/iso-fdis-24410>

Foreword

ISO (the International Organization for Standardization) is a worldwide federation of national standards bodies (ISO member bodies). The work of preparing International Standards is normally carried out through ISO technical committees. Each member body interested in a subject for which a technical committee has been established has the right to be represented on that committee. International organizations, governmental and non-governmental, in liaison with ISO, also take part in the work. ISO collaborates closely with the International Electrotechnical Commission (IEC) on all matters of electrotechnical standardization.

The procedures used to develop this document and those intended for its further maintenance are described in the ISO/IEC Directives, Part 1. In particular the different approval criteria needed for the different types of ISO documents should be noted. This document was drafted in accordance with the editorial rules of the ISO/IEC Directives, Part 2 (see www.iso.org/directives).

Attention is drawn to the possibility that some of the elements of this document may be the subject of patent rights. ISO shall not be held responsible for identifying any or all such patent rights. Details of any patent rights identified during the development of the document will be in the Introduction and/or on the ISO list of patent declarations received (see www.iso.org/patents).

Any trade name used in this document is information given for the convenience of users and does not constitute an endorsement.

For an explanation on the voluntary nature of standards, the meaning of ISO specific terms and expressions related to conformity assessment, as well as information about ISO's adherence to the World Trade Organization (WTO) principles in the Technical Barriers to Trade (TBT) see the following URL: www.iso.org/iso/foreword.html.

This document was prepared by Technical Committee ISO/TC 127, *Earth-moving machinery*, Subcommittee SC 2, *Safety, ergonomics and general requirements*.

This second edition cancels and replaces the first edition (ISO 24410:2005), which has been technically revised.

The main changes compared to the previous edition are as follows:

- addition of safety requirements
- addition of informative annex regarding the mechanics of a skid steer loader quick coupler
- addition of width dimensions for narrow skid steer loader attachment mounting frame

Introduction

Quick couplers typical to skid steer loaders are now used on other types of compact products, e.g. compact loaders, compact tractors, compact rough-terrain forklift trucks. The growth of the use of this style quick coupler with other products has resulted in the need to provide guidance regarding the design principles of this quick coupler system.

The previous version of this document only provided the dimensional requirements for the mounting frame on the attachment. Dimensions for the quick coupler itself were not provided as these dimensions are dependent on the design of the quick coupler. This revision of the document also does not provide dimensional requirements for the quick coupler itself, however it does provide guidance for the quick coupler engagement system.

iTeh STANDARD PREVIEW
(standards.iteh.ai)

Full standard:
<https://standards.iteh.ai/catalog/standards/sist/1b48cc72-ddad-4807-addc-88e0efcf3dd2/iso-fdis-24410>

iTeh STANDARD PREVIEW
(standards.iteh.ai)

Full standard:
<https://standards.iteh.ai/catalog/standards/sist/1b48cc72-ddad-4807-addc-88e0efcf3dd2/iso-fdis-24410>

Earth-moving machinery — Coupling of attachments to skid steer loaders

1 Scope

This document provides for the interchangeability of attachments on skid steer loaders by establishing requirements for the quick coupler system including dimensional limits for the attachment mounting frame. These quick couplers are typically used on skid steer loaders as defined in ISO 6165.

NOTE 1 Skid steer loaders can use other styles of quick couplers but the coupler would not be interchangeable with attachments designed to comply with this document.

NOTE 2 The requirements of this document can be applied to quick couplers used on other compact machines.

NOTE 3 Quick couplers used on small skid steer loaders and some compact tool carriers can have a different width requirement than provided in this document. See [Annex B](#).

2 Normative references

The following documents are referred to in the text in such a way that some or all of their content constitutes requirements of this document. For dated references, only the edition cited applies. For undated references, the latest edition of the referenced document (including any amendments) applies.

ISO 6165, *Earth-moving machinery — Basic types — Identification and terms and definitions*

ISO 6746-2, *Earth-moving machinery — Definitions of dimensions and codes — Part 2: Equipment and attachments*

ISO 13031:2016, *Earth-moving machinery — Quick couplers — Safety*

3 Terms and definitions

For the purposes of this document, the terms and definitions given in ISO 6165 and ISO 6746-2 and the following apply.

ISO and IEC maintain terminological databases for use in standardization at the following addresses:

- ISO Online browsing platform: available at <http://www.iso.org/obp>
- IEC Electropedia: available at <http://www.electropedia.org/>

3.1

quick coupler

device mounted on a skid steer loader to allow quick interchange of attachments

[SOURCE: ISO 13031:2016, [3.1](#), modified — The term “earth-moving machine” is replaced by “skid steer loader”, and Note 1 to entry is not included here]

3.2

attachment mounting frame

attachment component that facilitates the quick mounting and removal of an attachment to the *quick coupler* ([3.1](#))

**3.3
engagement system**

mechanical system of the *quick coupler* (3.1) which engages with the *attachment mounting frame* (3.2) and retains the attachment in its working position

[SOURCE: ISO 13031:2016, 3.2, modified — The term “attachment” is replaced by “attachment mounting frame”]

**3.3.1
wedge-type engagement system**

engagement system (3.3) of at least two interconnecting parts which engage with one another in a wedge action whereby the combination of the wedge angle and the friction coefficient counteract the tendency of the *working forces* (3.4) to cause disengagement

[SOURCE: ISO 13031:2016, 3.2.4, modified — The Note 1 to entry is not included here]

**3.4
working forces**

forces created by the working operations of the skid steer loader and attachments that act upon the *quick coupler* (3.1) during intended use and reasonably foreseeable misuse

[SOURCE: ISO 13031:2016, 3.3.1, modified — The term “earth-moving machine” is replaced by “skid steer loader”]

4 General requirements

The quick coupler system shall be designed in accordance with 5 and 6 and the following.

- a) The dimensions of the quick coupler should be such that the interface of the vertical face of the quick coupler and the attachment mounting frame does not result in surface-to-surface contact when engaged and locked together. This connection shall result in contact in each of the three zones of interface contact surface and a resulting gap between the quick coupler and the attachment mounting frame during all operating modes of the loader and attachment. See [Figure 1](#).

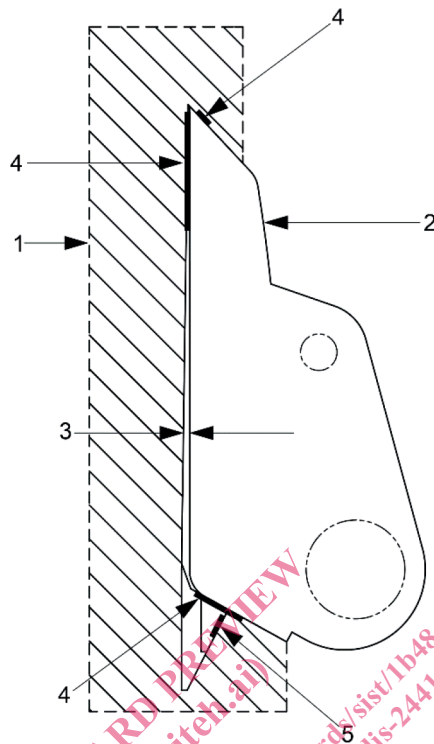
**Key**

- 1 attachment mounting frame
- 2 quick coupler
- 3 gap
- 4 zone of interface contact surface
- 5 wedge/pin contact surface

Figure 1 — Quick coupler to attachment mounting frame

b) See [Figure 5](#). The quick coupler shall not protrude

- above surface A,
- forward of surface B, or
- below surface C.

NOTE Some attachments could require added support structure to the attachment mounting frame between surfaces A and B.

c) The linkage of the quick coupler to the loader lift arms should provide a minimum of 5° rollback beyond vertical of the quick coupler towards the loader with the lift arms in their lowest position. The amount of rollback may be less for quick couplers used on smaller skid steer loaders and compact tool carriers.