



SLOVENSKI STANDARD

SIST ISO 2203:1995

01-junij-1995

HM b] bYf]gVY!'CV] U'bc`df]_Uncj Ub'Y'ncVb]_cj

Technical drawings -- Conventional representation of gears

Dessins techniques -- Représentation conventionnelle des engrenages

Ta slovenski standard je istoveten z: **ISO 2203:1973**

[SIST ISO 2203:1995](https://standards.iteh.ai/catalog/standards/sist/8b95444e-4021-48a7-a3fc-5b8f92a577d2/sist-iso-2203-1995)

<https://standards.iteh.ai/catalog/standards/sist/8b95444e-4021-48a7-a3fc-5b8f92a577d2/sist-iso-2203-1995>

ICS:

01.100.20	Konstrukcijske risbe	Mechanical engineering drawings
21.200	Gonila	Gears

SIST ISO 2203:1995

en

iTeh STANDARD PREVIEW
(standards.iteh.ai)

[SIST ISO 2203:1995](#)

<https://standards.iteh.ai/catalog/standards/sist/8b95444e-4021-48a7-a3fc-5b8f92a577d2/sist-iso-2203-1995>

INTERNATIONAL STANDARD



2203

INTERNATIONAL ORGANIZATION FOR STANDARDIZATION · МЕЖДУНАРОДНАЯ ОРГАНИЗАЦИЯ ПО СТАНДАРТИЗАЦИИ · ORGANISATION INTERNATIONALE DE NORMALISATION

Technical drawings – Conventional representation of gears

First edition – 1973-03-15

ITeH STANDARD PREVIEW
(standards.iteh.ai)

[SIST ISO 2203:1995](https://standards.iteh.ai/catalog/standards/sist/8b95444e-4021-48a7-a3fc-5b8f92a577d2/sist-iso-2203-1995)

<https://standards.iteh.ai/catalog/standards/sist/8b95444e-4021-48a7-a3fc-5b8f92a577d2/sist-iso-2203-1995>

UDC 744.4 : 621.83

Ref. No. ISO 2203-1973 (E)

Descriptors : drawings, engineering drawings, gears, chain wheels, representation.

FOREWORD

ISO (the International Organization for Standardization) is a worldwide federation of national standards institutes (ISO Member Bodies). The work of developing International Standards is carried out through ISO Technical Committees. Every Member Body interested in a subject for which a Technical Committee has been set up has the right to be represented on that Committee. International organizations, governmental and non-governmental, in liaison with ISO, also take part in the work.

Draft International Standards adopted by the Technical Committees are circulated to the Member Bodies for approval before their acceptance as International Standards by the ISO Council.

International Standard ISO 2203 was drawn up by Technical Committee ISO/TC 10, *Technical drawings*, and circulated to the Member Bodies in January 1971.

It has been approved by the Member Bodies of the following countries:

Australia	Hungary	Portugal
Austria	India	Romania
Belgium	Ireland	South Africa, Rep. of
Canada	Israel	Sweden
Chile	Italy	Switzerland
Czechoslovakia	Japan	Turkey
Denmark	Korea, Dem.P.Rep. of	United Kingdom
Egypt, Arab Rep. of	Korea, Rep. of	U.S.A.
France	Netherlands	U.S.S.R.
Germany	New Zealand	
Greece	Norway	

No Member Body expressed disapproval of the document.

Technical drawings – Conventional representation of gears

1 SCOPE AND FIELD OF APPLICATION

This International Standard establishes the conventional representation of the toothed portion of gears including worm gearing and chain wheels. It is applicable to detail drawings and assembly drawings.

As a fundamental principle a gear is represented (except in axial section) as a solid part without teeth, but with the addition of the pitch surface in a thin long chain line.

NOTE – For uniformity all figures in this International Standard are in first angle projection (Method E). It should be understood that the third angle projection (Method A) could equally well have been used without prejudice to the principles established.

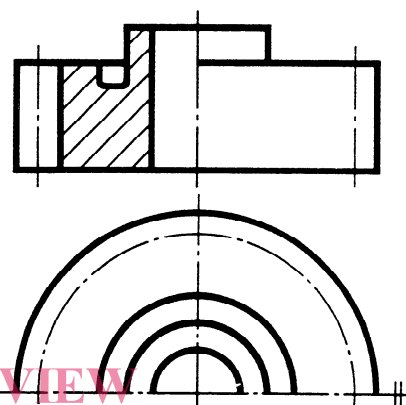

FIGURE 1

2 DETAIL DRAWINGS (INDIVIDUAL GEARS)

2.1 Contours and edges

Represent the contours and the edges of each gear (see Figures 1, 2 and 3), as if they were,

- in an unsectioned view, a solid gear bounded by the tip surface;
- in an axial section, a spur gear having two diametrically opposed teeth, represented unsectioned, even in the case of a gear that does not have spur teeth or that has an odd number of teeth.

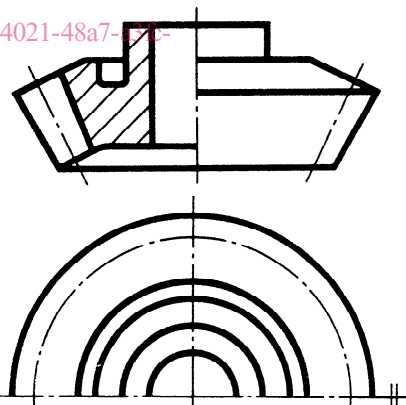

FIGURE 2

2.2 Pitch surface

Draw the pitch surface with a thin, long chain line, even in concealed portions and sectional views, and represent it,

- in a projection normal to the axis, by its pitch circle (external pitch circle in the case of a bevel gear and the median pitch circle in the case of a worm wheel) (see Figures 1, 2 and 3);
- in a projection parallel to the axis, by its apparent contour, extending the line beyond the gear contour on each side (see Figures 1, 2 and 3).

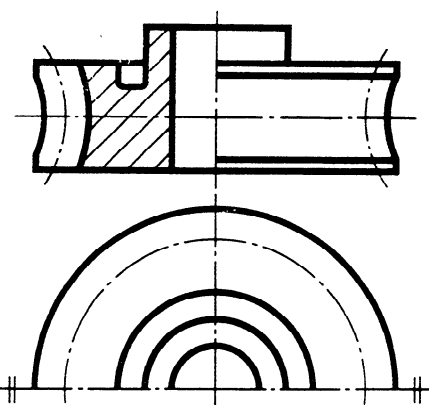

FIGURE 3

ISO 2203-1973 (E)

2.3 Root surface

As a general rule, do not represent the root surface except in sectional views.

However, if it seems helpful to show it also on unsectioned views, always draw it, in this case, as a thin continuous line (see Figures 4, 5 and 6).

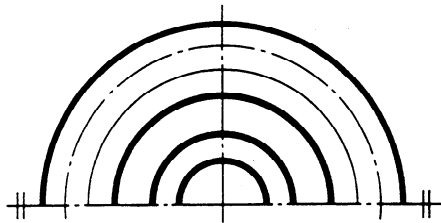
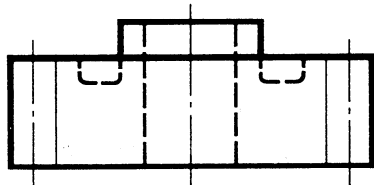

FIGURE 4

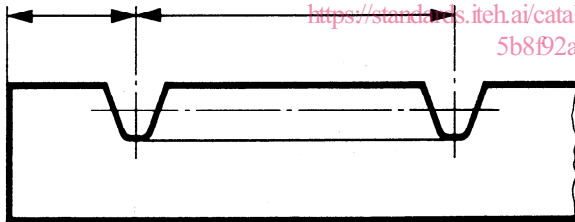

FIGURE 5

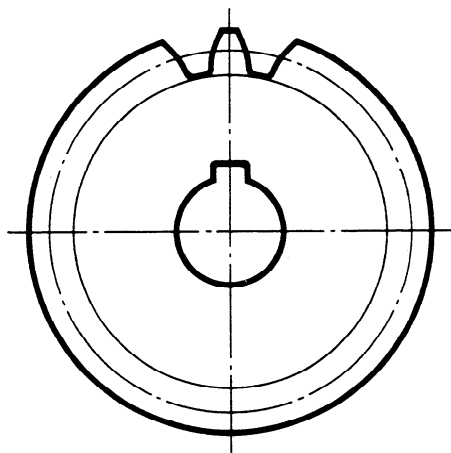

FIGURE 6

2.4 Teeth

Specify the teeth profile either by reference to a standard or by a drawing to a suitable scale.

If it is essential to show one or two teeth on the drawing itself (either to define the ends of a toothed portion or rack, or in order to specify the position of the teeth in relation to a given axial plane), draw them as thick continuous lines (see Figures 5 and 6).

It is necessary to indicate the direction of the teeth of a gear or rack on the view of the tooth surface in a projection parallel to the gear axes, three thin continuous lines of the corresponding form and direction should be shown (see Table and Figure 7).

TABLE

Tooth system	Symbol
Helical to the right	
Helical to the left	
Double helical	
Spiral	

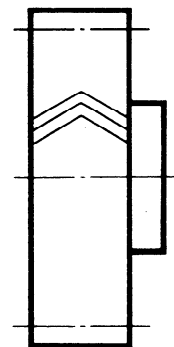
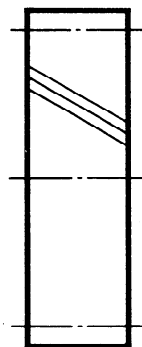

FIGURE 7

NOTE — If mating gears are represented, the direction of the teeth should be shown on one gear only.

3 ASSEMBLY DRAWINGS (GEAR PAIRS)

The specified rules for the representation of gears on detail drawings are equally applicable to assembly drawings. However, for a pair of bevel gears in projection parallel to the axis, extend the line drawn for the pitch surface to the point where the axes meet (see Figures 9 and 10).

Neither of the two gears of a gear pair is assumed to be hidden by the other in the portion in mesh (see Figure 8), except in the following two cases :

- 1) if one of the gears, the whole of which is located in front of the other, effectively conceals part of it (see Figures 9, 10 and 11);
- 2) if both gears are represented in axial section, in which case one of the two gears, chosen arbitrarily, is assumed to be partly concealed by the other (see Figure 9).

In these two cases, concealed contour edges need not be represented if they are not essential to the clarity of the drawing (see Figures 9 and 10).

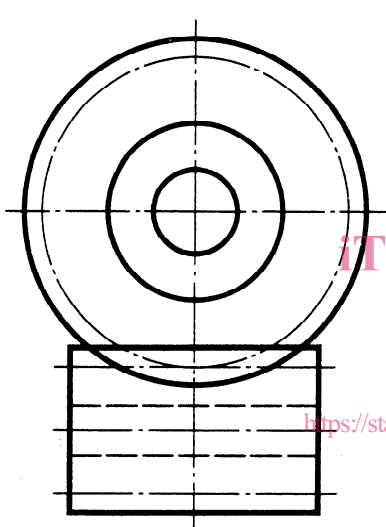

FIGURE 8

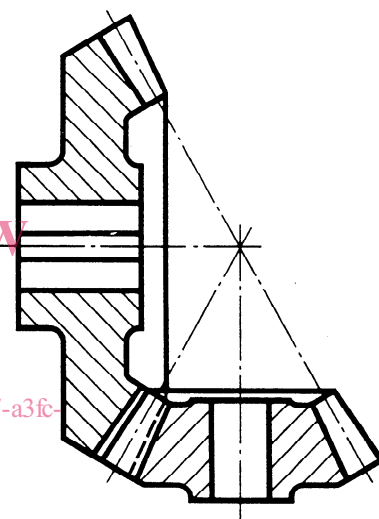
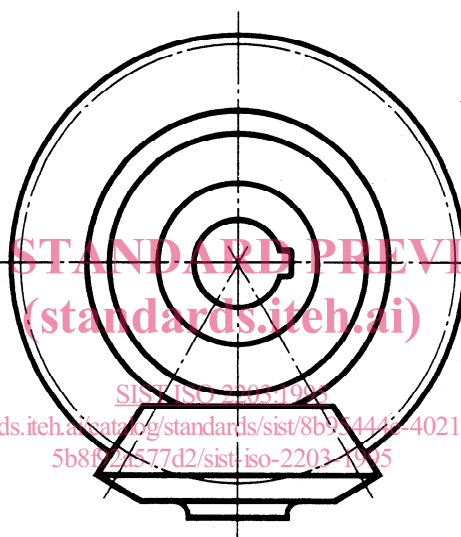

FIGURE 9

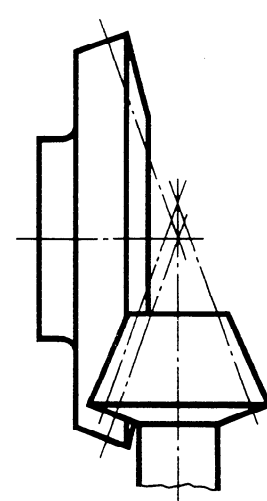
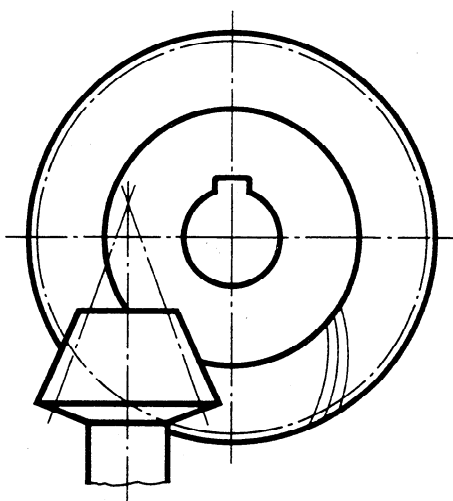
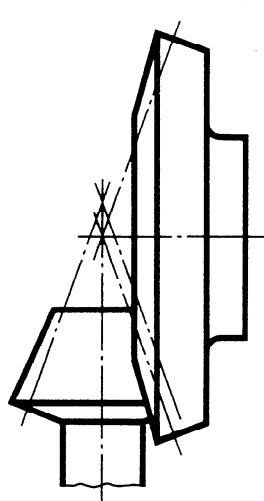

FIGURE 10

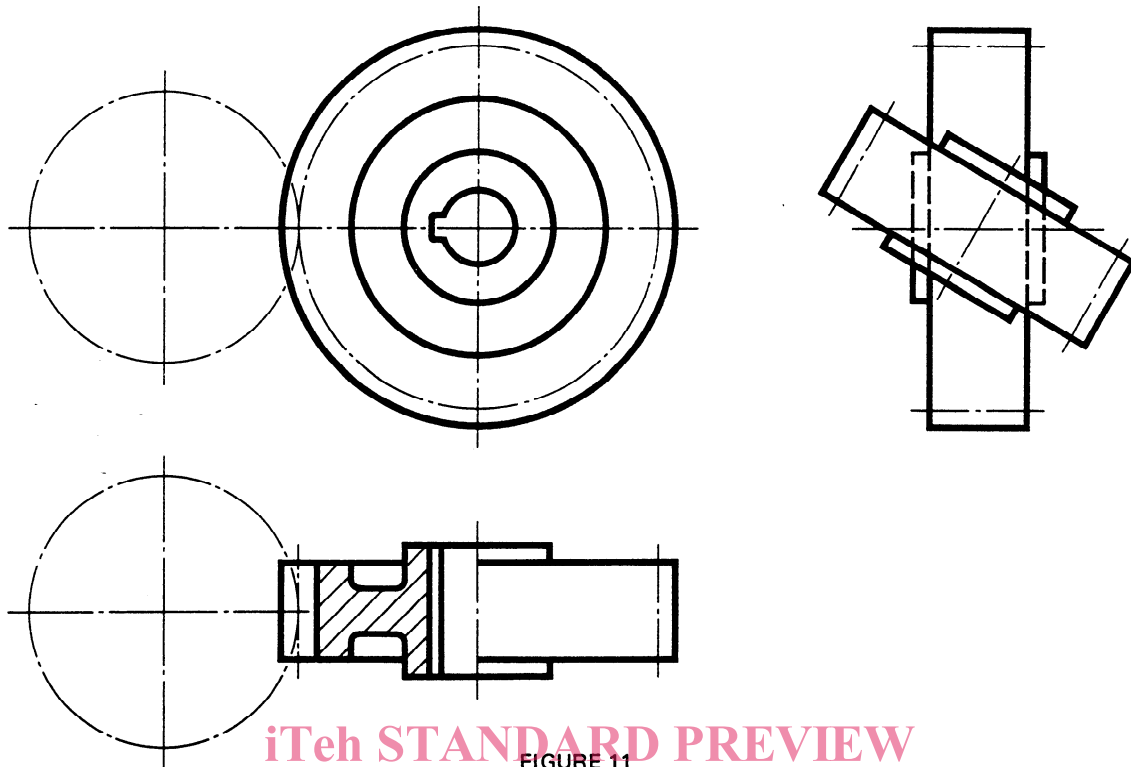

FIGURE 11

3.1 External engagement of cylindrical gears

iTeh STANDARD PREVIEW
(standards.iteh.ai)

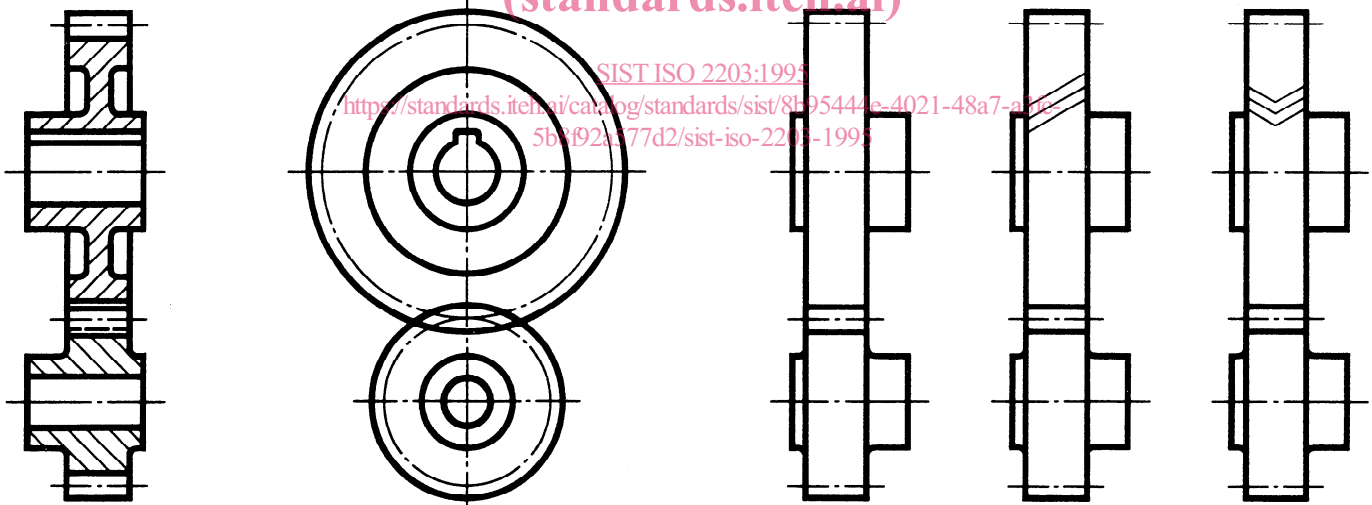

FIGURE 12

3.2 Internal engagement of cylindrical gears

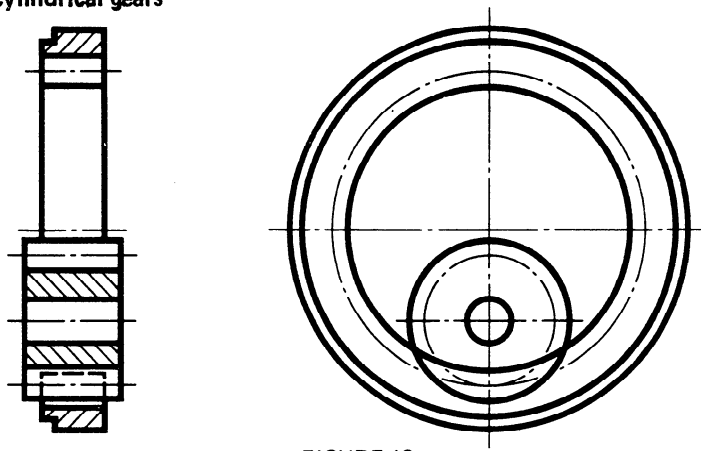
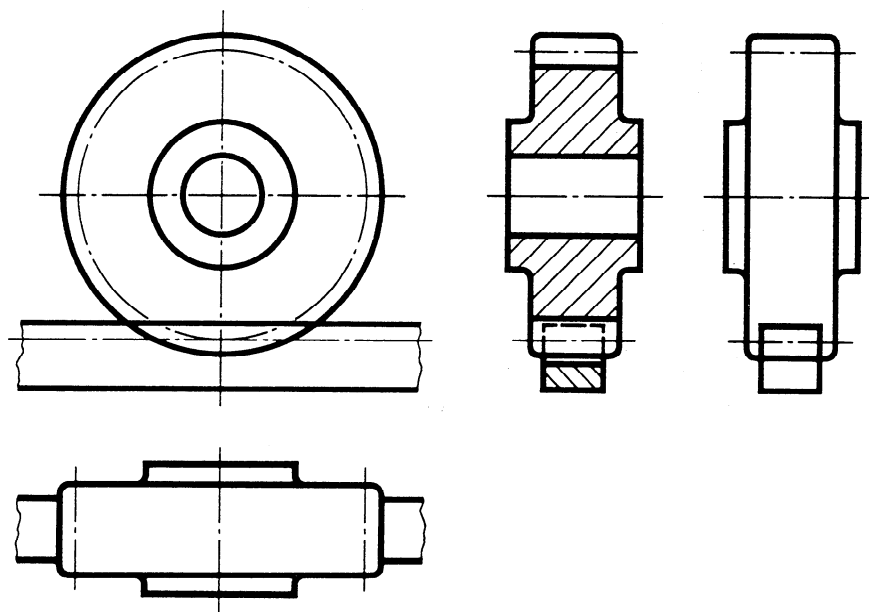

FIGURE 13

3.3 Engagement of pinion with rack



iTeh STANDARD PREVIEW
(standards.iteh.ai)

FIGURE 14

SIST ISO 2203:1995

<https://standards.iteh.ai/catalog/standards/sist/8b95444e-4021-48a7-a3fc->

3.4 Engagement of bevel gears, axis intersection at any angle

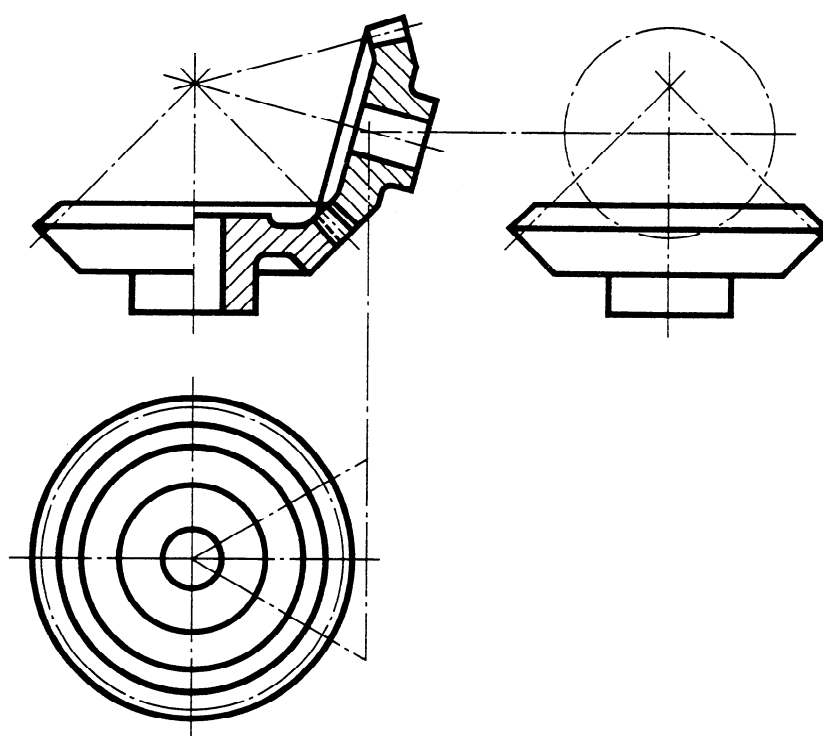

FIGURE 15