

# ETSI TS 129 334 V13.11.0 (2024-04)



**Digital cellular telecommunications system (Phase 2+) (GSM);  
Universal Mobile Telecommunications System (UMTS);**

**LTE;**

**IMS Application Level Gateway (IMS-ALG)**

**– IMS Access Gateway (IMS-AGW);**

**Iq Interface;**

**Stage 3**

**(3GPP TS 29.334 version 13.11.0 Release 13)**



A GLOBAL INITIATIVE



---

**Reference**

RTS/TSGC-0429334vdb0

---

**Keywords**

GSM,LTE,UMTS

**ETSI**

---

650 Route des Lucioles  
F-06921 Sophia Antipolis Cedex - FRANCE

Tel.: +33 4 92 94 42 00 Fax: +33 4 93 65 47 16

Siret N° 348 623 562 00017 - APE 7112B  
Association à but non lucratif enregistrée à la  
Sous-Préfecture de Grasse (06) N° w061004871

---

**Important notice**

The present document can be downloaded from:

<https://www.etsi.org/standards-search>

The present document may be made available in electronic versions and/or in print. The content of any electronic and/or print versions of the present document shall not be modified without the prior written authorization of ETSI. In case of any existing or perceived difference in contents between such versions and/or in print, the prevailing version of an ETSI deliverable is the one made publicly available in PDF format at [www.etsi.org/deliver](http://www.etsi.org/deliver).

Users of the present document should be aware that the document may be subject to revision or change of status.

Information on the current status of this and other ETSI documents is available at

<https://portal.etsi.org/TB/ETSIDeliverableStatus.aspx>

If you find errors in the present document, please send your comment to one of the following services:

<https://portal.etsi.org/People/CommitteeSupportStaff.aspx>

If you find a security vulnerability in the present document, please report it through our

Coordinated Vulnerability Disclosure Program:

<https://www.etsi.org/standards/coordinated-vulnerability-disclosure>

---

**Notice of disclaimer & limitation of liability**

The information provided in the present deliverable is directed solely to professionals who have the appropriate degree of experience to understand and interpret its content in accordance with generally accepted engineering or other professional standard and applicable regulations.

No recommendation as to products and services or vendors is made or should be implied.

No representation or warranty is made that this deliverable is technically accurate or sufficient or conforms to any law and/or governmental rule and/or regulation and further, no representation or warranty is made of merchantability or fitness for any particular purpose or against infringement of intellectual property rights.

In no event shall ETSI be held liable for loss of profits or any other incidental or consequential damages.

Any software contained in this deliverable is provided "AS IS" with no warranties, express or implied, including but not limited to, the warranties of merchantability, fitness for a particular purpose and non-infringement of intellectual property rights and ETSI shall not be held liable in any event for any damages whatsoever (including, without limitation, damages for loss of profits, business interruption, loss of information, or any other pecuniary loss) arising out of or related to the use of or inability to use the software.

---

**Copyright Notification**

No part may be reproduced or utilized in any form or by any means, electronic or mechanical, including photocopying and microfilm except as authorized by written permission of ETSI.

The content of the PDF version shall not be modified without the written authorization of ETSI.

The copyright and the foregoing restriction extend to reproduction in all media.

© ETSI 2024.  
All rights reserved.

---

# Intellectual Property Rights

## Essential patents

IPRs essential or potentially essential to normative deliverables may have been declared to ETSI. The declarations pertaining to these essential IPRs, if any, are publicly available for **ETSI members and non-members**, and can be found in ETSI SR 000 314: "*Intellectual Property Rights (IPRs); Essential, or potentially Essential, IPRs notified to ETSI in respect of ETSI standards*", which is available from the ETSI Secretariat. Latest updates are available on the ETSI Web server (<https://ipr.etsi.org/>).

Pursuant to the ETSI Directives including the ETSI IPR Policy, no investigation regarding the essentiality of IPRs, including IPR searches, has been carried out by ETSI. No guarantee can be given as to the existence of other IPRs not referenced in ETSI SR 000 314 (or the updates on the ETSI Web server) which are, or may be, or may become, essential to the present document.

## Trademarks

The present document may include trademarks and/or tradenames which are asserted and/or registered by their owners. ETSI claims no ownership of these except for any which are indicated as being the property of ETSI, and conveys no right to use or reproduce any trademark and/or tradename. Mention of those trademarks in the present document does not constitute an endorsement by ETSI of products, services or organizations associated with those trademarks.

**DECT™**, **PLUGTESTS™**, **UMTS™** and the ETSI logo are trademarks of ETSI registered for the benefit of its Members. **3GPP™** and **LTE™** are trademarks of ETSI registered for the benefit of its Members and of the 3GPP Organizational Partners. **oneM2M™** logo is a trademark of ETSI registered for the benefit of its Members and of the oneM2M Partners. **GSM®** and the GSM logo are trademarks registered and owned by the GSM Association.

---

## Legal Notice

This Technical Specification (TS) has been produced by ETSI 3rd Generation Partnership Project (3GPP).

The present document may refer to technical specifications or reports using their 3GPP identities. These shall be interpreted as being references to the corresponding ETSI deliverables. (2024-04)

The cross reference between 3GPP and ETSI identities can be found under <https://webapp.etsi.org/key/queryform.asp>.

---

## Modal verbs terminology

In the present document "**shall**", "**shall not**", "**should**", "**should not**", "**may**", "**need not**", "**will**", "**will not**", "**can**" and "**cannot**" are to be interpreted as described in clause 3.2 of the [ETSI Drafting Rules](#) (Verbal forms for the expression of provisions).

"**must**" and "**must not**" are **NOT** allowed in ETSI deliverables except when used in direct citation.

# Contents

Intellectual Property Rights .....	2
Legal Notice .....	2
Modal verbs terminology.....	2
Foreword.....	6
1 Scope .....	8
2 References .....	9
3 Definitions, symbols and abbreviations .....	12
3.1 Definitions .....	12
3.2 Symbols.....	13
3.3 Abbreviations .....	13
4 Applicability.....	14
4.1 Architecture .....	14
5 Profile Description .....	14
5.1 Profile Identification.....	14
5.2 Summary .....	14
5.3 Gateway Control Protocol Version .....	15
5.4 Connection model.....	15
5.5 Context attributes .....	15
5.6 Terminations.....	16
5.6.1 Termination names .....	16
5.6.1.1 IP Termination .....	16
5.6.1.1.1 ABNF Coding Overview and prose specification .....	16
5.6.1.1.2 ASN.1 Coding Overview and prose specification .....	16
5.6.2 Multiplexed terminations .....	17
5.7 Descriptors .....	17
5.7.1 TerminationState Descriptor .....	17
5.7.2 Stream Descriptor .....	18
5.7.2.0 General .....	18
5.7.2.1 LocalControl Descriptor.....	18
5.7.3 Events descriptor .....	19
5.7.4 EventBuffer descriptor.....	21
5.7.5 Signals descriptor.....	21
5.7.6 DigitMap descriptor .....	23
5.7.7 Statistics descriptor .....	23
5.7.8 ObservedEvents descriptor .....	23
5.7.9 Topology descriptor .....	23
5.7.10 Error descriptor .....	24
5.8 Command API.....	27
5.8.1 Add .....	27
5.8.2 Modify .....	27
5.8.3 Subtract.....	28
5.8.4 Move.....	28
5.8.5 AuditValue.....	28
5.8.6 AuditCapabilities .....	28
5.8.7 Notify.....	29
5.8.8 ServiceChange .....	29
5.8.9 Manipulating and auditing context attributes.....	31
5.9 Generic command syntax and encoding.....	31
5.10 Transactions .....	31
5.11 Messages .....	32
5.12 Transport .....	32
5.13 Security .....	33
5.14 Packages .....	33

5.14.1	Mandatory Packages .....	33
5.14.2	Optional Packages .....	35
5.14.3	Package usage information .....	37
5.14.3.1	Generic (g) .....	37
5.14.3.2	Base root (root) .....	38
5.14.3.3	Differentiated Services (ds).....	39
5.14.3.4	Gate Management (gm).....	39
5.14.3.5	Traffic management (tman).....	40
5.14.3.6	Inactivity Timer (it).....	41
5.14.3.7	IP Domain Connection (ipdc) .....	41
5.14.3.8	Media Gateway Overload Control Package (ocp).....	42
5.14.3.9	Hanging Termination Detection (hangterm) .....	42
5.14.3.10	Media Gateway Resource Congestion handling Package (chp) .....	43
5.14.3.11	IP Realm Availability (ipra).....	43
5.14.3.12	IP NAPT Traversal (ipnapt).....	44
5.14.3.13	RTCP Handling Package (rtcp).....	44
5.14.3.14	Application Data Inactivity Detection (adid) .....	45
5.14.3.15	Explicit Congestion Notification for RTP-over-UDP Support (ecnrous).....	45
5.14.3.16	MG Act-as STUN Server (mgastuns) .....	46
5.14.3.17	Originate STUN Continuity Check (ostuncc) .....	47
5.14.3.18	TCP basic connection control (tcpbcc) .....	48
5.14.3.19	TLS basic session control (tlbsc).....	48
5.14.3.20	Stream endpoint interlinkage (seplink) .....	49
5.14.3.21	MG located Bearer Level ALG (mgbalg) .....	50
5.14.3.22	STUN Consent Freshness (stnconfres).....	50
5.14.3.23	Media Grouping (mggroup) .....	51
5.14.3.24	SCTP basic connection control package (sctpbcc).....	52
5.14.3.25	SCTP Re-configuration Stream Reset (sctpreset) .....	52
5.15	Mandatory support of SDP and Annex C information elements .....	54
5.16	Optional support of SDP and Annex C information elements.....	57
5.17	Procedures .....	62
5.17.1	Formats and Codes .....	62
5.17.2	Call Related Procedures.....	68
5.17.2.1	General .....	68
5.17.2.2	Reserve AGW Connection Point.....	68
5.17.2.3	Configure AGW Connection Point .....	74
5.17.2.4	Reserve and Configure AGW Connection Point.....	82
5.17.2.5	Release AGW Termination .....	91
5.17.2.6	Termination Heartbeat Indication .....	91
5.17.2.7	IP Bearer Released .....	92
5.17.2.8	Media Inactivity Notification .....	92
5.17.2.9	Change Through Connection .....	93
5.17.2.10	Change Flow Direction .....	93
5.17.2.11	ECN Failure Indication .....	94
5.17.2.12	ICE Connectivity Check Result Notification .....	94
5.17.2.13	ICE New Peer Reflexive Candidate Notification.....	94
5.17.2.14	Notify TCP connection establishment Failure Indication .....	95
5.17.2.15	Notify (D)TLS session establishment Failure Indication .....	95
5.17.2.16	STUN Consent Freshness Test Failure Notification .....	96
5.17.2.17	Notify SCTP Stream Reset.....	96
5.17.2.18	Notify SCTP Stream Reset Result .....	97
5.17.3	Non-Call Related Procedures.....	97
5.17.3.1	General .....	97
5.17.3.2	IMS-AGW Out Of Service.....	98
5.17.3.3	IMS-AGW Communication Up .....	99
5.17.3.4	IMS-AGW Restoration .....	99
5.17.3.5	IMS-AGW Register .....	100
5.17.3.6	IMS-AGW Re-Register.....	100
5.17.3.7	IMS-ALG Ordered Re-register .....	101
5.17.3.8	IMS-ALG Restoration.....	101
5.17.3.9	IMS-ALG Out of Service.....	102
5.17.3.10	Audit Value .....	102

5.17.3.11	Command Rejected .....	104
5.17.3.12	AGW Capability Change .....	104
5.17.3.13	IMS-AGW Resource Congestion Handling – Activate.....	104
5.17.3.14	IMS-AGW Resource Congestion Handling – Indication.....	105
5.17.3.15	Inactivity Timeout – Activation .....	105
5.17.3.16	Inactivity Timeout – Indication.....	106
5.17.3.17	Realm Availability Change – Activation .....	106
5.17.3.18	Realm Availability Change – Indication .....	106
5.17.3.19	Termination Out Of Service.....	107
<b>Annex A (informative):</b>	<b>Change history .....</b>	<b>108</b>
History .....		110

**iTeh Standards**  
**(<https://standards.iteh.ai>)**  
**Document Preview**

[ETSI TS 129 334 V13.11.0 \(2024-04\)](https://standards.iteh.ai/catalog/standards/etsi/6d2b7457-1eb3-43cc-86c5-b723c860c147/etsi-ts-129-334-v13-11-0-2024-04)

<https://standards.iteh.ai/catalog/standards/etsi/6d2b7457-1eb3-43cc-86c5-b723c860c147/etsi-ts-129-334-v13-11-0-2024-04>

---

# Foreword

This Technical Specification has been produced by the 3rd Generation Partnership Project (3GPP).

The contents of the present document are subject to continuing work within the TSG and may change following formal TSG approval. Should the TSG modify the contents of the present document, it will be re-released by the TSG with an identifying change of release date and an increase in version number as follows:

Version x.y.z

where:

- x the first digit:
  - 1 presented to TSG for information;
  - 2 presented to TSG for approval;
  - 3 or greater indicates TSG approved document under change control.
- y the second digit is incremented for all changes of substance, i.e. technical enhancements, corrections, updates, etc.
- z the third digit is incremented when editorial only changes have been incorporated in the document.

In the present document, modal verbs have the following meanings:

- shall** indicates a mandatory requirement to do something
- shall not** indicates an interdiction (prohibition) to do something

The constructions "shall" and "shall not" are confined to the context of normative provisions, and do not appear in Technical Reports.

The constructions "must" and "must not" are not used as substitutes for "shall" and "shall not". Their use is avoided insofar as possible, and they are not used in a normative context except in a direct citation from an external, referenced, non-3GPP document, or so as to maintain continuity of style when extending or modifying the provisions of such a referenced document.

- should** indicates a recommendation to do something
- should not** indicates a recommendation not to do something
- may** indicates permission to do something
- need not** indicates permission not to do something

The construction "may not" is ambiguous and is not used in normative elements. The unambiguous constructions "might not" or "shall not" are used instead, depending upon the meaning intended.

- can** indicates that something is possible
- cannot** indicates that something is impossible

The constructions "can" and "cannot" are not substitutes for "may" and "need not".

- will** indicates that something is certain or expected to happen as a result of action taken by an agency the behaviour of which is outside the scope of the present document
- will not** indicates that something is certain or expected not to happen as a result of action taken by an agency the behaviour of which is outside the scope of the present document
- might** indicates a likelihood that something will happen as a result of action taken by some agency the behaviour of which is outside the scope of the present document

**might not** indicates a likelihood that something will not happen as a result of action taken by some agency the behaviour of which is outside the scope of the present document

In addition:

**is** (or any other verb in the indicative mood) indicates a statement of fact

**is not** (or any other negative verb in the indicative mood) indicates a statement of fact

The constructions "is" and "is not" do not indicate requirements.

**iTeh Standards**  
**(<https://standards.iteh.ai>)**  
**Document Preview**

[ETSI TS 129 334 V13.11.0 \(2024-04\)](https://standards.iteh.ai/catalog/standards/etsi/6d2b7457-1eb3-43cc-86c5-b723c860c147/etsi-ts-129-334-v13-11-0-2024-04)

<https://standards.iteh.ai/catalog/standards/etsi/6d2b7457-1eb3-43cc-86c5-b723c860c147/etsi-ts-129-334-v13-11-0-2024-04>

# 1 Scope

The present document describes the protocol to be used on the IMS Application Level Gateway (ALG) – IMS Access Gateway (IMS-AGW) interface. The basis for this protocol is the H.248 protocol as specified in ITU-T. The IMS architecture is described in 3GPP TS 23.228 [2]. The underlying reference model and stage 2 information is described in Annex G of 3GPP TS 23.228 [2] and in 3GPP TS 23.334 [23].

This specification describes the application of H.248 on the Iq interface (see Figure 1). Required extensions use the H.248 standard extension mechanism. In addition certain aspects of the base protocol H.248 are not needed for this interface and thus excluded by this profile.

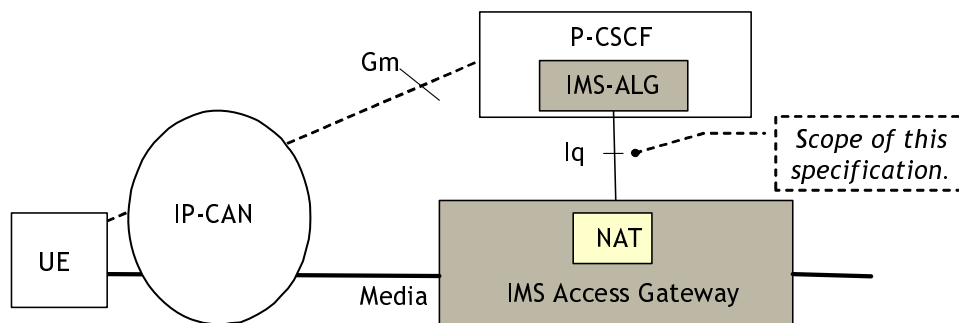

**Figure 1: Reference model for IMS access**

The reference model for the IMS-ALG and the IMS-AGW supporting the ATCF/ATGW function is shown in Figure 1a below.

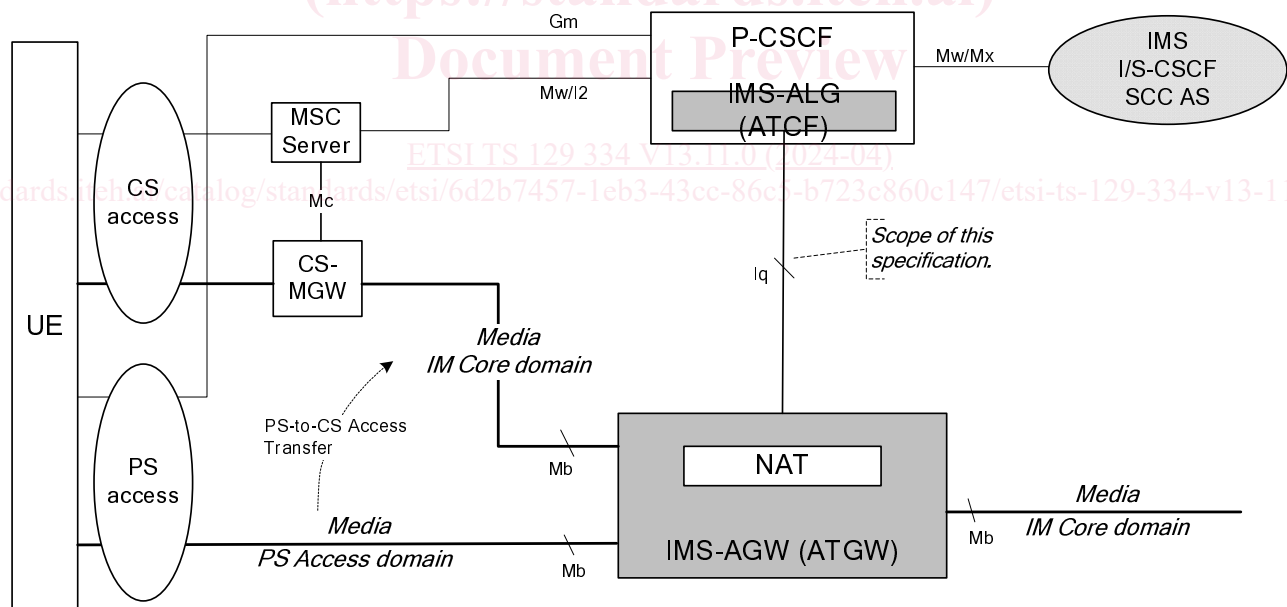

**Figure 1a: Reference model for IMS-ALG/IMS-AGW with ATCF/ATGW function**

See 3GPP TS 23.237 [38] clause 5.2 for a comprehensive description of the reference model.

The reference model for the P-CSCF enhanced for WebRTC (eP-CSCF) and the IMS-AGW enhanced for WebRTC (eIMS-AGW) to support WebRTC client access to IMS is shown in Figure 1b as below, see 3GPP TS 23.228 [2] Annex U for a comprehensive description of the reference model.

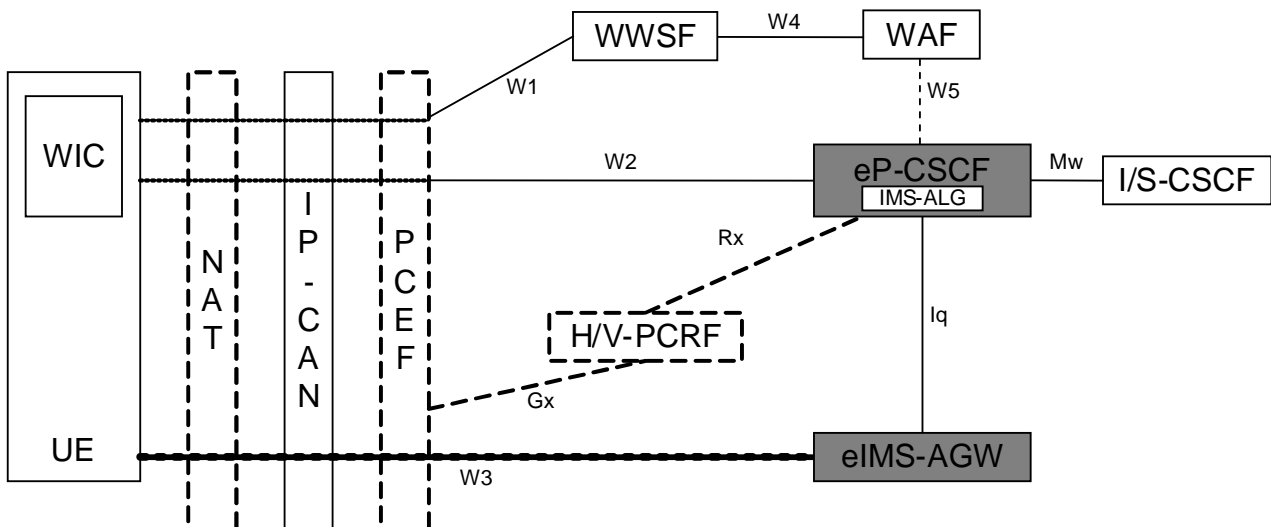

**Figure 1b: Reference Architecture for eP-CSCF/eIMS-AGW supporting WebRTC access to IMS**

NOTE: The presence of dashed elements in the figure depends on the configuration. PCC functional elements are present only for EPC access with QoS. The corresponding PCC elements for fixed access are also optionally supported but not shown. The NAT in figure 1b is meant for non-cellular access to IMS.

## 2 References

The following documents contain provisions which, through reference in this text, constitute provisions of the present document.

- References are either specific (identified by date of publication, edition number, version number, etc.) or non-specific.
- For a specific reference, subsequent revisions do not apply.
- For a non-specific reference, the latest version applies. In the case of a reference to a 3GPP document (including a GSM document), a non-specific reference implicitly refers to the latest version of that document *in the same Release as the present document*.

- [1] 3GPP TR 21.905: "Vocabulary for 3GPP Specifications".
- [2] 3GPP TS 23.228: "IP Multimedia Subsystem (IMS); Stage 2".
- [3] ETSI TS 183 018 V3.5.1 (2009-07): "Telecommunications and Internet converged Services and Protocols for Advanced Networking (TISPAN); Resource and Admission Control: H.248 Profile Version 3 for controlling Border Gateway Functions (BGF) in the Resource and Admission Control Subsystem (RACS); Protocol specification".
- [4] ITU-T Recommendation H.248.37 (06/2008): "Gateway control protocol: IP NAPT traversal package".
- [5] ITU-T Recommendation H.248.57 (10/2014): "Gateway control protocol: RTP Control Protocol Package".
- [6] ITU-T Recommendation H.248.43 (06/2008): "Gateway control protocol: Gate Management and Gate Control packages".
- [7] ITU-T Recommendation H.248.53 (03/2009): "Gateway control protocol: Traffic management packages".
- [8] ITU-T Recommendation H.248.41 Amendment 1 (06/2008): "Gateway control protocol: IP domain connection package: IP Realm Availability Package".

- [9] ITU-T Recommendation H.248.36 (09/2005): "Gateway control protocol: Hanging Termination Detection package".
- [10] ITU-T Recommendation H.248.1 (05/2002): "Gateway Control Protocol: Version 2" including the Corrigendum1 for Version 2 (03/04).
- [11] ITU-T Recommendation H.248.14 (03/2009): "Gateway control protocol: Inactivity timer package".
- [12] ITU-T Recommendation H.248.52 (06/2008): "Gateway control protocol: QoS support packages".
- [13] ITU-T Recommendation H.248.11 (11/2002): "Gateway control protocol: Media gateway overload control package".  
Inclusive Corrigendum 1 (06/2008) to H.248.11 " Gateway control protocol: Media gateway overload control package: Clarifying MG-overload event relationship to ADD commands".
- [14] ITU-T Recommendation H.248.10 (07/2001): "Media gateway resource congestion handling package".
- [15] IETF RFC 5234 (2008): "Augmented BNF for Syntax Specifications: ABNF".
- [16] IETF RFC 4960 (2007): "Stream control transmission protocol".
- [17] IETF RFC 4566 (2006): "SDP: Session Description Protocol".
- [18] IETF RFC 4975 (2007): "The Message Session Relay Protocol (MSRP)".
- [19] IETF RFC 3551 (2003): "RTP Profile for Audio and Video Conferences with Minimal Control".
- [20] IETF RFC 4145 (2005): "TCP-Based Media Transport in the Session Description Protocol (SDP)".
- [21] IETF RFC 3605 (2003): "Real Time Control Protocol (RTCP) attribute in Session Description Protocol (SDP)".
- [22] ITU-T Recommendation X.690 (11/2008): "ASN.1 encoding rules: Specification of Basic Encoding Rules (BER), Canonical Encoding Rules (CER) and Distinguished Encoding Rules (DER)".
- [23] 3GPP TS 23.334: "IMS Application Level Gateway (IMS-ALG) – IMS Access Gateway (IMS-AGW) interface: Procedures Descriptions".
- [24] ITU-T Recommendation H.248.40 (01/2007): "Gateway control protocol: Application Data Inactivity Detection package".
- [25] IETF RFC 4585 (2006): "Extended RTP Profile for Real-time Transport Control Protocol (RTCP) - Based Feedback (RTP/AVPF)".
- [26] 3GPP TS 26.114: "IP Multimedia Subsystem (IMS); Multimedia telephony; Media handling and interaction".
- [27] 3GPP TS 33.210: "Technical Specification Group Services and System Aspects;3G Security; Network Domain Security; IP Network Layer Security".
- [28] IETF RFC 3556 (2003): "Session Description Protocol (SDP) Bandwidth Modifiers for RTP Control Protocol (RTCP) Bandwidth".
- [29] IETF RFC 4568 (2006): "Session Description Protocol (SDP) Security Descriptions for Media Streams".
- [30] IETF RFC 3711 (2004): "The Secure Real-time Transport Protocol (SRTP)".
- [31] IETF RFC 5124 (2008): "Extended Secure RTP Profile for Real-time Transport Control Protocol (RTCP)-Based Feedback (RTP/SAVPF)".
- [32] IETF RFC 2216 (1997): "Network Element Service Specification Template".

- [33] Supplement 7 to ITU-T H-series Recommendations H.Sup7 (05/2008): "Gateway control protocol: Establishment procedures for the H.248 MGC-MG control association".
- [34] 3GPP TS 33.328: "IMS Media Plane Security".
- [35] Void
- [36] Void
- [37] Void
- [38] 3GPP TS 23.237: "IP Multimedia subsystem (IMS) Service Continuity; Stage 2".
- [39] 3GPP TS 22.153: "Multimedia Priority Service".
- [40] ITU-T Recommendation H.248.82 (03/2013): "Gateway control protocol: Explicit Congestion Notification Support".
- [41] IETF RFC 5285 (2008): "A General Mechanism for RTP Header Extensions".
- [42] IETF RFC 6236: "Negotiation of Generic Image Attributes in the Session Description Protocol (SDP)".
- [43] ITU-T Recommendation H.248.50 (07/2016): "Gateway control protocol: NAT traversal toolkit packages".
- [44] IETF RFC 5245: "Interactive Connectivity Establishment (ICE): A Protocol for Network Address Translator (NAT) Traversal for Offer/Answer Protocols".
- [45] 3GPP TS 24.229: "IP Multimedia Call Control Protocol based on SIP and SDP".
- [46] ITU-T Recommendation H.248.84 (07/2012): "Gateway control protocol: NAT traversal for peer-to-peer services".
- [47] ITU-T Recommendation H.248.89 (10/2014): "Gateway control protocol: TCP support packages".
- [48] ITU-T Recommendation H.248.90 (10/2014): "Gateway control protocol: ITU-T H.248 packages for control of transport security using transport layer security (TLS)".
- [49] ITU-T Recommendation H.248.92 (10/2014): "Gateway control protocol: Stream endpoint interlinkage package".
- [50] ITU-T Recommendation H.248.93 (10/2014): "Gateway control protocol: ITU-T H.248 support for control of transport security using the datagram transport layer security (DTLS) protocol".
- [51] IETF RFC 793: "Transmission Control Protocol – DARPA Internet Program – Protocol Specification".
- [52] IETF RFC 4582: "The Binary Floor Control Protocol (BFCP)".
- [53] IETF RFC 5246: "The Transport Layer Security (TLS) Protocol Version 1.2".
- [54] Void
- [55] IETF RFC 8122: "Connection-Oriented Media Transport over the Transport Layer Security (TLS) Protocol in the Session Description Protocol (SDP)".
- [56] ITU-T Recommendation H.248.78 (11/2015): "Gateway control protocol: Bearer-level message backhauling and application level gateway".
- [57] IETF RFC 6714: "Connection Establishment for Media Anchoring (CEMA) for the Message Session Relay Protocol (MSRP)".
- [58] IETF RFC 7675: "Session Traversal Utilities for NAT (STUN) Usage for Consent Freshness".
- [59] IETF RFC 5761: "Multiplexing RTP Data and Control Packets on a Single Port".

- [60] IETF RFC 5763: "Framework for Establishing a Secure Real-time Transport Protocol (SRTP) Security Context Using Datagram Transport Layer Security (DTLS)".
- [61] IETF RFC 5764: "Datagram Transport Layer Security (DTLS) Extension to Establish Keys for the Secure Real-time Transport Protocol (SRTP)".
- [62] IETF RFC 4573: "MIME Type Registration for RTP Payload Format for H.224".
- [63] ITU-T Recommendation H.224 (01/2005): "A real time control protocol for simplex applications using the H.221 LSD/HSD/MLP channels".
- [64] ITU-T Recommendation H.281 (11/1994): "A far end camera control protocol for videoconferences using H.224".
- [65] ITU-T Recommendation H.248.96 (11/2015): "Gateway control protocol: H.248 support for control of SCTP bearer connections".
- [66] ITU-T Recommendation H.248.97 (11/2015): "Gateway control protocol: H.248 support for control of SCTP bearer connections".
- [67] ITU-T Recommendation H.248.94 (11/2015): "Gateway control protocol: Web-based real-time communication services – H.248 protocol support and profile guidelines".
- [68] IETF RFC 8841: "Session Description Protocol (SDP) Offer/Answer Procedures for Stream Control Transmission Protocol (SCTP) over Datagram Transport Layer Security (DTLS) Transport".
- [69] IETF RFC 8864: "Negotiation Data Channels Using the Session Description Protocol (SDP)".
- [70] IETF RFC 8873: "Message Session Relay Protocol (MSRP) over Data Channels".
- [71] ITU-T Recommendation H.248.88 (01/2014): "Gateway control protocol: RTP topology dependent RTCP handling by ITU-T H.248 media gateways with IP terminations".
- [72] IETF RFC 5939: "Session Description Protocol (SDP) Capability Negotiation".
- [73] ITU-T Recommendation H.248.80 (01/2014): "Gateway control protocol: Usage of the revised SDP offer/answer model with ITU-T H.248".

---

## 3 Definitions, symbols and abbreviations

### 3.1 Definitions

For the purposes of the present document, the following terms and definitions apply.

**Address:** term used for "network address" (IP address)

**End-to-access edge security:** media protection extending between an IMS UE and the first IMS core network node in the media path without being terminated by any intermediary node.

**Port:** term used for "transport port" (L4 port).

**Transcoding:** transcoding in general is the translation from one type of encoded media format to another different media format, e.g. G.711 A-law to  $\mu$ -law or vice versa, G.729 to AMR with 4.75 rate.

NOTE 1: The definition of "transcoding" is according clause 3.10 of ITU-T Recommendation V.152 [23].

NOTE 2: Transcoding belongs to the category of "media aware" IP-to-IP interworking.

**Transparent Forwarding:** media gateway packet forwarding behaviour with the characteristic of Lx-PDU integrity. This is a unidirectional characteristic of an Lx-PDU flow.

NOTE 3: The definition is according clause 3.2.10 of ITU-T Recommendation H.248.88 [71].

NOTE 4: The semantic covers both traffic directions when applied on H.248 Streams (due to their inherent characteristic of bidirectionality).

**Transport Address:** term used for the combination of a *Network Address* and a *Transport Port*.

For the purposes of the present document, the following terms and definitions as defined in 3GPP TS 23.334 [23] apply:

**ICE lite**

**Full ICE.**

## 3.2 Symbols

For the purposes of the present document, the following symbols apply:

Iq                      Interface between the IMS Application Level Gateway (ALG) (IMS-ALG) and the IMS Access Gateway (IMS-AGW)

## 3.3 Abbreviations

For the purposes of the present document, the abbreviations defined in 3GPP TR 21.905 [1] apply, with the following additions. An abbreviation defined in the present document takes precedence over the definition of the same abbreviation, if any, in 3GPP TR 21.905 [1].

ABNF	Augmented Backus-Naur Form
ATCF	Access Transfer Control Function
ATGW	Access Transfer Gateway
B-ALG	Bearer Level Application-Level Gateway
BFCP	Binary Floor Control Protocol
CVO	Coordination of Video Orientation
DSCP	Differentiated Service Code Point
e2ae	End-to-Access-Edge (security model)
ECN	Explicit Congestion Notification
eIMS-AGW	IMS Access Gateway enhanced for WebRTC
eP-CSCF	P-CSCF enhanced for WebRTC
FECC	Far End Camera Control
ICE	Interactive Connectivity Establishment
IMS-AGW	IMS Access Gateway
IMS-ALG	IMS Application Level Gateway
IP	Internet Protocol
LD	Local Descriptor (H.248 protocol element)
MG	Media Gateway
MGC	Media Gateway Controller
MPS	Multimedia Priority Service
MSRP	Message Session Relay Protocol
NA	Not Applicable
NAPT	Network Address and Port Translation
NAPT-PT	NAPT and Protocol Translation
NAT	Network Address Translation
RD	Remote Descriptor (H.248 protocol element)
ROI	Region of Interest
RTCP	RTP Control Protocol
SCTP	Stream Control Transport Protocol
SDP	Session Description Protocol
SDPCapNeg	SDP Capability Negotiation
SRVCC	Single Radio Voice Call Continuity
STUN	Session Traversal Utilities for NAT
TCP	Transmission Control Protocol
TLS	Transport Layer Security (protocol)
ToS	Type-of-Service