

DRAFT INTERNATIONAL STANDARD

ISO/DIS 19206-3

ISO/TC 22/SC 33

Secretariat: DIN

Voting begins on:
2020-05-08

Voting terminates on:
2020-07-31

Road vehicles — Test devices for target vehicles, vulnerable road users and other objects, for assessment of active safety functions —

Part 3: Requirements for passenger vehicle 3D targets

Véhicules routiers — Dispositifs d'essai pour véhicules cibles, usagers de la route vulnérables et autres objets, pour l'évaluation de fonctions de sécurité active —

Partie 3: Exigences pour cibles de véhicules particuliers 3D

ICS: 43.020

iTeh STANDARD PREVIEW
(standards.iteh.ai)

[ISO/DIS 19206-3](https://standards.iteh.ai/catalog/standards/sist/db9169a7-9bc8-4d95-a3d1-522a780a2f51/iso-dis-19206-3)

<https://standards.iteh.ai/catalog/standards/sist/db9169a7-9bc8-4d95-a3d1-522a780a2f51/iso-dis-19206-3>

THIS DOCUMENT IS A DRAFT CIRCULATED FOR COMMENT AND APPROVAL. IT IS THEREFORE SUBJECT TO CHANGE AND MAY NOT BE REFERRED TO AS AN INTERNATIONAL STANDARD UNTIL PUBLISHED AS SUCH.

IN ADDITION TO THEIR EVALUATION AS BEING ACCEPTABLE FOR INDUSTRIAL, TECHNOLOGICAL, COMMERCIAL AND USER PURPOSES, DRAFT INTERNATIONAL STANDARDS MAY ON OCCASION HAVE TO BE CONSIDERED IN THE LIGHT OF THEIR POTENTIAL TO BECOME STANDARDS TO WHICH REFERENCE MAY BE MADE IN NATIONAL REGULATIONS.

RECIPIENTS OF THIS DRAFT ARE INVITED TO SUBMIT, WITH THEIR COMMENTS, NOTIFICATION OF ANY RELEVANT PATENT RIGHTS OF WHICH THEY ARE AWARE AND TO PROVIDE SUPPORTING DOCUMENTATION.

This document is circulated as received from the committee secretariat.



Reference number
ISO/DIS 19206-3:2020(E)

© ISO 2020

iTeh STANDARD PREVIEW
(standards.iteh.ai)

ISO/DIS 19206-3

<https://standards.iteh.ai/catalog/standards/sist/db9169a7-9bc8-4d95-a3d1-522a780a2f51/iso-dis-19206-3>



COPYRIGHT PROTECTED DOCUMENT

© ISO 2020

All rights reserved. Unless otherwise specified, or required in the context of its implementation, no part of this publication may be reproduced or utilized otherwise in any form or by any means, electronic or mechanical, including photocopying, or posting on the internet or an intranet, without prior written permission. Permission can be requested from either ISO at the address below or ISO's member body in the country of the requester.

ISO copyright office
CP 401 • Ch. de Blandonnet 8
CH-1214 Vernier, Geneva
Phone: +41 22 749 01 11
Fax: +41 22 749 09 47
Email: copyright@iso.org
Website: www.iso.org

Published in Switzerland

Contents

Page

Foreword	v
Introduction	vi
1 Scope	1
2 Normative references	1
3 Terms and definitions	1
4 Symbols and abbreviated terms	4
5 Vehicle target specifications	4
5.1 Vehicle classes and target applicability.....	4
5.2 Reference dimensional measurements.....	4
5.3 Safety considerations.....	4
5.4 Repairability.....	4
5.5 Environmental conditions.....	5
5.6 Reference coordinate system.....	5
5.7 Speed classes.....	5
6 Vehicle target response to sensing technologies	6
6.1 General.....	6
6.2 Optical requirements.....	6
6.2.1 General.....	6
6.2.2 Reference measurements.....	6
6.2.3 Stability of dimensions for optical recognition.....	6
6.2.4 Viewing angles.....	6
6.2.5 Features related to optical requirements.....	7
6.3 Radar requirements.....	7
6.3.1 Reference measurements of radar properties.....	7
6.3.2 Reference measurements.....	8
6.3.3 Radar cross section, static measurements and requirements.....	8
6.3.4 Radar recognition features of vehicle target.....	8
6.3.5 Stability of dimensions for radar recognition.....	8
6.4 Thermal requirements for Far Infrared vision systems.....	8
6.4.1 General.....	8
6.4.2 Reference measurements.....	8
6.4.3 Thermal characteristics.....	8
6.5 Calibration.....	9
6.6 Field verification.....	9
7 Motion and positioning during test for VT including target carrier system	9
7.1 General requirements.....	9
7.2 Longitudinal positioning.....	9
7.2.1 Speed range for operation.....	9
7.2.2 Accelerations.....	9
7.3 Lateral positioning.....	9
7.3.1 General.....	9
7.3.2 Yaw rate.....	10
7.3.3 Lateral position.....	10
7.3.4 Lateral acceleration.....	10
7.3.5 Turning diameter.....	10
7.4 Vertical positioning.....	10
7.4.1 General.....	10
7.4.2 Pitch angle.....	10
7.4.3 Vertical motions.....	10
Annex A (informative) Vehicle classes and dimensions	11

Annex B (normative) Visual and near infrared sensor-specific recognition properties and measurements	15
Annex C (normative) Radar-specific recognition properties and measurements	20
Annex D (normative) Measurement of position, speed and acceleration of the vehicle target	44
Annex E (informative) Field verification of vehicle target properties	45
Bibliography	46

iTeh STANDARD PREVIEW
(standards.iteh.ai)

[ISO/DIS 19206-3](https://standards.iteh.ai/catalog/standards/sist/db9169a7-9bc8-4d95-a3d1-522a780a2f51/iso-dis-19206-3)

<https://standards.iteh.ai/catalog/standards/sist/db9169a7-9bc8-4d95-a3d1-522a780a2f51/iso-dis-19206-3>

Foreword

ISO (the International Organization for Standardization) is a worldwide federation of national standards bodies (ISO member bodies). The work of preparing International Standards is normally carried out through ISO technical committees. Each member body interested in a subject for which a technical committee has been established has the right to be represented on that committee. International organizations, governmental and non-governmental, in liaison with ISO, also take part in the work. ISO collaborates closely with the International Electrotechnical Commission (IEC) on all matters of electrotechnical standardization.

The procedures used to develop this document and those intended for its further maintenance are described in the ISO/IEC Directives, Part 1. In particular, the different approval criteria needed for the different types of ISO documents should be noted. This document was drafted in accordance with the editorial rules of the ISO/IEC Directives, Part 2 (see www.iso.org/directives).

Attention is drawn to the possibility that some of the elements of this document may be the subject of patent rights. ISO shall not be held responsible for identifying any or all such patent rights. Details of any patent rights identified during the development of the document will be in the Introduction and/or on the ISO list of patent declarations received (see www.iso.org/patents).

Any trade name used in this document is information given for the convenience of users and does not constitute an endorsement.

For an explanation of the voluntary nature of standards, the meaning of ISO specific terms and expressions related to conformity assessment, as well as information about ISO's adherence to the World Trade Organization (WTO) principles in the Technical Barriers to Trade (TBT), see www.iso.org/iso/foreword.html.

This document was prepared by Technical Committee ISO/TC 22, *Road vehicles*, Subcommittee SC 33, *Vehicle dynamics and chassis components*, Working Group 16, *Active safety test equipment*.

A list of all parts in the ISO 19206 series can be found on the ISO website.

Any feedback or questions on this document should be directed to the user's national standards body. A complete listing of these bodies can be found at www.iso.org/members.html.

Introduction

ADAS (Advanced Driver Assistance Systems) and Active Safety systems are designed to support decision-making for the driver, extend the driver's awareness of the traffic situation with advanced warnings, improve the behaviour of the vehicle, and even take over vehicle control in an emergency situation. The goal is to completely avoid an accident or at least reduce the severity of an accident.

The surrogate target is an essential component in the evaluation of ADAS/active safety functions and different levels of automated driving systems, in all situations where a collision with the target may occur.

The characteristics of targets need to be trustworthy and a vehicle target needs to be recognized as a real vehicle by the various sensing technologies.

This document addresses the specification of vehicle 3D test targets.

A surrogate vehicle target needs to represent a real vehicle in terms of detectability and movement from all directions. It should also provide safety for the subject vehicle and test operators in the event that contact is made between the subject vehicle and the target. Crashworthiness and durability requirements for the vehicle target require that the material and construction of the vehicle target are adapted to fit the purposes.

Test cases usually address both stationary and moving targets and, as such, the physical construction of the target accommodates a target carrier system capable of mimicking realistic motions. This document includes requirements on the target carrier system as applicable.

Targets described in this document series may be used for system development or applied in conjunction with existing standards, or standards under development, for assessment of ADAS and active safety functions of vehicles.

iTeh STANDARD PREVIEW
(standards.iteh.ai)
<https://standards.iteh.ai/catalog/standards/sist/db9169a7-9bc8-4d95-a3d1-522a780a2f51/iso-dis-19206-3>

Road vehicles — Test devices for target vehicles, vulnerable road users and other objects, for assessment of active safety functions —

Part 3: Requirements for passenger vehicle 3D targets

1 Scope

This document specifies performance requirements for surrogate targets used to assess the system detection and performance of active safety systems.

This part of ISO 19206 specifies the properties of an omni-directional multi-purpose vehicle target for assessment of interaction in a variety of traffic scenarios.

The document specifies the properties of a vehicle target that will allow it to represent a passenger vehicle in terms of size, shape, reflection properties, etc. for testing purposes. The document addresses the detection requirements for a vehicle target in terms of sensing technologies commonly in use at the time of publication of this document, and where possible, anticipated future sensing technologies. It also addresses methodologies to verify the target response properties to these sensors, as well as performance requirements for the target carrier.

The vehicle targets specified in this document reflect passenger cars and in particular the smaller and more common B and C segment cars.

This document does not address the test procedures in terms of speeds, positions, or timing of events. Performance criteria for the active safety system are also not addressed.

2 Normative references

The following documents, in whole or in part, are normatively referenced in this document and are indispensable for its application. For dated references, only the edition cited applies. For undated references, the latest edition of the referenced document (including any amendments) applies.

ISO 8855:2011, *Road vehicles — Vehicle dynamics and road-holding ability — Vocabulary*

ISO 8608:2016, *Mechanical vibration — Road surface profiles — Reporting of measured data*

3 Terms and definitions

For the purposes of this document, the terms and definitions given in ISO 8855 and the following apply.

ISO and IEC maintain terminological databases for use in standardization at the following addresses:

- ISO Online browsing platform: available at <http://www.iso.org/obp>
- IEC Electropedia: available at <http://www.electropedia.org/>

3.1

subject vehicle (SV)

vehicle with active safety system to be tested

**3.2
vehicle target (VT)**

test device representing a vehicle, whose purpose is to activate sensor systems

Note 1 to entry: Vehicle target consists of a target structure and optionally a target carrier.

Note 2 to entry: This document addresses test devices representing a vehicle having the necessary features to be recognised from any direction (3D vehicle target).

**3.2.1
target structure**

physical structure whose purpose is to maintain the shape and provide the relevant sensor signature representing a vehicle

**3.2.2
target carrier**

mechanical system used to move and/or support the target structure according to a test protocol

Note 1 to entry: Target carrier may be self-contained within, or supporting the target structure or external devices connected with cables, beams, or similar structures.

Note 2 to entry: Target structure and target carrier may be integrated.

Note 3 to entry: Target structure fixation is included in the target carrier.

**3.3
target axis system
(X_t, Y_t, Z_t)**

axis system fixed in the reference frame of the target, so that the X_t axis is substantially horizontal and forwards (with the target at rest), and is parallel to the target's longitudinal plane of symmetry, and the Y_t axis is perpendicular to the target's longitudinal plane of symmetry and points to the left with the Z_t axis pointing upward

iTeh STANDARD PREVIEW
(standards.iteh.ai)
ISO/DIS 19206-3
<https://standards.iteh.ai/catalog/standards/sist/db9169a7-9bc8-4d95-a3d1-522a780a2f51/iso-dis-19206-3>

Note 1 to entry: See [Figure 2](#).

**3.4
target coordinate system
(x_t, y_t, z_t)**

coordinate system based on the target axis system with the origin located at the target reference point

**3.5
target reference point**

a point whose location relative to the external dimensions of the target, in its initial condition, remains constant

Note 1 to entry: to entry:

$x=0, y=0$ at the centroid of the area defined by a horizontal projection of the plan view of the target

$z=0$ at the ground plane

**3.6
measurement equipment**

equipment used to record the position and motions of the vehicle target relative to the subject vehicle to ensure that the test protocol is followed within prescribed tolerances and to record data documenting the function of the active safety system and allowing its performance to be assessed

**3.7
planned path**

the X,Y coordinates that define the desired trajectory of the target vehicle

3.8**lateral path deviation**

position error of the target vehicle relative to the planned path measured perpendicular from the planned path direction

Note 1 to entry: See illustration in [Figure 1](#).

Note 2 to entry: Y_G and X_G are the ground (fixed) coordinate axes in which the planned path is defined.

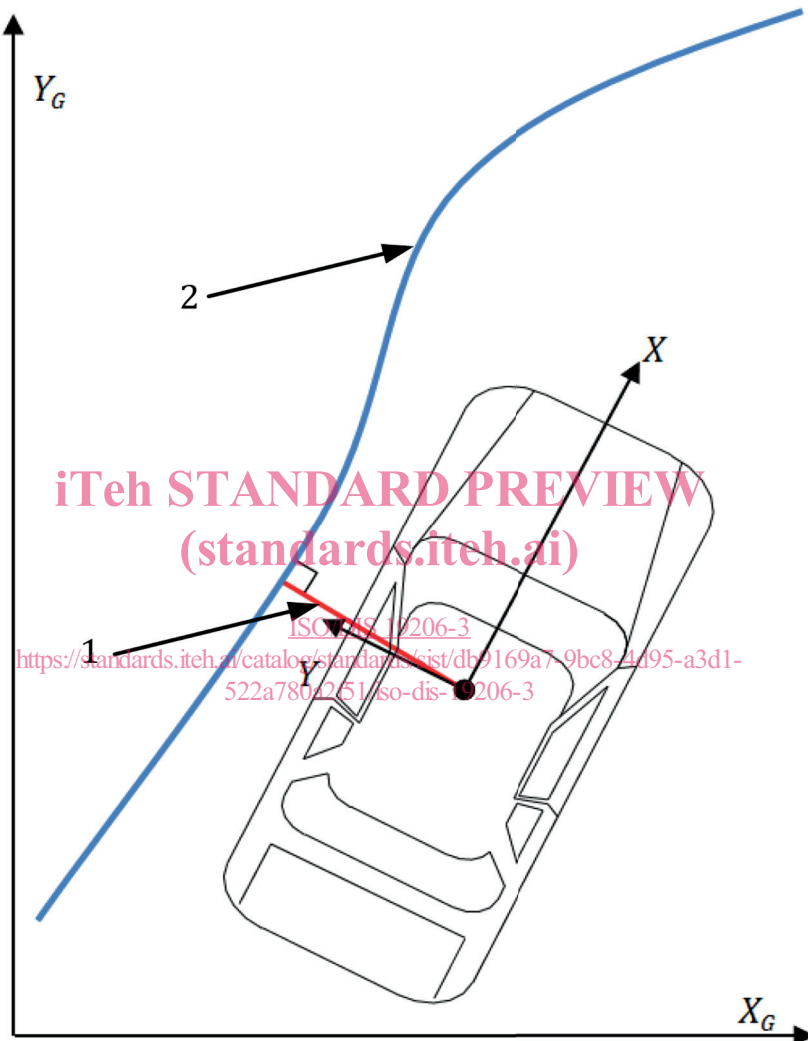
**Key**

- 1 Lateral path deviation
- 2 Planned path

Figure 1 — Lateral path deviation

4 Symbols and abbreviated terms

CCD	Charge-Coupled Device
CMOS	Complementary Metal Oxide Semiconductor
FIR	Far Infrared
LIDAR	Light Detection and Ranging
NIR	Near Infrared
PMD	Photonic Mixer Device
RCS	Radar Cross Section
SV	Subject Vehicle
VT	Vehicle Target

5 Vehicle target specifications

5.1 Vehicle classes and target applicability

The vehicle targets specified in this document reflect passenger cars and in particular the smaller and more common B and C segment cars. See [Annex A](#) for more information.

The test devices described in this document are intended for testing of systems designed to mitigate or avoid collisions in which the subject vehicle approaches the target vehicle from any direction.

5.2 Reference dimensional measurements

Reference measurements for the vehicle target should come from a representative sample of vehicles from the B/C segment that were manufactured within five years prior to the publication date of this document.

General dimensions of the vehicle fleet are given in [Annex A](#).

5.3 Safety considerations

Drivers of the subject vehicle shall not be exposed to any substantial risk of personal injury. The vehicle target and its components should not cause more than cosmetic damage to the subject vehicle when struck at a relative velocity of 60 km/h. The conditions specified by the test procedure application shall be taken into consideration.

NOTE Test procedures for specific applications typically indicate what measures are taken to reduce the risk of injury and vehicle damage. These measures can include instructions to disable subject vehicle systems such as supplementary occupant restraints, seatbelt pre-tensioners, vulnerable user protection systems, etc.

5.4 Repairability

The vehicle target should be easily reassembled or repaired after contacts. Field repairs should be possible to perform with standard hand tools. The sensor-specific characteristics shall be met also after re-assembly and repair. The time for reassembly is affected by the handling efficiency of the users and should be as short as possible. As a guideline the reassembly should be possible with two persons and should take less than 15 minutes. The target requirements should be fulfilled after at least fifty crashes with a relative velocity of 60 km/h with a vehicle of category M1.

NOTE 1 This requirement does not apply to disposable and single impact targets.

NOTE 2 Category M1: Vehicles designed and constructed for the carriage of passengers and comprising no more than eight seats in addition to the driver's seat. (Source: UN consolidated resolution R.E.3 and Directive 2007/46/EC).

5.5 Environmental conditions

The vehicle target shall fulfil all requirements in an ambient temperature range of -5 °C to $+40\text{ °C}$. The vehicle target shall not deteriorate under storage temperatures in the range of -40 °C to $+80\text{ °C}$ when properly stored.

NOTE The specified temperature range recognises that there are substantial technical challenges achieving a cost-effective target fulfilling the requirements at lower temperatures than -5 °C .

5.6 Reference coordinate system

The reference coordinate system in this document essentially adopts the coordinate system given in ISO 8855, adapting it to the purpose of the target vehicle movement. See [Figure 2](#) and applicable terms defined in [clause 3](#).

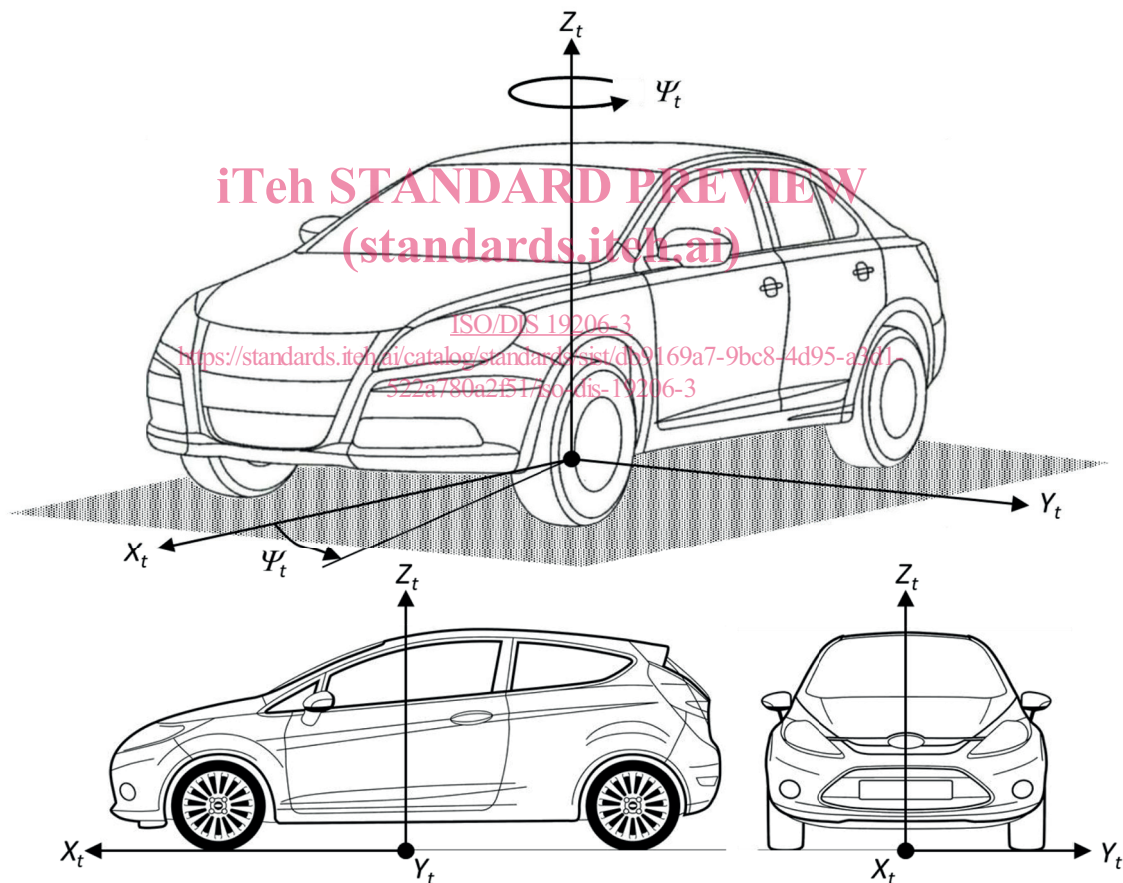

NOTE ψ_t is the rotation about the Z_t axis.

Figure 2 — Reference coordinate system

5.7 Speed classes

The following speed classes are applicable according to this document, see [Table 1](#):

Table 1 — Speed classes

Speed class	Description
SC50	Operational speed up to 50 km/h (13,9 m/s)
SC80	Operational speed up to 80 km/h (22,2 m/s)
SC80+	Operational speed up to and greater than 80 km/h (22,2 m/s)

6 Vehicle target response to sensing technologies

6.1 General

Requirements related to sensing technologies commonly in use at the time of publication of this document are listed in 6.2, 6.3 and 6.4. A vehicle target intended for use with a specific set of sensing technologies only needs to meet the requirements of those technologies.

6.2 Optical requirements

6.2.1 General

Sensors operating on optical principles include CCD and CMOS camera sensors, stereo camera sensors, Photonic Mixer Devices (PMD) and Light Detection and Ranging (LIDAR). These systems cover visible and near infrared light frequency spectra. PMD and LIDAR are more reliant on infrared reflectivity of the target surface.

6.2.2 Reference measurements (standards.iteh.ai)

When technology-specific measurements are required, information of the type of sensor used, environmental conditions during measurements, and date of measurement shall be provided with the description of the vehicle models. The version of the vehicle target and the target carrier shall be traceable to manufacturing drawings or supplier specifications.

General dimensions of the vehicle fleet are given in [Annex A](#).

6.2.3 Stability of dimensions for optical recognition

Target surface shall not flutter or vibrate unrealistically due to aerodynamic effects for the applicable speed class and a side wind of up to 5 m/s. Local fluttering should not exceed 10 mm perpendicularly from the reference surface. Distortion of the vehicle shape should not exceed 25 mm in any direction.

6.2.4 Viewing angles

Main angles for recognition are shown in [Figure 3](#).

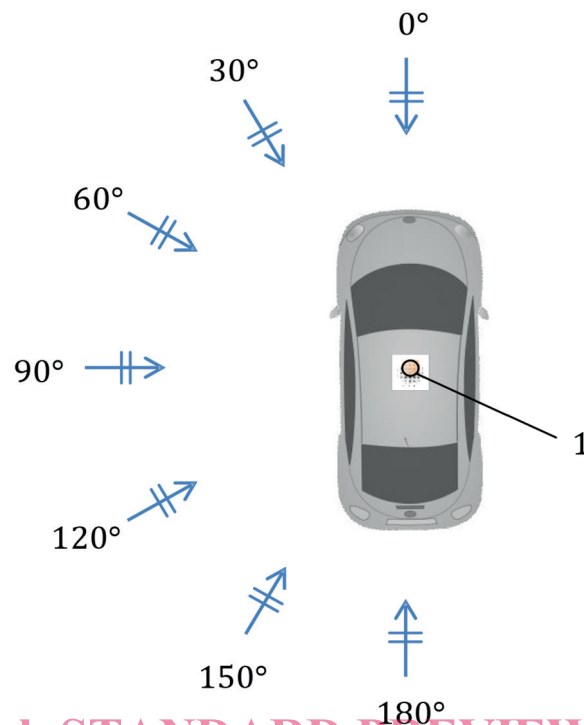

iTeh STANDARD PREVIEW
(standards.iteh.ai)

Key

1 Target reference point

ISO/DIS 19206-3
<https://standards.iteh.ai/catalog/standards/sist/db9165a7-96c8-4d95-a3d1-522a780a2f51/iso-dis-19206-3>
Figure 3 — Viewing angles

6.2.5 Features related to optical requirements

The visual difference between the VT and a passenger vehicle of the B/C segment size should be as small as possible. The contours of the VT should be representative of a real middle-sized passenger car. It should demonstrate a high level of symmetry about the x-z plane.

The wheels, consisting of tire and rim, shall be round and of realistic dimensions.

The windows (windscreen, side windows, rear window) should give the impression of being transparent. The interior of a real car (seat, steering wheel, rear view mirror, driver) may be indicated.

Features representing the rear lights, reflectors, and registration plate are required.

NOTE General requirements for the size and position of these features are available in e.g. [407/2011/EC](#), [UN-ECE R3](#), [UN-ECE R48](#), [FMVSS 108](#).

Lighter colours of vehicle targets shall be used. High contrast to background should be considered.

Features necessary for the optical recognition as specified in [Annex B](#) shall be followed.

6.3 Radar requirements

6.3.1 Reference measurements of radar properties

At the time of publication of this document, automotive applications of radar are using 24 GHz and 76 – 81 GHz.

6.3.2 Reference measurements

Reference measurements for the vehicle target should come from a representative sample of vehicles from the B/C segment that were manufactured within five years prior to the publication date of this document.

When technology-specific measurements are required, information of the type of sensor used, environmental conditions during measurements, and date of measurement shall be provided with the description of the vehicle models. The version of the vehicle target and the target carrier shall be traceable to manufacturing drawings or supplier specifications.

6.3.3 Radar cross section, static measurements and requirements

Measurement of radar cross section as described in [Annex C](#) shall be followed.

6.3.4 Radar recognition features of vehicle target

Features necessary for radar recognition as specified in [Annex C](#) shall be followed.

6.3.5 Stability of dimensions for radar recognition

Local fluttering due to aerodynamic effects should not cause radar signature to vary, including micro-Doppler effects, for the applicable speed class and a side wind of up to 5 m/s.

6.4 Thermal requirements for Far Infrared vision systems

6.4.1 General

The vehicle target is defined as possessing the optical characteristics according to [clause 6.2](#) with features added to provide response to thermal sensing. Inclusion of passive thermal sensor requirements is optional.

Far Infrared (FIR) vision systems can provide information to active safety systems in conditions of low light or otherwise limited visibility. A thermal camera detects far-infrared electromagnetic radiation with a wavelength in the range of 8 μm to 14 μm . Imaging is provided by means of an appropriate camera.

6.4.2 Reference measurements

When technology-specific measurements are required, information of the type of sensor used, environmental conditions during measurements, and date of measurement shall be provided with the description of the measured subjects and/or target. The version of the target and the target carrier shall be traceable to manufacturing drawings or supplier specifications.

6.4.3 Thermal characteristics

Vehicle targets commonly in use at the time of publication of this document do not feature vehicle-specific FIR characteristics. Developers of vehicle targets that incorporate such characteristics should ensure that the characteristics are comparable to typical vehicles represented by the target.

Characterization of these properties should follow the steps below:

- 1) Measurement of typical vehicles,
- 2) Establishment of boundaries,
- 3) Verification that the vehicle target FIR measurements are within the specified boundaries.

6.5 Calibration

The vehicle target manufacturer shall provide a certificate detailing which test information has been used to verify the product performance and which sensor technologies it conforms to. Target should comply to this document with a certificate.

Calibration shall be based on representative characteristics of the applied detection technology as described in [clauses 6.2, 6.3](#) and [6.4](#), and the related Annexes.

6.6 Field verification

For field verification of vehicle target functionality, see [Annex E](#) (informative).

7 Motion and positioning during test for VT including target carrier system

7.1 General requirements

The target carrier system shall be capable of positioning the target within tolerances required by the test procedure application. Repeatable test performance requires that subject and vehicle target relative speed and position must be consistent between test repetitions. Unless more stringent requirements are needed by a specific test procedure, the positioning requirements outlined in this section are the minimum requirements for the vehicle target. Recommendations for measurement equipment are given in [Annex D](#).

The following requirements should be fulfilled by the target carrier system:

- All visible parts of the target carrier system should be coloured to minimize the contrast with background, e.g. grey, to approximate the test area road surface. In case of a uniform background the colour shade of the background can be used; <https://standards.iteh.ai/catalog/standards/sist/db9169a7-9bc8-4d95-a3d1-522a780a8131/iso-19206-3>
- The target carrier system and resulting motion of the vehicle target shall minimally affect target characteristics (radar, optical signature, etc);
- The target carrier shall accelerate and decelerate in a smooth manner, except for actions intended to avoid impact or damage.

The requirements in this clause are applicable to all speed ranges. The positioning requirements in [7.2](#) and [7.3](#) are with reference to a coordinate system oriented with the vehicle target. The longitudinal axis is parallel with the direction of travel, see [Figure 2](#).

7.2 Longitudinal positioning

7.2.1 Speed range for operation

The steady state speed control accuracy shall be ± 1 km/h ($\pm 0,3$ m/s) for the speed classes in [Table 1](#).

7.2.2 Accelerations

Deceleration/braking of at least 6 m/s^2 is required. Acceleration of at least 1 m/s^2 is recommended.

7.3 Lateral positioning

7.3.1 General

The vehicle target shall be able to meet the lateral positioning requirements in [7.3.2](#) and [7.3.3](#) while operating in the speed range defined in [7.2.1](#) over a smooth road surface no rougher than road class A as defined in ISO 8608.