

---

---

**Connections for hydraulic fluid power  
and general use — Ports and stud  
ends with ISO 261 metric threads and  
O-ring sealing —**

Part 1:

**Ports with truncated housing for  
O-ring seal**

(standards.iteh.ai)

*Raccordements pour transmissions hydrauliques et applications  
générales — Orifices et éléments mâles à filetage métrique ISO 261 et  
joint torique —*

<https://standards.iteh.ai/catalog/standards/sist/9fcb89a6-85bf-4ea4-a01b-df10225f847a/iso-6149-1-2019>

*Partie 1: Orifices à joint torique dans un logement tronconique*



**iTeh STANDARD PREVIEW**  
**(standards.iteh.ai)**

ISO 6149-1:2019

<https://standards.iteh.ai/catalog/standards/sist/9fcb89a6-85bf-4ea4-a01b-dfd0ea5f84ac/iso-6149-1-2019>



**COPYRIGHT PROTECTED DOCUMENT**

© ISO 2019

All rights reserved. Unless otherwise specified, or required in the context of its implementation, no part of this publication may be reproduced or utilized otherwise in any form or by any means, electronic or mechanical, including photocopying, or posting on the internet or an intranet, without prior written permission. Permission can be requested from either ISO at the address below or ISO's member body in the country of the requester.

ISO copyright office  
CP 401 • Ch. de Blandonnet 8  
CH-1214 Vernier, Geneva  
Phone: +41 22 749 01 11  
Fax: +41 22 749 09 47  
Email: [copyright@iso.org](mailto:copyright@iso.org)  
Website: [www.iso.org](http://www.iso.org)

Published in Switzerland

# Contents

	Page
Foreword .....	iv
Introduction .....	v
<b>1 Scope .....</b>	<b>1</b>
<b>2 Normative references .....</b>	<b>1</b>
<b>3 Terms and definitions .....</b>	<b>1</b>
<b>4 Dimensions .....</b>	<b>2</b>
<b>5 Interchangeability warning .....</b>	<b>4</b>
<b>6 Test methods .....</b>	<b>4</b>
<b>7 Designation of ports .....</b>	<b>4</b>
<b>8 Identification .....</b>	<b>4</b>
<b>9 Identification statement (reference to this document) .....</b>	<b>5</b>
<b>Bibliography .....</b>	<b>6</b>

## iTeh STANDARD PREVIEW (standards.iteh.ai)

ISO 6149-1:2019

<https://standards.iteh.ai/catalog/standards/sist/9fcb89a6-85bf-4ea4-a01b-dfd0ea5f84ac/iso-6149-1-2019>

## Foreword

ISO (the International Organization for Standardization) is a worldwide federation of national standards bodies (ISO member bodies). The work of preparing International Standards is normally carried out through ISO technical committees. Each member body interested in a subject for which a technical committee has been established has the right to be represented on that committee. International organizations, governmental and non-governmental, in liaison with ISO, also take part in the work. ISO collaborates closely with the International Electrotechnical Commission (IEC) on all matters of electrotechnical standardization.

The procedures used to develop this document and those intended for its further maintenance are described in the ISO/IEC Directives, Part 1. In particular, the different approval criteria needed for the different types of ISO documents should be noted. This document was drafted in accordance with the editorial rules of the ISO/IEC Directives, Part 2 (see [www.iso.org/directives](http://www.iso.org/directives)).

Attention is drawn to the possibility that some of the elements of this document may be the subject of patent rights. ISO shall not be held responsible for identifying any or all such patent rights. Details of any patent rights identified during the development of the document will be in the Introduction and/or on the ISO list of patent declarations received (see [www.iso.org/patents](http://www.iso.org/patents)).

Any trade name used in this document is information given for the convenience of users and does not constitute an endorsement.

For an explanation of the voluntary nature of standards, the meaning of ISO specific terms and expressions related to conformity assessment, as well as information about ISO's adherence to the World Trade Organization (WTO) principles in the Technical Barriers to Trade (TBT) see [www.iso.org/iso/foreword.html](http://www.iso.org/iso/foreword.html).

This document was prepared by Technical Committee ISO/TC 131, *Fluid power systems*, Subcommittee SC 4, *Connectors and similar products and components*.

This third edition cancels and replaces the second edition (ISO 6149-1:2006), which has been technically revised.

The main change since the last version is the addition of a warning statement about the hazards of intermixing of stud ends with the various port types and a change to the port o-ring gland on sizes M8 and M10 to improve maximum volume fill.

A list of all the parts in the ISO 6149 series, can be found on the ISO website.

Any feedback or questions on this document should be directed to the user's national standards body. A complete listing of these bodies can be found at [www.iso.org/members.html](http://www.iso.org/members.html).

## Introduction

In hydraulic fluid power systems, power is transmitted and controlled through a liquid under pressure within an enclosed circuit. In general applications, a fluid (liquid or gas) may be conveyed under pressure.

Components are connected through their threaded ports by fluid conductor connectors to tubes and pipes or to hose connectors and hoses.

Ports are an integral part of fluid power components, i.e. pumps, motors, valves, cylinders.

For threaded ports and stud ends specified in new designs in hydraulic fluid power applications, ISO/TC 131/SC 4 recommends that the ISO 6149 series be used because these International Standards specify ports and stud ends with metric threads and O-ring sealing and because the subcommittee would like to help users by recommending one preferred system. ISO/TC 131/SC 4 further recommends that threaded ports and stud ends in accordance with the ISO 1179 series, the ISO 9974 series and the ISO 11926 series not be used for new designs in hydraulic fluid power applications; these International Standards are maintained because they specify ports and stud ends that are currently used in hydraulic systems worldwide

## iTeh STANDARD PREVIEW (standards.iteh.ai)

[ISO 6149-1:2019](https://standards.iteh.ai/catalog/standards/sist/9fcb89a6-85bf-4ea4-a01b-dfd0ea5f84ac/iso-6149-1-2019)

<https://standards.iteh.ai/catalog/standards/sist/9fcb89a6-85bf-4ea4-a01b-dfd0ea5f84ac/iso-6149-1-2019>

**iTeh STANDARD PREVIEW**  
**(standards.iteh.ai)**

ISO 6149-1:2019

<https://standards.iteh.ai/catalog/standards/sist/9fcb89a6-85bf-4ea4-a01b-dfd0ea5f84ac/iso-6149-1-2019>

# Connections for hydraulic fluid power and general use — Ports and stud ends with ISO 261 metric threads and O-ring sealing —

## Part 1: Ports with truncated housing for O-ring seal

### 1 Scope

This document specifies dimensions for metric ports for use with the adjustable and non-adjustable stud ends as described in ISO 6149-2 and ISO 6149-3.

Ports in accordance with this document can be used at working pressures up to 63 MPa [630 bar<sup>1)</sup>] for non-adjustable stud ends and 40 MPa (400 bar) for adjustable stud ends. The permissible working pressure depends upon port size, materials, design, working conditions, application, etc. See ISO 6149-2 and ISO 6149-3 for pressure ratings.

NOTE The Introduction of this document gives recommendations for ports and stud ends to be used for new designs in hydraulic fluid power applications.

### 2 Normative references

The following documents are referred to in the text in such a way that some or all of their content constitutes requirements of this document. For dated references, only the edition cited applies. For undated references, the latest edition of the referenced document (including any amendments) applies.

ISO 261, *ISO general purpose metric screw threads — General plan*

ISO 965-1, *ISO general purpose metric screw threads — Tolerances — Part 1: Principles and basic data*

ISO 2306, *Drills for use prior to tapping screw threads*

ISO 5598, *Fluid power systems and components — Vocabulary*

ISO 6149-2, *Connections for hydraulic fluid power and general use — Ports and stud ends with ISO 261 metric threads and O-ring sealing — Part 2: Dimensions, design, test methods and requirements for heavy-duty (S series) stud ends*

ISO 6149-3, *Connections for hydraulic fluid power and general use — Ports and stud ends with ISO 261 metric threads and O-ring sealing — Part 3: Dimensions, design, test methods and requirements for light-duty (L series) stud ends*

### 3 Terms and definitions

For the purposes of this document, the terms and definitions given in ISO 5598 apply.

ISO and IEC maintain terminological databases for use in standardization at the following addresses:

- IEC Electropedia: available at <http://www.electropedia.org/>
- ISO Online browsing platform: available at <https://www.iso.org/obp>

1) 1 bar = 0,1 MPa = 10<sup>5</sup> Pa; 1 MPa = 1 N/mm<sup>2</sup>.

### 4 Dimensions

Ports shall conform to the dimensions shown in [Figure 1](#) and given in [Table 1](#). Users of this document shall ensure that there is sufficient material around the port to maintain the pressure.

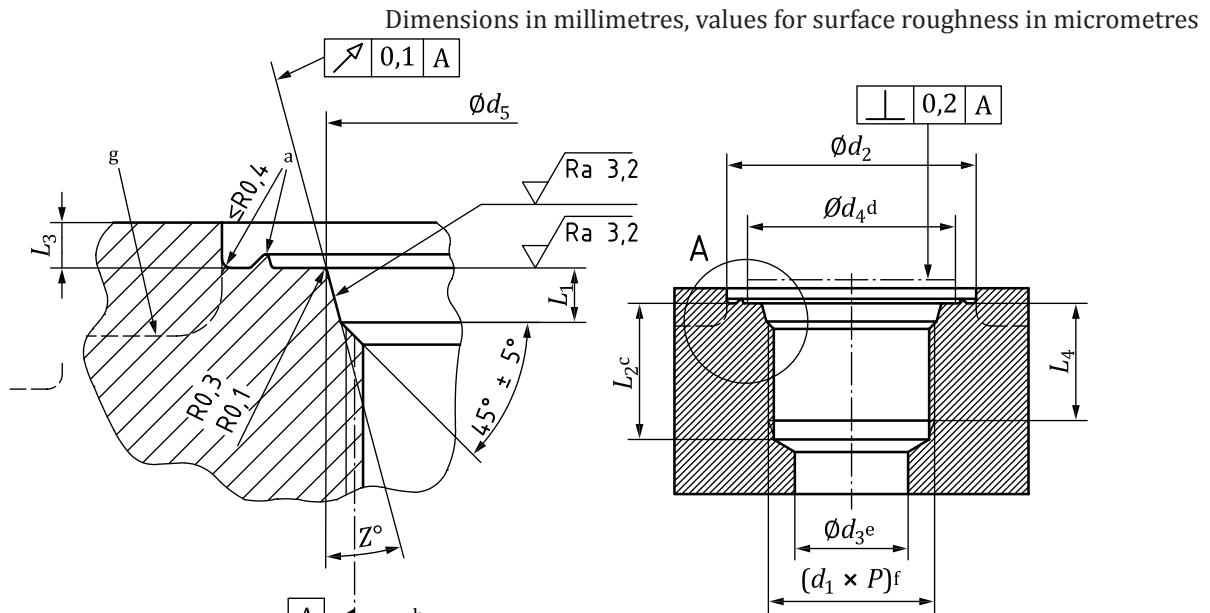

**Key**

- a Optional identification of port; see [Figure 2](#) and [Clause 7](#).
- b Pitch diameter.
- c This dimension only applies when tap drill cannot pass through entire boss.
- d Gauging.
- e Reference only.
- f Thread.
- g Counterbore diameter or minimum diameter for raised bosses.

**Figure 1 — Port**



Table 1 — Port dimensions

Dimensions in millimetres

Thread <sup>a</sup> ( $d_1 \times P$ )	$d_2$		$d_3^b$ ref.	$d_4$	$d_5$ +0,1 0	$L_1$ +0,4 0	$L_2^c$ min.	$L_3$ max.	$L_4$ min.	$Z^\circ$ $\pm 1^\circ$
	Wide <sup>d</sup> min.	Narrow <sup>e</sup> min.								
M8 × 1	17	14	3	12,5	9,1	2,2	11,5	1	10	12
M10 × 1	20	16	4,5	14,5	11,1	2,2	11,5	1	10	12
M12 × 1,5	23	19	6	17,5	13,8	2,4	14	1,5	11,5	15
M14 × 1,5 <sup>f</sup>	25	21	7,5	19,5	15,8	2,4	14	1,5	11,5	15
M16 × 1,5	28	24	9	22,5	17,8	2,4	15,5	1,5	13	15
M18 × 1,5	30	26	11	24,5	19,8	2,4	17	2	14,5	15
M20 × 1,5 <sup>g</sup>	33	29	—	27,5	21,8	2,4	—	2	14,5	15
M22 × 1,5	33	29	14	27,5	23,8	2,4	18	2	15,5	15
M27 × 2	40	34	18	32,5	29,4	3,1	22	2	19	15
M30 × 2	44	38	21	36,5	32,4	3,1	22	2	19	15
M33 × 2	49	43	23	41,5	35,4	3,1	22	2,5	19	15
M42 × 2	58	52	30	50,5	44,4	3,1	22,5	2,5	19,5	15
M48 × 2	63	57	36	55,5	50,4	3,1	25	2,5	22	15
M60 × 2	74	67	44	65,5	62,4	3,1	27,5	2,5	24,5	15

- a Conforming to ISO 261, tolerance grade 6H in accordance with ISO 965-1. Tap drills in accordance with ISO 2306, class 6H.
- b For reference only. Connecting hole application may require a different size.
- c The tap drill depths given require the use of a bottoming tap to produce the specified full thread lengths. Where standard taps are used, the tap drill depths shall be increased accordingly.
- d Spotface diameter with identification ridge.
- e Spotface diameter without identification ridge.
- f Preferred for diagnostic port applications.
- g For cartridge valve cavity applications only (see ISO 7789).

Dimensions in millimetres

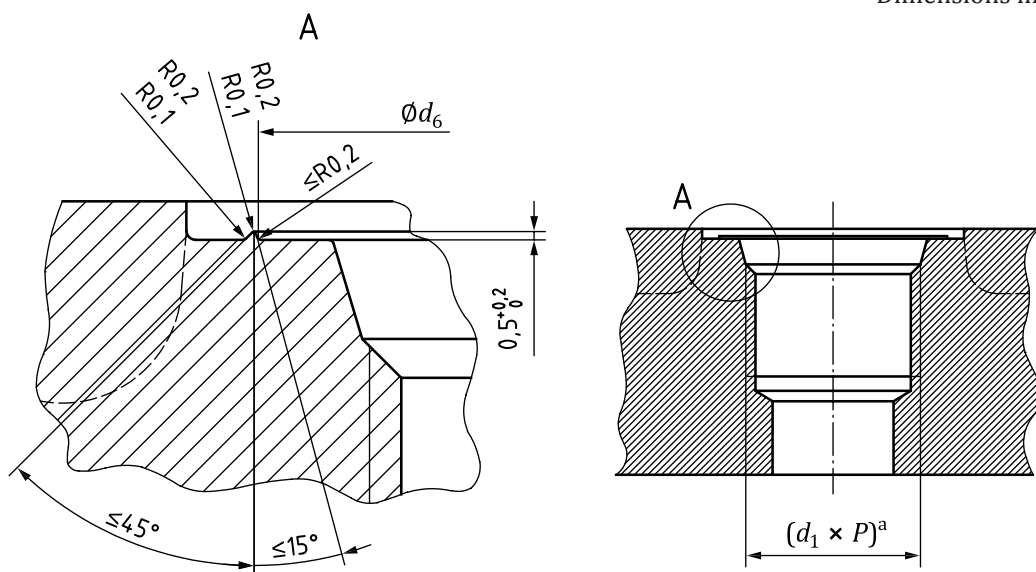

Key

- a Thread.

Figure 2 — Optional port identification