

---

---

**Rubber, vulcanized or  
thermoplastic — Determination of  
adhesion to a rigid substrate —  
90° peel method**

*Caoutchouc vulcanisé ou thermoplastique — Détermination de  
l'adhérence à un substrat rigide — Méthode par pelage à angle droit*

**iTeh STANDARD PREVIEW**  
**(standards.iteh.ai)**

ISO 813:2016

<https://standards.iteh.ai/catalog/standards/sist/5b5badb5-dcaa-4810-adbd-e8997708ff7c/iso-813-2016>



**iTeh STANDARD PREVIEW**  
**(standards.iteh.ai)**

ISO 813:2016

<https://standards.iteh.ai/catalog/standards/sist/5b5badb5-dcaa-4810-adbd-e8997708ff7c/iso-813-2016>



**COPYRIGHT PROTECTED DOCUMENT**

© ISO 2016, Published in Switzerland

All rights reserved. Unless otherwise specified, no part of this publication may be reproduced or utilized otherwise in any form or by any means, electronic or mechanical, including photocopying, or posting on the internet or an intranet, without prior written permission. Permission can be requested from either ISO at the address below or ISO's member body in the country of the requester.

ISO copyright office  
Ch. de Blandonnet 8 • CP 401  
CH-1214 Vernier, Geneva, Switzerland  
Tel. +41 22 749 01 11  
Fax +41 22 749 09 47  
copyright@iso.org  
www.iso.org

# Contents

Page

Foreword.....	iv
<b>1 Scope.....</b>	<b>1</b>
<b>2 Normative references.....</b>	<b>1</b>
<b>3 Principle.....</b>	<b>1</b>
<b>4 Apparatus.....</b>	<b>1</b>
<b>5 Test pieces.....</b>	<b>2</b>
5.1 Dimensions.....	2
5.2 Preparation.....	3
5.3 Number.....	4
5.4 Conditioning before testing.....	4
<b>6 Test temperature and humidity.....</b>	<b>4</b>
<b>7 Procedure.....</b>	<b>5</b>
<b>8 Expression of results.....</b>	<b>5</b>
8.1 Adhesion strength.....	5
8.2 Adhesion failure symbols.....	5
<b>9 Precision.....</b>	<b>5</b>
<b>10 Test report.....</b>	<b>6</b>
<b>Annex A (informative) Analysis of the viscoelastic behaviour of the bond.....</b>	<b>7</b>
<b>Annex B (normative) Calibration schedule.....</b>	<b>8</b>
<b>Bibliography.....</b>	<b>10</b>

ISO 813:2016

<https://standards.iteh.ai/catalog/standards/sist/5b5badb5-dcaa-4810-adbd-e8997708ff7c/iso-813-2016>

## Foreword

ISO (the International Organization for Standardization) is a worldwide federation of national standards bodies (ISO member bodies). The work of preparing International Standards is normally carried out through ISO technical committees. Each member body interested in a subject for which a technical committee has been established has the right to be represented on that committee. International organizations, governmental and non-governmental, in liaison with ISO, also take part in the work. ISO collaborates closely with the International Electrotechnical Commission (IEC) on all matters of electrotechnical standardization.

The procedures used to develop this document and those intended for its further maintenance are described in the ISO/IEC Directives, Part 1. In particular the different approval criteria needed for the different types of ISO documents should be noted. This document was drafted in accordance with the editorial rules of the ISO/IEC Directives, Part 2 (see [www.iso.org/directives](http://www.iso.org/directives)).

Attention is drawn to the possibility that some of the elements of this document may be the subject of patent rights. ISO shall not be held responsible for identifying any or all such patent rights. Details of any patent rights identified during the development of the document will be in the Introduction and/or on the ISO list of patent declarations received (see [www.iso.org/patents](http://www.iso.org/patents)).

Any trade name used in this document is information given for the convenience of users and does not constitute an endorsement.

For an explanation on the meaning of ISO specific terms and expressions related to conformity assessment, as well as information about ISO's adherence to the WTO principles in the Technical Barriers to Trade (TBT) see the following URL: [Foreword - Supplementary information](#)

The committee responsible for this document is ISO/TC 45, *Rubber and rubber products*, Subcommittee SC 2, *Testing and analysis*.

This fifth edition cancels and replaces the fourth edition (ISO 813:2010), of which it constitutes a minor revision concerning an update of the normative references.

# Rubber, vulcanized or thermoplastic — Determination of adhesion to a rigid substrate — 90° peel method

**WARNING 1** — Persons using this International Standard should be familiar with normal laboratory practice. This International Standard does not purport to address all of the safety problems, if any, associated with its use. It is the responsibility of the user to establish appropriate safety and health practices and to ensure compliance with any national regulatory conditions.

**WARNING 2** — Certain procedures specified in this International Standard may involve the use or generation of substances, or the generation of waste, that could constitute a local environmental hazard. Reference should be made to appropriate documentation on safe handling and disposal after use.

## 1 Scope

This International Standard specifies a method for the determination of the adhesive strength of a vulcanized or thermoplastic rubber bonded to a rigid substrate, using a test piece comprising a strip of rubber bonded to a single plate of rigid material. The test is carried out at a peel angle of 90°.

The method is applicable primarily to test pieces prepared in the laboratory under standard conditions, such as can be used to provide data for the choice of rubber compounds or adhesive systems, the development of such materials and the control of manufacturing processes.

This method is not suitable for high-hardness rubbers, typically above 85 IRHD.

## 2 Normative references

The following referenced documents are indispensable for the application of this document. For dated references, only the edition cited applies. For undated references, the latest edition of the referenced document (including any amendments) applies.

ISO 5893, *Rubber and plastics test equipment — Tensile, flexural and compression types (constant rate of traverse) — Specification*

ISO 18899:2013, *Rubber — Guide to the calibration of test equipment*

ISO 23529, *Rubber — General procedures for preparing and conditioning test pieces for physical test methods*

## 3 Principle

The force required to cause separation of a strip of rubber bonded to a rigid substrate is measured, the angle of separation being 90° and the width and thickness of the rubber and the rigid material being fixed within specified limits.

## 4 Apparatus

**4.1 Tensile-testing machine**, complying with the requirements of ISO 5893, capable of measuring force with an accuracy corresponding to class 1 and with a rate of traverse of the moving grip of 50 mm/min ± 5 mm/min.

**4.2 Fixture**, for holding the test piece to the moving grip of the testing machine (4.1) so that the direction of pull to cause separation is at all times during the test as nearly perpendicular as possible

to the plane of the bond between the rubber and the rigid substrate, i.e. making an angle of 90° with the face of the fixture. The fixture shown in [Figure 1](#) complies with this requirement.

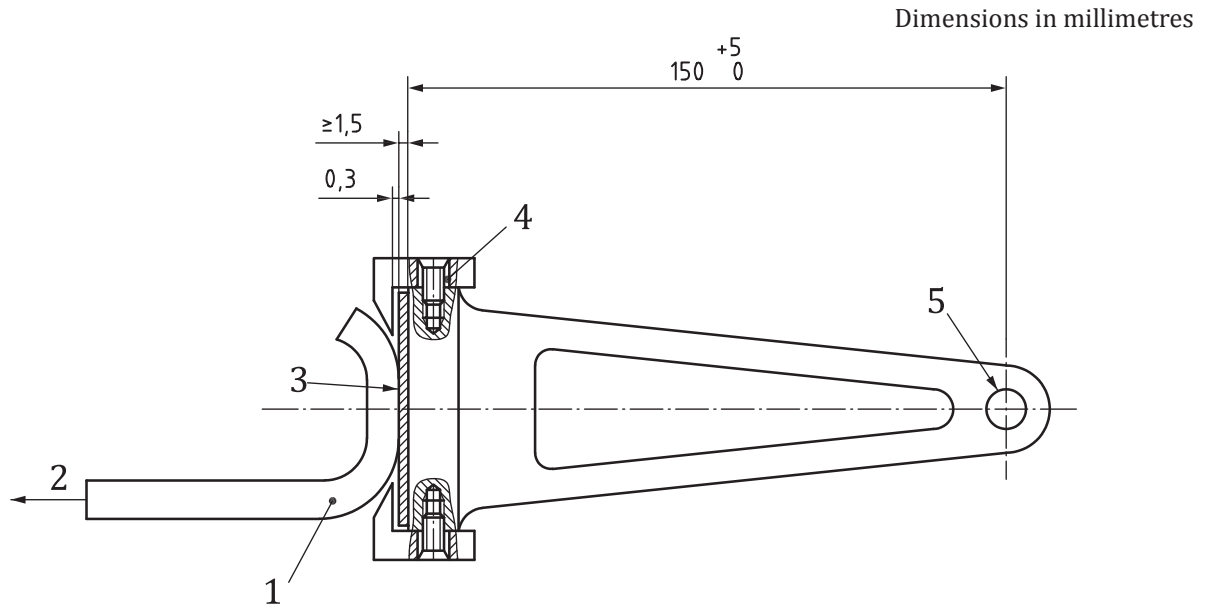

**Key**

- 1 rubber
- 2 tensile force
- 3 rigid substrate
- 4 adjustment grooves
- 5 attachment to upper grip of test machine

**iTeh STANDARD PREVIEW**  
(standards.iteh.ai)

ISO 813:2016  
<https://standards.iteh.ai/catalog/standards/sist/5b5badb5-dcaa-4810-adbd-e8997708f7c/iso-813-2016>

**Figure 1 — Example of test fixture**

**4.3 Grip**, so designed that it does not allow the rubber to slip or cause it to rupture.

**4.4 Temperature-controlled chamber** (if needed), for carrying out tests at a chosen temperature which can be kept within the tolerances given in ISO 23529.

**5 Test pieces**

**5.1 Dimensions**

The standard test piece shall consist of a strip of rubber 6 mm ± 0,1 mm thick in the test area, 25 mm ± 0,1 mm wide and 125 mm long, bonded to a square area, 25 mm long and 25 mm ± 0,1 mm wide on the surface of a strip of rigid substrate, the determination of the dimensions of the test piece being in accordance with ISO 23529.

The substrate shall be sufficiently thick to prevent deformation during the test: a minimum thickness of 1,5 mm is recommended. The width shall be 25 mm ± 0,1 mm and the length, 60 mm ± 1 mm.

Each test piece shall be prepared so that the bonded area, 25 mm long and 25 mm ± 0,1 mm wide, is approximately in the middle of the substrate as shown in [Figure 2](#).

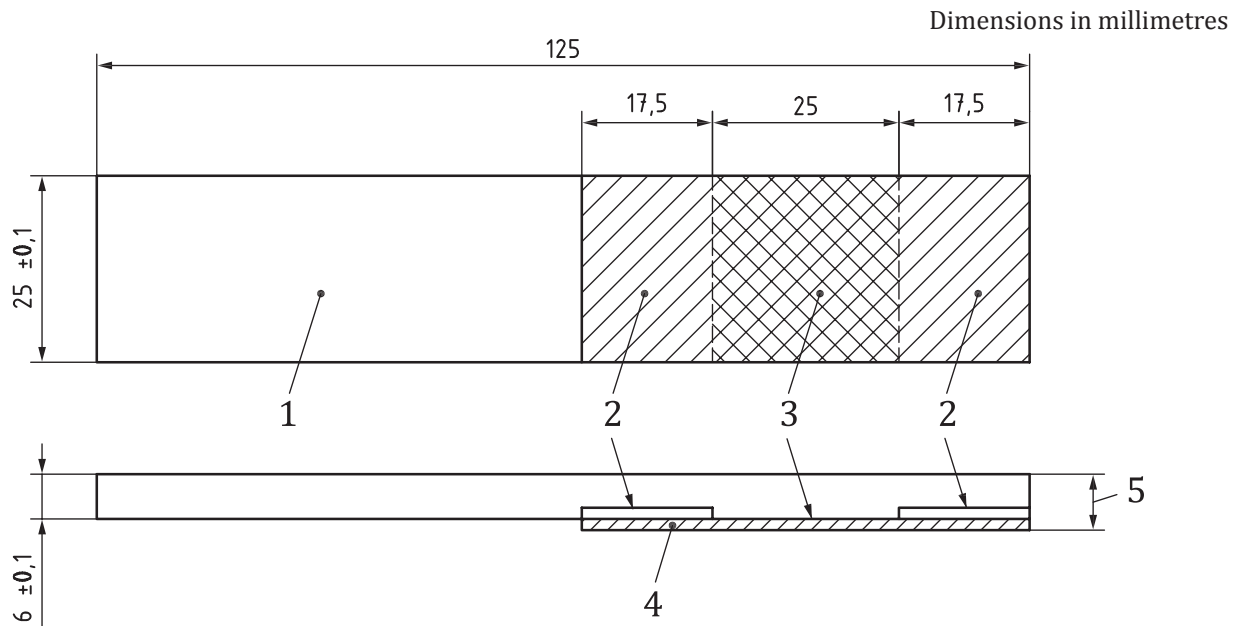

### Key

- 1 rubber
- 2 masked area
- 3 bonded area
- 4 rigid substrate
- 5 thickness depends on the thickness of the substrate

**iTeh STANDARD PREVIEW**  
(standards.iteh.ai)

ISO 813:2016  
**Figure 2 — Standard test piece**

<https://standards.iteh.ai/catalog/standards/sist/5b5badb5-dcaa-4810-adbd-e8997708ff7c/iso-813-2016>

## 5.2 Preparation

**5.2.1** Two types of mould can be used for the preparation of test pieces: moulds for several test pieces or moulds for single test pieces.

**5.2.1.1** When test pieces are to be made using one type of rubber and one type of adhesive system, a mould for several test pieces can be used. The inside mould dimension parallel to the longitudinal axis of the strip of substrate shall be 125 mm. The dimension corresponding to the transverse axis of the strip of substrate can be altered, depending on the number of test pieces to be prepared at a time. The dimension perpendicular to the longitudinal and transverse axes of the substrate can be altered, for instance using metal plates of various thicknesses, depending on the thickness of the substrate, in order to leave a depth of  $6 \text{ mm} \pm 0,05 \text{ mm}$  free for the rubber.

**5.2.1.2** When only one test piece is to be made from a given rubber, a mould as specified in [5.2.1.1](#) shall be used, except that the dimension corresponding to the transverse axis shall be restricted to the width of the test piece.

**5.2.2** From the rubber compound, cut slabs of sufficient thickness and of the required size for the mould (length 125 mm, width corresponding to the number of test pieces to be prepared) so as to ensure maximum pressure between the rubber and the substrate during the test piece preparation process.

**5.2.3** During test piece preparation, take great care to keep the surfaces to be bonded clean and free from dust, moisture and other foreign matter.

Prepare, in the way required by the adhesive system under investigation, the surface to be bonded of strips of substrate of the dimensions specified in 5.1. Mask both ends with pressure-sensitive tape so that only the area specified in 5.1 is available for bonding.

Clean the rubber surface to be bonded, using solvent or another technique as required by the adhesive system under investigation.

Apply the adhesive and assemble the strips of substrate and rubber. Place the assembly in the mould, with the substrate at the bottom. When more than one test piece is being prepared at a time, place the strips of substrate approximately 3 mm apart to permit subsequent separation of the test pieces.

**5.2.4** In the case of a rubber bonded with a heat-curing adhesive, carry out the vulcanization and/or bonding by heating the mould under pressure in a suitable press for the time and at the temperature required by the system being investigated.

Take great care when removing the test pieces from the mould to avoid subjecting the bonded surfaces to undue stress before the test pieces have cooled.

**NOTE** When the substrate used is a thermoplastic material, the strip may, in some cases, need to be raised to a temperature above its softening point in order to ensure adhesion. When the substrate is a thermosetting polymer, the starting material may, in some cases, be a low-viscosity prepolymer at the test piece preparation temperature, whose polymerization is completed during the process. The mould and the moulding pressure will have to be adapted to such cases.

**STANDARD PREVIEW**

**5.2.5** When more than one test piece is prepared at a time, separate the test pieces from each other for testing. Do this by cutting with scissors, a knife or another suitable tool. The edges of each test piece can then be buffed on a belt sander to bring the edge of the rubber flush with the edge of the substrate. Take care not to overheat the test piece and not to reduce the width of the test piece beyond the tolerance allowed.

**5.2.6** The test can also be used to measure post-vulcanization (PV) bonding, where preformed vulcanized rubber is bonded to the substrate. The conditions of bonding, such as temperature, pressure and surface preparation, shall be given in the test report.

### 5.3 Number

Four test pieces shall be tested.

### 5.4 Conditioning before testing

The time interval between the preparation of the test pieces and testing shall be in accordance with the requirements of ISO 23529. It shall be at least 16 h after moulding.

Condition the test pieces in accordance with the requirements of ISO 23529 for at least 16 h at a standard temperature ( $23\text{ °C} \pm 2\text{ °C}$  or  $27\text{ °C} \pm 2\text{ °C}$ ) immediately before the test.

When a test at other than standard laboratory temperature is required, carry out additional conditioning at this temperature for long enough to bring the material to the required temperature. ISO 23529 gives guidance on the conditioning time necessary to reach temperature equilibrium.

## 6 Test temperature and humidity

Unless otherwise specified, carry out testing at standard laboratory temperature, as specified in ISO 23529.



When other test temperatures are required, take them, as far as possible, from the list of preferred temperatures given in ISO 23529.

Use the same temperature throughout any one test, as well as any series of tests intended to be comparable.

## 7 Procedure

**7.1** Place the test piece symmetrically in the fixture (4.2), with the end to be pulled apart facing towards the operator. Before applying the load, strip the rubber from the substrate for a distance of about 2 mm, using a sharp knife and taking care not to introduce tears in the rubber. Place the free end of the rubber strip in the grip (4.3). In the case of tests at other than standard temperature, keep the test piece in the temperature-controlled chamber (4.4) for a sufficient length of time after closure of the chamber for the test piece to reach the required temperature. Then move the grip of the tensile-testing machine at 50 mm/min  $\pm$  5 mm/min until separation is complete. Record the maximum force required to cause separation.

Other speeds of separation may be used to examine the viscoelastic behaviour of the bond (see Annex A). In such cases, the use of logarithmic increments in the speed of separation is recommended.

**7.2** An autographic recording of the force of adhesion over the full length of the test piece can also be made.

**7.3** During the test, cut the rubber back to the substrate with the knife whenever the rubber tends to tear.

## 8 Expression of results

### 8.1 Adhesion strength

Calculate the adhesion strength, in newtons per millimetre, by dividing the maximum force, in newtons, recorded in 7.1 by the width, in millimetres, of the test piece.

### 8.2 Adhesion failure symbols

Assess the type of failure, using the following symbols:

- R When the failure is in the rubber.
- RC When the failure is at the interface between the rubber and the layer of adhesive.
- CP When the failure is at the interface between the layer of adhesive and the primer (if used).
- PS When the failure is at the interface between the primer (if used) and the substrate.
- CS When the failure is at the interface between the adhesive and the substrate (when no primer is used).
- D When the failure is at the interface between the rubber and the substrate in the case of direct adhesion, i.e. no adhesive used.
- S When the failure is in the substrate.

## 9 Precision

No precision data are currently available for this method.