



**SLOVENSKI STANDARD**  
**SIST EN 300 417-6-1 V1.1.2:2003**  
**01-december-2003**

---

DfYbcg`j]b`a i `hjd`Y\_gj]fUb`Y`fHAŁĚ; YbYf] bY`nU hYj Y`nUdfYbcgbc`Z b\_W]cbUbcgh  
cdfYa YĚ\*!%`XY.`: i b\_W]Y`g]b\ fcb]nUW]g\_Y`d`Ugh

Transmission and Multiplexing (TM); Generic requirements of transport functionality of equipment; Part 6-1: Synchronization layer functions

**iteh STANDARD PREVIEW**  
**(standards.iteh.ai)**

Ta slovenski standard je istoveten z: **EN 300 417-6-1 Version 1.1.2**  
<https://standards.iteh.ai/catalog/standards/sist/30ad4fa1-6ab1-45ab-ab4a-acf09f8505ee/sist-en-300-417-6-1-v1-1-2-2003>

---

**ICS:**

33.040.20      Prenosni sistem      Transmission systems

**SIST EN 300 417-6-1 V1.1.2:2003**      en

**iTeh STANDARD PREVIEW**  
**(standards.iteh.ai)**

SIST EN 300 417-6-1 V1.1.2:2003

<https://standards.iteh.ai/catalog/standards/sist/30ad4fa1-6abf-43ab-ab4a-acf09f8505ee/sist-en-300-417-6-1-v1-1-2-2003>

# EN 300 417-6-1 V1.1.2 (1998-11)

---

*European Standard (Telecommunications series)*

## **Transmission and Multiplexing (TM); Generic requirements of transport functionality of equipment; Part 6-1: Synchronization layer functions**

---

**iTeh STANDARD PREVIEW**  
**(standards.iteh.ai)**

[SIST EN 300 417-6-1 V1.1.2:2003](https://standards.iteh.ai/catalog/standards/sist/30ad4fa1-6abf-43ab-ab4a-acf09f8505ee/sist-en-300-417-6-1-v1-1-2-2003)

<https://standards.iteh.ai/catalog/standards/sist/30ad4fa1-6abf-43ab-ab4a-acf09f8505ee/sist-en-300-417-6-1-v1-1-2-2003>



---

**Reference**

REN/TM-01015-6-1 (3v1i9idc.PDF)

---

**Keywords**

SDH, transmission, synchronization

**ETSI****Postal address**

F-06921 Sophia Antipolis Cedex - FRANCE

**Office address**

650 Route des Lucioles - Sophia Antipolis  
Valbonne - FRANCE

Tel.: +33 4 92 94 42 00 - Fax: +33 4 93 65 47 16

Siret N° 348 623 562 00017 - NAF 742 C

Association à but non lucratif enregistrée à la  
Sous-Préfecture de Grasse (06) N° 7803/88

**Internet**

secretariat@etsi.fr

<http://www.etsi.org>

---

**Copyright Notification**

No part may be reproduced except as authorized by written permission.  
The copyright and the foregoing restriction extend to reproduction in all media.

© European Telecommunications Standards Institute 1998.  
All rights reserved.

# Contents

Intellectual Property Rights.....	6
Foreword .....	6
1 Scope.....	8
2 References.....	8
3 Definitions, abbreviations and symbols.....	9
3.1 Definitions .....	9
3.2 Abbreviations.....	10
3.3 Symbols and diagrammatic conventions.....	11
3.4 Introduction.....	11
4 Synchronization principles.....	11
4.1 Network synchronization .....	11
4.2 Synchronization distribution trails .....	13
4.3 Synchronization interfaces.....	13
4.3.1 Synchronous Transport Module, level N (STM-N).....	14
4.3.2 2 Mbit/s .....	14
4.3.3 2 MHz .....	14
4.3.4 34 Mbit/s and 140 Mbit/s with 125 $\mu$ s frame structure.....	14
4.4 Clock-Source Quality-Level .....	14
4.4.1 Clock-Source Quality- Level Definitions .....	14
4.4.2 Hierarchy of Clock-Source Quality Level or (CS_QL).....	15
4.4.3 Forcing of Clock-Source Quality-Levels.....	15
4.5 SSM and TM channels.....	15
4.5.1 SSM and TM message sets.....	16
4.5.2 SSM and TM code word generation.....	16
4.5.3 SSM and TM code word interpretation.....	17
4.6 Selection process .....	18
4.7 Signal fail.....	18
4.8 Hold-off time .....	19
4.9 WTR time .....	19
4.10 Synchronization source priorities.....	19
4.11 External commands (EXTCMD) .....	20
4.11.1 EXTCMDs per nominated synchronization source.....	20
4.11.1.1 Set_Lockout#p command.....	20
4.11.1.2 Clear_Lockout#p command.....	20
4.11.2 EXTCMDs per selection process .....	20
4.11.2.1 CLR command.....	20
4.11.2.2 Forced switch #p command .....	21
4.11.2.3 Manual switch #p command .....	21
4.12 Automatic reference selection process.....	21
4.12.1 QL-enabled mode.....	21
4.12.2 QL-disabled mode .....	22
4.13 Timing loop prevention.....	22
4.13.1 Station clock input used as a source for station clock output .....	22
4.13.2 Between NEs with SEC type clocks.....	22
4.13.3 Between NEs with a SEC clock and a NE or SASE with a SSU clock and only one link.....	23
4.13.3.1 QL/SSM processing supported between SASE and NE .....	23
4.13.3.2 QL/SSM processing not supported between SASE and NE .....	25
4.13.4 Between NEs with a SEC clock and a NE or SASE with a SSU clock and several links.....	27
4.14 Delay times for NEs with SEC.....	27
4.15 Delay times for NEs with SSU or for SASE .....	28
4.16 Synchronization layer functions.....	28
4.17 Overview of the processes performed within the atomic functions.....	30

5	Synchronization distribution layer atomic functions .....	31
5.1	SD Connection function (SD_C) .....	32
5.2	SD Trail Termination (TT) functions.....	33
5.2.1	SD TT source function (SD_TT_So) .....	33
5.2.2	SD TT sink function (SD_TT_Sk) .....	34
5.3	SD adaptation functions .....	36
5.3.1	SD layer to NS layer SEC quality adaptation source function (SD/NS-SEC-A_So).....	36
5.3.2	SD layer to NS layer SEC quality adaptation sink function (SD/NS-SEC_A_Sk).....	40
5.3.3	SD layer to NS layer SSU quality adaptation source function (SD/NS-SSU-A_So).....	41
5.3.4	SD layer to NS layer SSU quality adaptation sink function (SD/NS-SSU_A_Sk).....	41
5.3.5	SD layer to NS layer PRC quality adaptation source function (SD/NS-PRC-A_So) .....	41
5.3.6	SD layer to NS layer adaptation source function (SD/NS_A_So).....	41
6	NS layer atomic functions.....	43
6.1	NS_connection functions (NS_C).....	43
7	TL to SD layer atomic function .....	46
7.1	STM-1 multiplex section adaptation functions .....	46
7.1.1	STM-1 multiplex section to sd adaptation source (MS1/SD_A_So).....	46
7.1.2	STM-1 multiplex section to SD adaptation sink (MS1/SD_A_Sk) .....	48
7.2	STM-4 multiplex section adaptation functions .....	49
7.2.1	STM-4 multiplex section to SD adaptation source (MS4/SD_A_So) .....	49
7.2.2	STM-4 multiplex section to SD adaptation sink (MS4/SD_A_Sk) .....	51
7.3	STM-16 multiplex section adaptation functions .....	53
7.3.1	STM-16 multiplex section to SD adaptation source (MS16/SD_A_So) .....	53
7.3.2	STM-16 multiplex section to SD adaptation sink (MS16/SD_A_Sk) .....	55
7.4	P31s adaptation functions .....	56
7.4.1	P31s to SD adaptation source (P31s/SD_A_So) .....	56
7.4.2	P31s to SD adaptation sink (P31s/SD_A_Sk) .....	58
7.5	P4s adaptation functions .....	60
7.5.1	P4s to SD adaptation source (P4s/SD_A_So) .....	60
7.5.2	P4s to SD adaptation sink (P4s/SD_A_Sk) .....	63
7.6	P12s layer adaptation functions .....	65
7.6.1	P12s layer adaptation source functions .....	65
7.6.1.1	Type 1 P12s to SD adaptation source for station clock output supporting SSM (P12s/SD-sc-1_A_So).....	65
7.6.1.2	Type 2 P12s to SD adaptation source for station clock output port not supporting SSM (P12s/SD-sc-2_A_So).....	68
7.6.2	P12s layer adaptation sink functions .....	70
7.6.2.1	Type 1 P12s to SD adaptation sink for traffic input port (P12s/SD-tf_A_Sk).....	70
7.6.2.2	Type 2 P12s to SD adaptation sink for station clock input port (P12s/SD-sc_A_Sk) .....	72
7.7	T12 layer adaptation functions.....	74
7.7.1	T12 to SD adaptation source (T12/SD_A_So).....	74
7.7.2	T12 to SD adaptation sink (T12/SD_A_Sk).....	76
8	Equipment clock to TLs clock adaptation functions.....	78
8.1	STM-N layer.....	78
8.1.1	STM-1 Layer Clock (LC) adaptation source (MS1-LC_A_So) .....	78
8.1.2	STM-4 LC adaptation source (MS4-LC_A_So) .....	79
8.1.3	STM-16 LC adaptation source (MS16-LC_A_So) .....	80
8.2	VC layers .....	81
8.2.1	VC-4 LC adaptation source (S4-LC_A_So).....	81
8.2.2	VC-3 LC adaptation source (S3-LC_A_So).....	82
8.2.3	VC-2 LC adaptation source (S2-LC_A_So).....	83
8.2.4	VC-12 LC adaptation source (S12-LC_A_So).....	84
8.2.5	VC-11 LC adaptation source (S11-LC_A_So).....	85
8.3	Pxx layers.....	86
8.3.1	P4s LC adaptation source (P4s-LC_A_So) .....	86
8.3.2	P31s LC adaptation source (P31s-LC_A_So) .....	87
8.3.3	P12s LC adaptation source (P12s-LC_A_So) .....	88
8.4	T12 layer.....	89

8.4.1	T12 LC adaptation source (T12-LC_A_So).....	89
<b>Annex A (normative):</b>	<b>Synchronization selection process.....</b>	<b>90</b>
<b>Annex B (informative):</b>	<b>TL models for synchronization information.....</b>	<b>101</b>
<b>Annex C (informative):</b>	<b>Examples of synchronization functionality in the NE.....</b>	<b>104</b>
<b>Annex D (informative):</b>	<b>Delay time allocation .....</b>	<b>107</b>
D.1	Delay and processing times for the synchronization selection process .....	107
D.2	Non switching message delay $T_{NSM}$ .....	108
D.3	Switching message delay $T_{SM}$ .....	108
D.4	Holdover message delay $T_{HM}$ .....	109
D.5	Wait to restore time $T_{WTR}$ .....	110
<b>Annex E (informative):</b>	<b>Overview of inputs/outputs to the atomic functions .....</b>	<b>111</b>
	Bibliography .....	112
	History .....	113

## iTeh STANDARD PREVIEW (standards.iteh.ai)

[SIST EN 300 417-6-1 V1.1.2:2003](https://standards.iteh.ai/catalog/standards/sist/30ad4fa1-6abf-43ab-ab4a-acf09f8505ee/sist-en-300-417-6-1-v1-1-2-2003)

<https://standards.iteh.ai/catalog/standards/sist/30ad4fa1-6abf-43ab-ab4a-acf09f8505ee/sist-en-300-417-6-1-v1-1-2-2003>

---

## Intellectual Property Rights

IPRs essential or potentially essential to the present document may have been declared to ETSI. The information pertaining to these essential IPRs, if any, is publicly available for **ETSI members and non-members**, and can be found in SR 000 314: "*Intellectual Property Rights (IPRs); Essential, or potentially Essential, IPRs notified to ETSI in respect of ETSI standards*", which is available **free of charge** from the ETSI Secretariat. Latest updates are available on the ETSI Web server (<http://www.etsi.org/ipr>).

Pursuant to the ETSI IPR Policy, no investigation, including IPR searches, has been carried out by ETSI. No guarantee can be given as to the existence of other IPRs not referenced in SR 000 314 (or the updates on the ETSI Web server) which are, or may be, or may become, essential to the present document.

---

## Foreword

This European Standard (Telecommunications series) has been produced by ETSI Technical Committee Transmission and Multiplexing (TM).

The present document is one of a family of documents that has been produced in order to provide inter-vendor and inter-operator compatibility of Synchronous Digital Hierarchy (SDH) equipment.

The present document is part 6-1 of a multi-part EN covering the Generic requirements of transport functionality of equipment, as identified below:

Part 1-1: "Generic processes and performance".

Part 1-2: "General information about Implementation Conformance Statement (ICS) proforma".

Part 1-3 "Generic processes and performance; Abstract Test Suite (ATS)".

Part 2-1: "Synchronous Digital Hierarchy (SDH) and Plesiochronous Digital Hierarchy (PDH) physical section layer functions".

Part 2-2: "Synchronous Digital Hierarchy (SDH) and Plesiochronous Digital Hierarchy (PDH) physical section layer functions; Implementation Conformance Statement (ICS) proforma specification".

Part 2-3: "Synchronous Digital Hierarchy (SDH) and Plesiochronous Digital Hierarchy (PDH) physical section layer functions; Abstract Test Suite (ATS)".

Part 3-1: "Synchronous Transport Module-N (STM-N) regenerator and multiplex section layer functions".

Part 3-2: "Synchronous Transport Module-N (STM-N) regenerator and multiplex section layer functions; Implementation Conformance Statement (ICS) proforma specification".

Part 3-3: "Synchronous Transport Module-N (STM-N) regenerator and multiplex section layer functions; Abstract Test Suite (ATS)".

Part 4-1: "Synchronous Digital Hierarchy (SDH) path layer functions".

Part 4-2: "Synchronous Digital Hierarchy (SDH) path layer functions; Implementation Conformance Statement (ICS) proforma specification".

Part 4-3: "Synchronous Digital Hierarchy (SDH) path layer functions; Abstract Test Suite (ATS)".

Part 5-1: "Plesiochronous Digital Hierarchy (PDH) path layer functions".

Part 5-2: "Plesiochronous Digital Hierarchy (PDH) path layer functions; Implementation Conformance Statement (ICS) proforma specification".

Part 5-3: "Plesiochronous Digital Hierarchy (PDH) path layer functions; Abstract Test Suite (ATS)".

**Part 6-1: "Synchronization layer functions".**



Part 6-2: "Synchronization layer functions; Implementation Conformance Statement (ICS) proforma specification".

Part 6-3: "Synchronization layer functions; Abstract Test Suite (ATS)".

Part 7-1: "Auxiliary layer functions".

Part 7-2: "Auxiliary layer functions; Implementation Conformance Statement (ICS) proforma specification".

Part 7-3: "Auxiliary layer functions; Abstract Test Suite (ATS)".

Parts 2 to 7 specify the layers and their atomic functions.

NOTE 1: The present document does not currently address configuration management.

NOTE 2: The SDH radio equipment functional blocks are addressed by ETSI WG TM4.

Various of the above parts have previously been published as parts of ETS 300 417.

They have been converted to parts of EN 300 417 without technical changes, but some editorial changes have been necessary (e.g. references). In particular:

- Parts 2-1 and 3-2 have been modified to take account of editorial errors present in edition 1.
- Part 1-1 has had its title change of to align with other parts published at a later date.

Also note that in the meantime parts 8-1, 8-2 and 8-3 have been stopped.

<b>Transposition dates</b>	
Date of adoption of this EN:	24 July 1998
Date of latest announcement of this EN (doa):	30 November 1998
Date of latest publication of new National Standard or endorsement of this EN (dop/e):	31 May 1999
Date of withdrawal of any conflicting National Standard (dow):	31 May 1999

## 1 Scope

The present document specifies a library of basic Synchronization Distribution (SD) building blocks, referred to as "atomic functions" and a set of rules by which they are combined in order to describe a digital transmission equipment. The library defined in the present document forms part of the set of libraries defined in EN 300 417 series. The library comprises the functional building blocks needed to completely specify the generic functional structure of the European digital transmission hierarchy. Equipment that is compliant with the present document should be describable as an interconnection of a subset of these functional blocks contained within the present document. The interconnection of these blocks should obey the combination rules given in EN 300 417. The generic functionality is described in EN 300 417-1-1 [6].

The present document assumes that there are only two types of Synchronization Supply Units (SSUs), transit and local, as currently defined in CCITT Recommendation G.812 [17]. However, STC TM3 has approved in September 1996 a new SSU with enhanced characteristics. The inclusion of such an SSU in the present document is for further study.

The present document does not specify the atomic functions that are specific to SSU and Primary Reference Clock (PRC); the Synchronization Status Message (SSM) selection algorithm specified in the present document applies only to SEC's.

## 2 References

The following documents contain provisions which, through reference in this text, constitute provisions of the present document.

- References are either specific (identified by date of publication, edition number, version number, etc.) or non-specific.
- For a specific reference, subsequent revisions do not apply.
- For a non-specific reference, the latest version applies.
- A non-specific reference to an ETS shall also be taken to refer to later versions published as an EN with the same number.

- [1] ETS 300 147: "Transmission and Multiplexing (TM); Synchronous Digital Hierarchy (SDH); Multiplexing structure".
- [2] ETS 300 166 (1993): "Transmission and Multiplexing (TM); Physical and electrical characteristics of hierarchical digital interfaces for equipment using the 2 048 kbit/s - based plesiochronous or synchronous digital hierarchies".
- [3] ETS 300 167: "Transmission and Multiplexing (TM); Functional characteristics of 2 048 kbit/s interfaces".
- [4] ETS 300 337 (1996): "Transmission and Multiplexing (TM); Generic frame structures for the transport of various signals (including Asynchronous Transfer Mode (ATM) cells and Synchronous Digital Hierarchy (SDH) elements) at the ITU-T Recommendation G.702 hierarchical rates of 2 048 kbit/s, 34 368 kbit/s and 139 264 kbit/s".
- [5] ETS 300 337 (1995): "Transmission and Multiplexing (TM); Generic frame structures for the transport of various signals (including Asynchronous Transfer Mode (ATM) cells and Synchronous Digital Hierarchy (SDH) elements) at the ITU-T Recommendation G.702 hierarchical rates of 2 048 kbit/s, 34 368 kbit/s and 139 264 kbit/s".
- [6] EN 300 417-1-1: "Transmission and Multiplexing (TM); Generic requirements of transport functionality of equipment; Part 1-1: Generic processes and performance".
- [7] EN 300 417-2-1: "Transmission and Multiplexing (TM); Generic requirements of transport functionality of equipment; Part 2-1: Synchronous Digital Hierarchy (SDH) and Plesiochronous Digital Hierarchy (PDH) physical section layer functions".

- [8] EN 300 462-1-1: "Transmission and Multiplexing (TM); Generic requirements for synchronization networks; Part 1-1: Definitions and terminology for synchronization networks".
- [9] EN 300 462-2-1: "Transmission and Multiplexing (TM); Generic requirements for synchronization networks; Part 2-1: Synchronization network architecture".
- [10] EN 300 462-4-1: "Transmission and Multiplexing (TM); Generic requirements for synchronization networks; Part 4-1: Timing characteristics of slave clocks suitable for synchronization supply to Synchronous Digital Hierarchy (SDH) and Plesiochronous Digital Hierarchy (PDH) equipment".
- [11] EN 300 462-5-1: "Transmission and Multiplexing (TM); Generic requirements for synchronization networks; Part 5-1: Timing characteristics of slave clocks suitable for operation in Synchronous Digital Hierarchy (SDH) equipment".
- [12] EN 300 462-6-1: "Transmission and Multiplexing (TM); Generic requirements for synchronization networks; Part 6-1: Timing characteristics of primary reference clocks".
- [13] ITU-T Recommendation G.704 (1995): "Synchronous frame structures used at 1 544, 6 312, 2 048, 8 488 and 44 736 kbit/s hierarchical levels".
- [14] ITU-T Recommendation G.707 (1996): "Network node interface for the synchronous digital hierarchy (SDH)".
- [15] ITU-T Recommendation G.783: "Characteristics of synchronous digital hierarchy (SDH) equipment functional blocks".
- [16] CCITT Recommendation G.811 (1988): "Timing requirements at the outputs of primary reference clocks suitable for plesiochronous operation of international digital links".
- [17] CCITT Recommendation G.812 (1988.): "Timing requirements at the outputs of slave clocks suitable for plesiochronous operation of international digital links".
- [18] ITU-T Recommendation G.813 (1996): "Timing characteristics of SDH equipment slave clocks (SEC)".

STANDARD PREVIEW  
(standards.iteh.ai)  
SIST EN 300 417-6-1 V1.1.2:2003  
<https://standards.iteh.ai/catalog/standards/sist/30ad4fa1-6abf-43ab-ab4a-acf09f8505ee/sist-en-300-417-6-1-v1-1-2-2003>

## 3 Definitions, abbreviations and symbols

### 3.1 Definitions

For the purposes of the present document, the following definition applies:

**Timing loop:** This is a network condition where a slave clock providing synchronization becomes locked to its own timing signal. It is generally created when the slave clock Timing Information (TI) is looped back to its own input, either directly or via other network equipments. Timing loops should be prevented in networks by careful network design.

**QL minimum:** QL\_minimum is a configurable parameter used in the squelching of clock output signals. If the Quality Level (QL) of the signal used to derive the output falls below QL\_Minimum then the output will be squelched (cut-off or set to Alarm Indication Signal (AIS)).

**Clock-Source Quality-Level:** The clock-source quality-level of a SDH Equipment Clock (SEC) or Stand Alone Synchronization Equipment (SASE) is defined as the grade of clock to which it is ultimately traceable; i.e. the grade-of-clock to which it is synchronized directly or indirectly via a chain of SEC's, and SASE's however long this chain of clocks is. For example, the clock-source quality-level may be a PRC complying with EN 300 462-6-1 [12], or it may be a Slave Clock in holdover-mode, complying with EN 300 462-4-1 [10], or a EN 300 462-5-1 [11] Clock in holdover or free-run.

The clock-source quality-level is essentially, therefore, an indication only of the long-term accuracy of the Network Element (NE) Clock.

**Station Clock:** This is a node clock as defined in EN 300 462-1-1 [8].

The functional definitions are given in EN 300 417-1-1 [6].

## 3.2 Abbreviations

For the purposes of the present document, the following abbreviations apply:

AI	Adaptation Information
AIS	Alarm Indication Signal
AP	Access Point
CI	Characteristic Information
CK	timing information - Clock signal
CLR	Clear
CP	Connection Point
CS	timing information - Clock Source
CSid	Clock Source identifier
DNU	Do Not Use
ES1	STM-1 Electrical Section layer
EXTCMD	External Command
FS	timing information - Frame Start
FSw	Forced Switch
HO	Hold Over mode
HO	Hold Off time
ID	IDentifier
INVx	INValid x
LC	Layer Clock
LO	Lock Out
LO	Locked mode
LOS	Loss Of Signal
LSB	Least Significant Bit
LTI	Loss of Timing Information
MA	Maintenance and Adaptation
MI	Management Information
MON	MONitored
MFP	MultiFrame Present
MFS	MultiFrame Start
MS	Multiplex Section
MSB	Most Significant Bit
MSw	Manual Switch
MTIE	Maximum Time Interval Error
NE	Network Element
NS	Network Synchronization
NSUPP	Not supported
OSn	STM-N Optical Section layer
P12s	2 048 kbit/s PDH path layer with synchronous 125 $\mu$ s frame structure according to ETS 300 167 [3]
P31s	34 368 kbit/s PDH path layer with synchronous 125 $\mu$ s frame structure according to ETS 300 337 [4]
P4s	139 264 kbit/s PDH path layer with synchronous 125 $\mu$ s frame structure according to ETS 300 337 [4]
PDH	Plesiochronous Digital Hierarchy
PRC	Primary Reference Clock
QL	Quality Level
RI	Remote Information
RSn	STM-N Regenerator Section layer
SASE	Stand Alone Synchronization Equipment
SD	Synchronization Distribution
SDH	Synchronous Digital Hierarchy
SDL	Specification and Description Language
SEC	SDH Equipment Clock

ITEH STANDARD PREVIEW

(standards.iteh.ai)

SIST EN 300 417-6-1 V1.1.2:2003

<https://standards.iteh.ai/catalog/standards/sist/30ad4fa1-6abf-43ab-ab4a-act09f8505ee/sist-en-300-417-6-1-v1-1-2-2003>

act09f8505ee/sist-en-300-417-6-1-v1-1-2-2003

SF	Signal Fail
SQLCH	Squelch
SSF	Server Signal Fail
SSM	Synchronization Status Message
SSU	Synchronization Supply Unit
SSUL	Local SSU
SSUT	Transit SSU
STM-N	Synchronous Transport Module, level N
Sk	Sink
So	Source
TCP	Termination Connection Point
TDEV	Time DEVIation
TI	Timing Information
TL	Transport Layer
TM	Timing Marker
TT	Trail Termination
TSF	Trail Signal Fail
UNC	UNConnected
VC-n	Virtual Container, level n
WTR	Wait to Restore

### 3.3 Symbols and diagrammatic conventions

For the purposes of the present document, the symbols and diagrammatic conventions given in EN 300 417-1-1 [6] apply.

iTeh STANDARD PREVIEW

### 3.4 Introduction (standards.iteh.ai)

This subclause defines the atomic functions that are part of the 2 synchronization layers, the SD layer and the Network Synchronization (NS) layer. It also defines some atomic functions, part of the Transport Layer (TL), which are related with synchronization.

These functions describe the synchronization of SDH NEs and how SDH NEs are involved in NS.

---

## 4 Synchronization principles

### 4.1 Network synchronization

Synchronization network architecture is specified in EN 300 462-2-1 [9].

Synchronization information is transmitted through the network via synchronization network connections. These synchronization network connections can transport different synchronization levels. Each synchronization network connection is provided by one or more synchronization link connections, each supported by a synchronized primary or secondary rate Plesiochronous Digital Hierarchy (PDH) trail or SDH multiplex section trail (see clause 5 of EN 300 462-2-1 [9]).

Some of these synchronized primary or secondary rate PDH trail or SDH multiplex section trail signals contain a communication channel, the SSM or the Timing Marker (TM) transporting a quality Identifier (ID). This QL ID can be used to select the highest synchronization level incoming reference signal from a set of nominated synchronization references available at the NE.

Synchronization network connections are uni-directional and generally point to multipoint. EN 300 462-2-1 [9] specifies a master-slave synchronization technique for synchronizing SDH networks (see subclause 4.1 of EN 300 462-2-1 [9]). Figures 1 to 4 illustrate the synchronization network connection model.

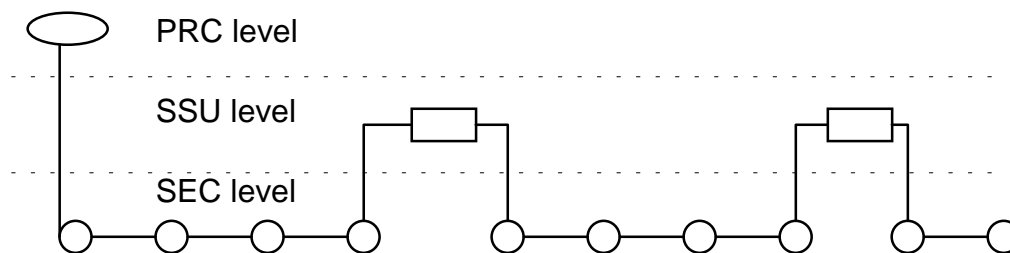

Figure 1: General representation of a synchronization network

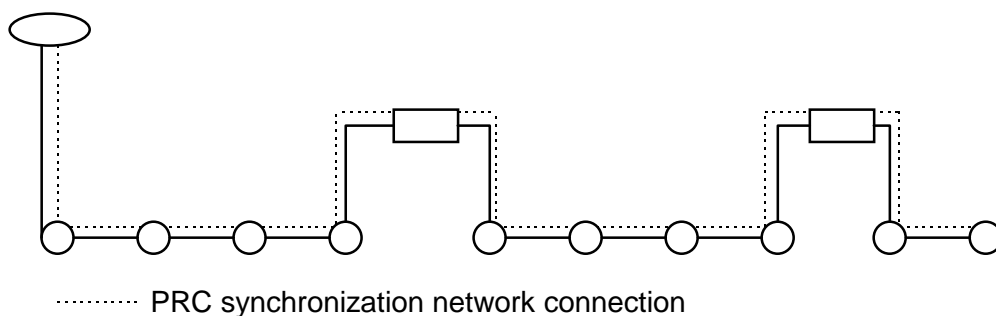

Figure 2: Representation of the PRC network connection

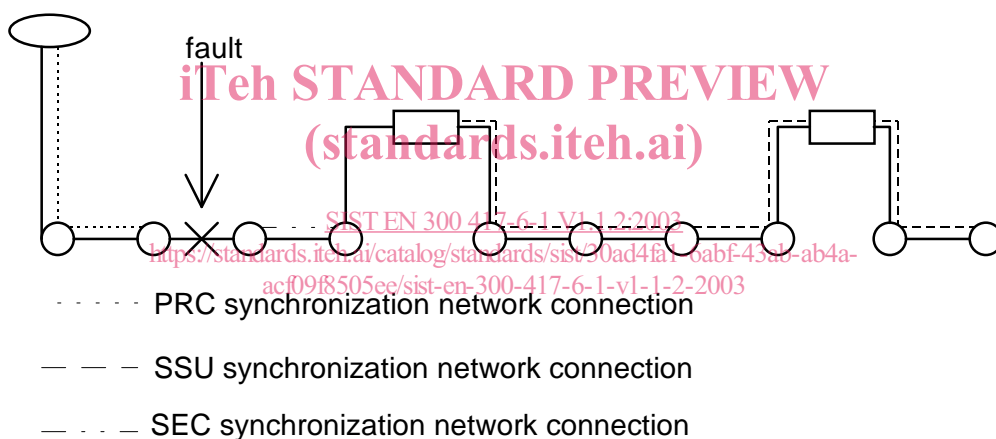

Figure 3: Representation of the synchronization network connection in case of failure

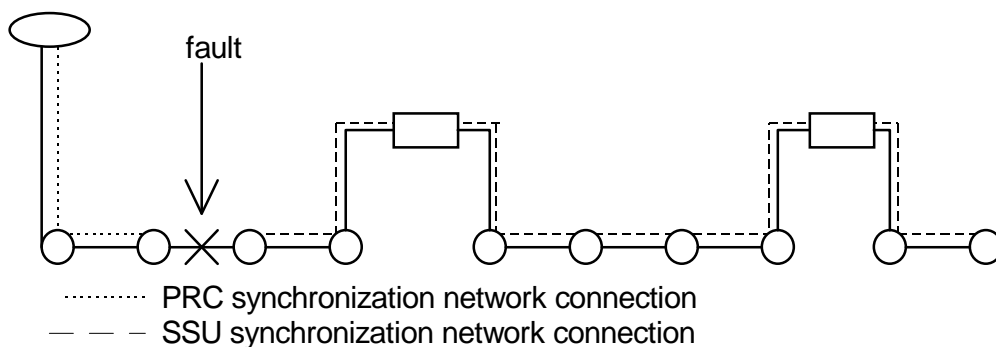

Figure 4: Example of restoration of the synchronization (see figure 7 of EN 300 462-2-1 [9])

## 4.2 Synchronization distribution trails

SD trails transport timing between two adjacent equipments.

From a synchronization view point, adjacent NEs are those NEs that are interconnected via section signals. Between two such adjacent NEs a uni-directional SD trail exists.

A **SD trail** starts at the input of the SD\_TT\_So function and ends at the output of the SD\_TT\_Sk function.

A **SD link connection** transports synchronization TI between two adjacent Connection Points (CP) of the NS\_C function.

A **NS network connection** transports synchronization TI over a series of synchronization link connection.

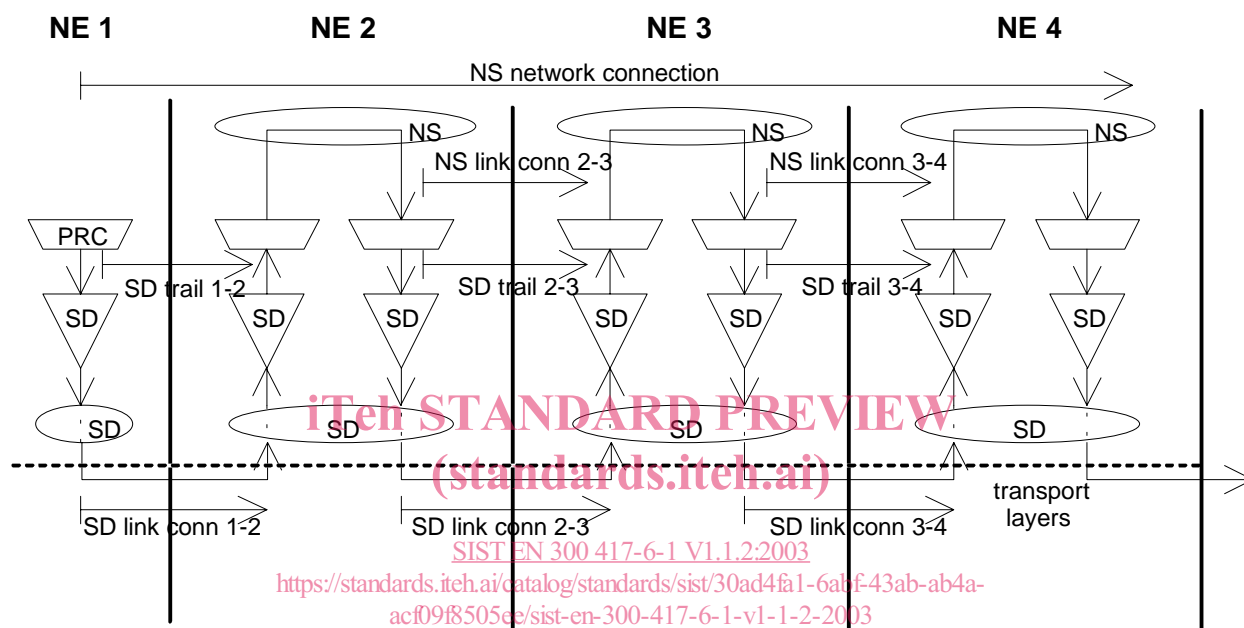

Figure 5: Example of series of SD network connection transporting PRC quality timing reference information

## 4.3 Synchronization interfaces

Synchronization trails can be carried through the network by a number of interfaces. Currently, the following signals are defined for such transport (refer also to figures B.1 to B.4):

- without traffic:
  - 2 048 kHz (T12);
  - 2 048 kbit/s (E12+P12s);
- with traffic:
  - 2 488 320 kbit/s (OS16+RS16+MS16);
  - 622 080 kbit/s (OS4+RS4+MS4);
  - 155 520 kbit/s (OS1 (or ES1)+RS1+MS1);
  - 139 264 kbit/s (E4+P4s);
  - 34 368 kbit/s (E31+P31s);
  - 2 048 kbit/s (E12+P12s).