**Rubber, vulcanized or
thermoplastic — Determination of
abrasion resistance using a rotating
cylindrical drum device**

*Caoutchouc vulcanisé ou thermoplastique — Détermination de la
résistance à l'abrasion à l'aide d'un dispositif à tambour tournant*

iTeh Standards

(<https://standards.iteh.ai>)

Document Preview

[ISO 4649:2017](#)

<https://standards.iteh.ai/catalog/standards/iso/adb16c10-377c-43bb-9750-101ae7d760ca/iso-4649-2017>



iTeh Standards
(<https://standards.iteh.ai>)
Document Preview

[ISO 4649:2017](https://standards.iteh.ai/catalog/standards/iso/adb16c10-377c-43bb-9750-101ae7d760ca/iso-4649-2017)

<https://standards.iteh.ai/catalog/standards/iso/adb16c10-377c-43bb-9750-101ae7d760ca/iso-4649-2017>



COPYRIGHT PROTECTED DOCUMENT

© ISO 2017, Published in Switzerland

All rights reserved. Unless otherwise specified, no part of this publication may be reproduced or utilized otherwise in any form or by any means, electronic or mechanical, including photocopying, or posting on the internet or an intranet, without prior written permission. Permission can be requested from either ISO at the address below or ISO's member body in the country of the requester.

ISO copyright office
Ch. de Blandonnet 8 • CP 401
CH-1214 Vernier, Geneva, Switzerland
Tel. +41 22 749 01 11
Fax +41 22 749 09 47
copyright@iso.org
www.iso.org

Contents

Page

Foreword	iv
Introduction	v
1 Scope	1
2 Normative references	1
3 Terms and definitions	1
4 Principle	2
5 Apparatus and materials	4
6 Calibration	5
7 Test pieces	5
7.1 Type and preparation.....	5
7.2 Number.....	6
7.3 Time interval between vulcanization or forming and testing.....	6
7.4 Conditioning.....	6
8 Test temperature	6
9 Procedure	6
9.1 General test procedure.....	6
9.2 Comparison against standard reference compounds or user-defined reference compounds.....	7
9.3 Density.....	8
10 Expression of results	8
10.1 General.....	8
10.2 Relative volume loss, ΔV_{rel}	8
10.3 Abrasion resistance index.....	9
11 Precision	9
12 Test report	9
Annex A (normative) Suitable abrasive sheet	10
Annex B (normative) Standard and user-defined reference compounds	11
Annex C (normative) Calibration schedule	16
Annex D (informative) Precision and bias	19
Bibliography	21

Foreword

ISO (the International Organization for Standardization) is a worldwide federation of national standards bodies (ISO member bodies). The work of preparing International Standards is normally carried out through ISO technical committees. Each member body interested in a subject for which a technical committee has been established has the right to be represented on that committee. International organizations, governmental and non-governmental, in liaison with ISO, also take part in the work. ISO collaborates closely with the International Electrotechnical Commission (IEC) on all matters of electrotechnical standardization.

The procedures used to develop this document and those intended for its further maintenance are described in the ISO/IEC Directives, Part 1. In particular the different approval criteria needed for the different types of ISO documents should be noted. This document was drafted in accordance with the editorial rules of the ISO/IEC Directives, Part 2 (see www.iso.org/directives).

Attention is drawn to the possibility that some of the elements of this document may be the subject of patent rights. ISO shall not be held responsible for identifying any or all such patent rights. Details of any patent rights identified during the development of the document will be in the Introduction and/or on the ISO list of patent declarations received (see www.iso.org/patents).

Any trade name used in this document is information given for the convenience of users and does not constitute an endorsement.

For an explanation on the voluntary nature of standards, the meaning of ISO specific terms and expressions related to conformity assessment, as well as information about ISO's adherence to the World Trade Organization (WTO) principles in the Technical Barriers to Trade (TBT) see the following URL: www.iso.org/iso/foreword.html.

This document was prepared by Technical Committee ISO/TC 45, *Rubber and rubber products*, Subcommittee SC 2, *Testing and analysis*.

This fourth edition cancels and replaces the third edition (ISO 4649:2010), which has been technically revised.

The main changes compared to the previous edition are as follows:

- the normative references have been updated;
- details regarding relative volume loss (3.2) have been added;
- the text has been updated for a better understanding.

Introduction

Various types of laboratory test equipment for wear resistance of rubber compound have been developed depending on the products to which rubber compounds have been applied in the past. Methods and equipment are briefly introduced in ISO 23794 and the test method using a rotating cylindrical drum device is described in detail in this document.

Because factors such as the grade of abrasive sheet, the type of adhesive used in the manufacture of the sheet and contamination and wear caused by previous testing lead to variations in the absolute values of abrasion loss, all tests are comparative. Runs with a reference compound are included so that the results can be expressed either as a relative volume loss compared to a calibrated abrasive sheet or as an abrasion resistance index compared to a reference compound.

This document describes two methods and specifies two standard reference compounds that can be chosen freely, although some combinations are more frequently used in practice. Considerable experience has been accumulated using the relative volume loss calculation in [10.2](#) for method A with reference compound no. 1 and method B with reference compounds no. 1 and no. 2.

When using standard reference compound no. 1 with a non-rotating test piece, a very important part of the method is the preparation of the abrasive sheet and its calibration.

Relative volume loss can be calculated for either test method with another reference compound, if the defined mass loss is known.

iTeh Standards
(<https://standards.iteh.ai>)
Document Preview

[ISO 4649:2017](#)

<https://standards.iteh.ai/catalog/standards/iso/adb16c10-377c-43bb-9750-101ae7d760ca/iso-4649-2017>

Rubber, vulcanized or thermoplastic — Determination of abrasion resistance using a rotating cylindrical drum device

WARNING 1 — Persons using this document should be familiar with normal laboratory practice. This document does not purport to address all of the safety problems, if any, associated with its use. It is the responsibility of the user to establish appropriate safety and health practices and to determine the applicability of any other restrictions.

WARNING 2 — Certain procedures specified in this document might involve the use or generation of substances or the generation of waste, that could constitute a local environmental hazard. Reference should be made to appropriate documentation on safe handling and disposal after use.

1 Scope

This document specifies two methods for the determination of the resistance of rubber to abrasion by means of a rotating cylindrical drum device.

The methods involve determination of the volume loss due to the abrasive action of rubbing a test piece over a specified grade of abrasive sheet. Method A is for a non-rotating test piece and method B is for a rotating test piece. For each method, the result can be reported as a relative volume loss or an abrasion resistance index.

These test methods are suitable for comparative testing, quality control, specification compliance testing, referee purposes and research and development work. No close relation between the results of this abrasion test and service performance can be inferred.

NOTE The abrasion loss is often more uniform using the rotating test piece because the whole surface of the test piece is in contact with the abrasive sheet over the duration of the test. However, there is considerable experience using the non-rotating test piece.

<https://standards.iteh.ai/catalog/standards/iso/adbl6c10-377c-43bb-9750-101ae7d760ca/iso-4649-2017>

2 Normative references

The following documents are referred to in the text in such a way that some or all of their content constitutes requirements of this document. For dated references, only the edition cited applies. For undated references, the latest edition of the referenced document (including any amendments) applies.

ISO 2230, *Rubber products — Guidelines for storage*

ISO 2393, *Rubber test mixes — Preparation, mixing and vulcanization — Equipment and procedures*

ISO 2781, *Rubber, vulcanized or thermoplastic — Determination of density*

ISO 7619-1, *Rubber, vulcanized or thermoplastic — Determination of indentation hardness — Part 1: Durometer method (Shore hardness)*

ISO 9298:2017, *Rubber compounding ingredients — Zinc oxide — Test methods*

ISO 18899:2013, *Rubber — Guide to the calibration of test equipment*

ISO 23529, *Rubber — General procedures for preparing and conditioning test pieces for physical test methods*

3 Terms and definitions

For the purposes of this document, the following terms and definitions apply.

ISO and IEC maintain terminological databases for use in standardization at the following addresses:

- IEC Electropedia: available at <http://www.electropedia.org/>
- ISO Online browsing platform: available at <http://www.iso.org/obp>

3.1

abrasion resistance

resistance to wear by mechanical action upon a surface

Note 1 to entry: For the purposes of this document, the abrasion resistance is expressed either as a *relative volume loss* (3.2) compared to an abrasive sheet calibrated using a standard reference compound or as an *abrasion resistance index* (3.3) compared to a reference compound.

3.2

relative volume loss

ΔV_{rel}

volume loss of the test rubber after being subjected to abrasion by an abrasive sheet which will cause a reference compound to lose a defined mass under the same specified conditions of test

Note 1 to entry: Relative volume loss is expressed in cubic millimetres.

3.3

abrasion resistance index

ARI

I_{AR}

ratio of the volume loss of a reference compound to the volume loss of the test rubber, measured under the same specified conditions of test

Note 1 to entry: A smaller number indicates a lower *abrasion resistance* (3.1).

Note 2 to entry: The abrasion resistance index is expressed as a percentage.

4 Principle

A cylindrical rubber test piece is made to slide over an abrasive sheet of specified abrasive grade under a specified pressure over a given distance. The test piece may be rotating or non-rotating during the test. The abrasive sheet is attached to a rotating cylindrical rotating drum against which the test piece is held and across which it traverses.

The loss of mass of the test piece is determined and used together with the density of the test piece material to calculate the volume loss. The volume loss of the test piece is compared to that of a reference compound tested under the same conditions.

Dimensions in millimetres

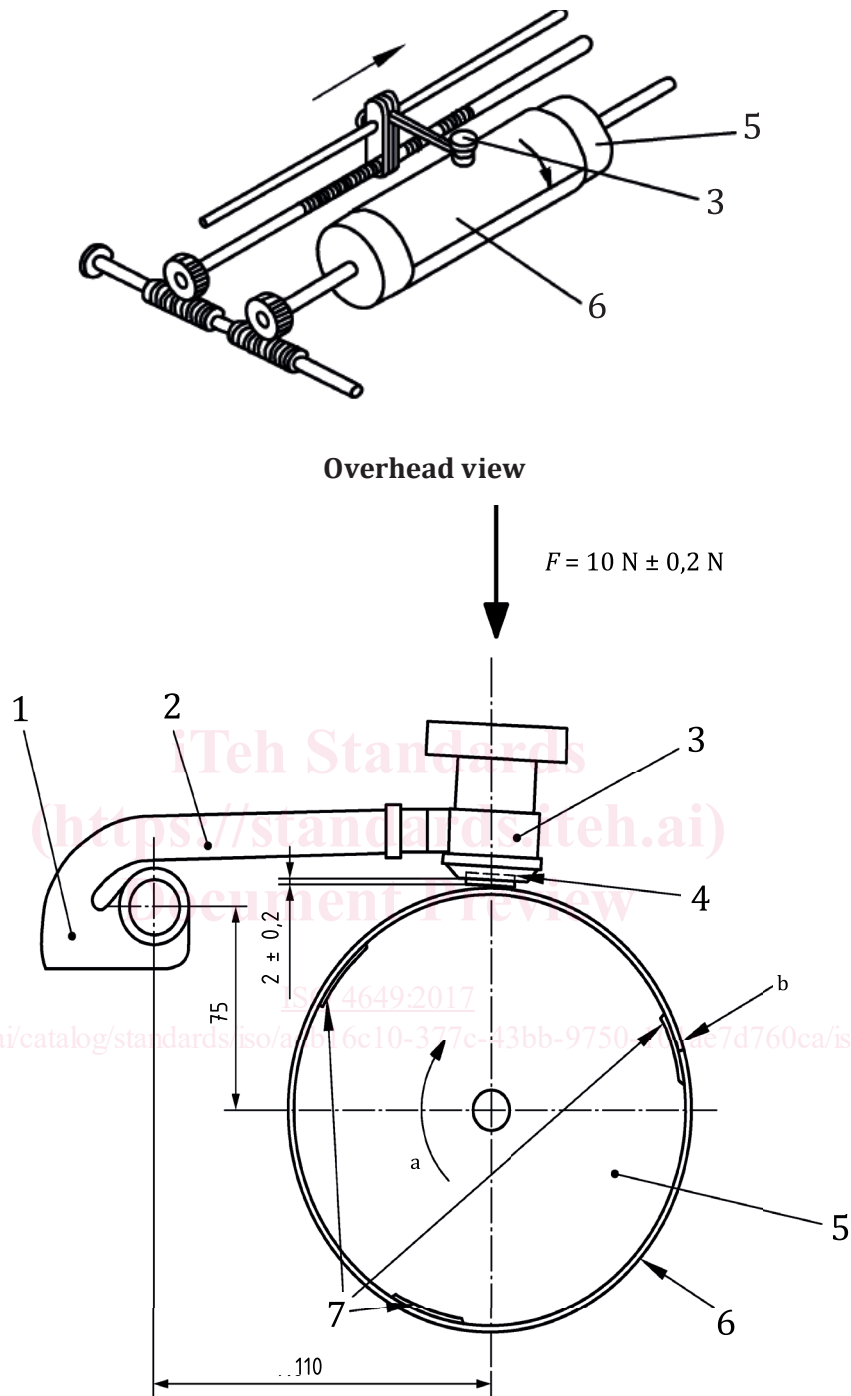

Key

- | | | | |
|---|---|----------|--------------------------------------|
| 1 | sledge | 6 | abrasive sheet |
| 2 | swivel arm | 7 | double-sided adhesive tape |
| 3 | test piece holder | <i>F</i> | vertical force |
| 4 | test piece | <i>a</i> | Rotational speed 40 r/min ± 1 r/min. |
| 5 | cylinder, diameter 150 mm ± 0,2 mm, length 500 mm | <i>b</i> | Gap of size ≤ 2 mm. |

Figure 1 — Schematic illustration of apparatus

5 Apparatus and materials

5.1 Abrasion machine.

The test apparatus (see [Figure 1](#)) consists of a laterally movable test piece holder and a rotatable cylinder to which the abrasive sheet ([5.2](#)) is fixed.

The cylinder shall have a diameter of $150 \text{ mm} \pm 0,2 \text{ mm}$ and a length of about 500 mm and shall be rotated at a speed of $40 \text{ r/min} \pm 1 \text{ r/min}$, the direction of rotation being as indicated in [Figure 1](#).

The test piece holder shall have a cylindrical opening, the diameter of which can be adjusted from 15,5 mm to 16,3 mm and a device for adjusting the length of the test piece protruding from the opening to $2 \text{ mm} \pm 0,2 \text{ mm}$. The holder shall be mounted on a swivel arm that, in turn, is attached to a sledge that can be moved laterally on a spindle. The lateral displacement of the holder shall be $4,20 \text{ mm} \pm 0,04 \text{ mm}$ per revolution of the drum (see Note 1). Suitable attachments may be provided to rotate the test piece during the test run by rotation of the test piece holder (method B), preferably at the rate of 1 revolution per 50 revolutions of the drum.

NOTE 1 With this lateral movement, the test piece passes over any one area of the abrasive sheet four times.

The swivel arm and test piece holder shall be free from vibration during operation and so disposed that the test piece is pressed against the drum with a vertical force of $10 \text{ N} \pm 0,2 \text{ N}$. For investigation of extremely soft or hard materials, the force may be changed to $5 \text{ N} \pm 0,1 \text{ N}$ or $20 \text{ N} \pm 0,4 \text{ N}$, respectively (see Note 2). The force is generated by adding masses to the top of the test piece holder.

NOTE 2 A force of 5 N is typically used for rubbers softer than approximately 40 IRHD and a force of 20 N is used for hard rubbers of 80 IRHD and above.

The abrasive sheet shall be attached to the drum using three evenly spaced strips of double-sided adhesive tape extending along the complete length of the drum. The width of the margins that are not touched by the test piece shall be equal. Care shall be taken to ensure that the abrasive sheet is firmly held so as to present a uniform abrasive surface over the whole area of the cylinder. One of the strips shall be placed where the ends of the abrasive sheet meet. Ideally, the ends should meet exactly, but any gap left between them shall not exceed 2 mm. The adhesive tape shall be about 50 mm wide and not more than 0,2 mm thick.

The abrasion run starts by bringing the test piece into contact with the abrasion sheet.

Placement of the test piece on the sheet at the beginning of a test run and its removal after an abrasion run of $40 \text{ m} \pm 0,2 \text{ m}$ (equivalent to 84 revolutions) shall be automatic. In special cases of very high volume loss of the test piece, the abrasion distance may be reduced to $20 \text{ m} \pm 0,1 \text{ m}$ (equivalent to 42 revolutions). In that case, a revolution counter or automatic stopping device should preferably be used.

NOTE 3 For rubbers with very high mass loss, a distance of 10 m has been used.

To protect the abrasive sheet from damage by the test piece holder, a device for switching off the apparatus just before the lower edge of the test piece holder touches the sheet is recommended.

The test machine may be equipped with a vacuum hose and a brush to aid in the removal of debris from the machine.

5.2 Abrasive sheet.

An abrasive sheet made with aluminium oxide of grain size 60, at least 400 mm wide, $474 \text{ mm} \pm 1 \text{ mm}$ long and 1 mm average thickness, shall be used as the abrasive medium.

In a test using a non-rotating test piece (method A) of standard reference compound no. 1 (see [Table B.1](#)), this abrasive sheet shall cause a mass loss of between 180 mg and 220 mg for an abrasion distance of 40 m.

When each new sheet is first used, the direction of motion shall be indicated on the sheet, as it is important that the same direction be used for all subsequent test runs.