**Rubber, vulcanized or
thermoplastic — Determination of
shear modulus and adhesion to rigid
plates — Quadruple-shear methods**

*Caoutchouc vulcanisé ou thermoplastique — Détermination du
module de cisaillement et de la force d'adhérence à des plaques
rigides — Méthodes du quadruple cisaillement*

iTeh STANDARD PREVIEW
(standards.iteh.ai)

ISO 1827:2016

<https://standards.iteh.ai/catalog/standards/sist/de461225-08bc-43ab-b6b6-2c076f07ec9f/iso-1827-2016>



iTeh STANDARD PREVIEW
(standards.iteh.ai)

ISO 1827:2016

<https://standards.iteh.ai/catalog/standards/sist/de461225-08bc-43ab-b6b6-2c076f07ec9f/iso-1827-2016>



COPYRIGHT PROTECTED DOCUMENT

© ISO 2016, Published in Switzerland

All rights reserved. Unless otherwise specified, no part of this publication may be reproduced or utilized otherwise in any form or by any means, electronic or mechanical, including photocopying, or posting on the internet or an intranet, without prior written permission. Permission can be requested from either ISO at the address below or ISO's member body in the country of the requester.

ISO copyright office
Ch. de Blandonnet 8 • CP 401
CH-1214 Vernier, Geneva, Switzerland
Tel. +41 22 749 01 11
Fax +41 22 749 09 47
copyright@iso.org
www.iso.org

Contents

	Page
Foreword.....	iv
1 Scope	1
2 Normative references	1
3 Terms and definitions	1
4 Principle	2
4.1 Method A — Determination of the shear modulus.....	2
4.2 Method B — Determination of the adhesion.....	2
5 Apparatus	2
6 Calibration	2
7 Test piece	2
7.1 Shape and dimensions.....	2
7.2 Preparation.....	3
7.2.1 Preparation of rigid plates.....	3
7.2.2 Preparation using un moulded rubber.....	3
7.2.3 Preparation using pre-moulded rubber.....	3
7.3 Number of test pieces.....	4
8 Time interval between vulcanization and testing	4
9 Conditioning	4
10 Temperature of test	4
11 Procedure	4
11.1 Method A.....	4
11.2 Method B.....	5
12 Expression of results	5
12.1 Method A.....	5
12.2 Method B.....	6
13 Test report	6
13.1 For method A.....	6
13.2 For method B.....	7
Annex A (normative) Calibration schedule	8

Foreword

ISO (the International Organization for Standardization) is a worldwide federation of national standards bodies (ISO member bodies). The work of preparing International Standards is normally carried out through ISO technical committees. Each member body interested in a subject for which a technical committee has been established has the right to be represented on that committee. International organizations, governmental and non-governmental, in liaison with ISO, also take part in the work. ISO collaborates closely with the International Electrotechnical Commission (IEC) on all matters of electrotechnical standardization.

The procedures used to develop this document and those intended for its further maintenance are described in the ISO/IEC Directives, Part 1. In particular the different approval criteria needed for the different types of ISO documents should be noted. This document was drafted in accordance with the editorial rules of the ISO/IEC Directives, Part 2 (see www.iso.org/directives).

Attention is drawn to the possibility that some of the elements of this document may be the subject of patent rights. ISO shall not be held responsible for identifying any or all such patent rights. Details of any patent rights identified during the development of the document will be in the Introduction and/or on the ISO list of patent declarations received (see www.iso.org/patents).

Any trade name used in this document is information given for the convenience of users and does not constitute an endorsement.

For an explanation on the meaning of ISO specific terms and expressions related to conformity assessment, as well as information about ISO's adherence to the World Trade Organization (WTO) principles in the Technical Barriers to Trade (TBT) see the following URL: www.iso.org/iso/foreword.html.

The committee responsible for this document is ISO/TC 45, *Rubber and rubber products*, Subcommittee SC 2, *Testing and analysis*.

This fifth edition cancels and replaces the fourth edition (ISO 1827:2011), which has been technically revised by changing symbols in [12.2.2](#).

ISO 1827:2016
and replaces the fourth edition (ISO 1827:2011), which has been technically revised by changing symbols in 12.2.2.
2c076f07ec9f/iso-1827-2016

Rubber, vulcanized or thermoplastic — Determination of shear modulus and adhesion to rigid plates — Quadruple-shear methods

WARNING — Persons using this document should be familiar with normal laboratory practice. This document does not purport to address all of the safety problems, if any, associated with its use. It is the responsibility of the user to establish appropriate safety and health practices and to ensure compliance with any national regulatory conditions.

IMPORTANT — Certain procedures specified in this document might involve the use or generation of substances, or the generation of waste, that could constitute a local environmental hazard. Reference should be made to appropriate documentation on safe handling and disposal after use.

1 Scope

This document specifies methods for the determination of the modulus in shear and the strength of bonds of rubber to metal or other rigid plates, using rubber bonded between four parallel plates.

Method A describes the determination of the modulus in shear.

Method B describes the determination of the strength of the bonds.

The methods are applicable primarily to test pieces prepared in the laboratory under standard conditions, such as can be used to provide data for the development and control of rubber compounds and methods of manufacture of bonded shear units.

2 Normative references

The following documents are referred to in the text in such a way that some or all of their content constitutes requirements of this document. For dated references, only the edition cited applies. For undated references, the latest edition of the referenced document (including any amendments) applies.

ISO 5893:2002, *Rubber and plastics test equipment — Tensile, flexural and compression types (constant rate of traverse) — Specification*

ISO 18899:2013, *Rubber — Guide to the calibration of test equipment*

ISO 23529, *Rubber — General procedures for preparing and conditioning test pieces for physical test methods*

3 Terms and definitions

For the purposes of this document, the following terms and definitions apply.

ISO and IEC maintain terminological databases for use in standardization at the following addresses:

- IEC Electropedia: available at <http://www.electropedia.org/>
- ISO Online browsing platform: available at <http://www.iso.org/obp>

3.1 shear modulus

applied shear stress, calculated with respect to the bonded area of the rubber in a test piece, divided by the resultant shear strain in the direction of application of the stress

Note 1 to entry: The shear strain (γ) is half the measured deformation divided by the thickness of one rubber block or element. The shear stress (τ) is the applied force divided by twice the area of a bonded face of one rubber block or element.

Note 2 to entry: The form of the test piece specified ensures that there is zero applied stress in the direction normal to the bonded surfaces, so that the deformation can be regarded as simple shear.

Note 3 to entry: This definition of shear modulus is sometimes referred to as the secant modulus.

4 Principle

4.1 Method A — Determination of the shear modulus

The force required to obtain a range of predetermined shear strains of a unit of standard dimensions comprising four parallelepipeds of rubber symmetrically disposed and bonded to four parallel rigid plates is measured, the forces being parallel to the bonding surfaces and, as a rule, non-destructive, i.e. of maximum values appreciably lower than the bond strength.

4.2 Method B — Determination of the adhesion

The force required to cause the rupture of a unit as described for method A is measured.

5 Apparatus

<https://standards.iteh.ai/catalog/standards/sist/de461225-08bc-43ab-b6b6-4190-1827-2016>
5.1 **Test machine**, complying with the requirements of ISO 5893, capable of measuring force with an accuracy corresponding to class 1, as defined in ISO 5893:2002, and with a rate of traverse of the moving grip of 5 mm/min (method A) or 50 mm/min (method B).

The test machine shall include apparatus to measure the deformation of the rubber of the test piece to an accuracy of 0,02 mm.

5.2 **Fixtures**, for holding the test pieces in the grips, provided with a universal joint to permit accurate centring of the line of action of the applied force.

5.3 **Environmental chamber**, suitable for carrying out tests at the temperature chosen or specified (see [Clause 10](#)), conforming to the requirements of ISO 23529.

6 Calibration

The test apparatus shall be calibrated in accordance with the schedule given in [Annex A](#).

7 Test piece

7.1 Shape and dimensions

The test piece shall consist of four identical parallelepipedic rubber elements 4 mm \pm 1 mm thick, 20 mm \pm 5 mm wide and 25 mm \pm 5 mm long, bonded on each of their two largest opposite faces to the mating faces of four rigid plates of the same width and of appropriate lengths to obtain a symmetrical double-sandwich arrangement, means being provided at the free external end of each central plate to

enable it to be attached to a holding fixture. The rigid plates shall be of sufficient thickness to withstand bending. A typical arrangement is shown in [Figure 1](#).

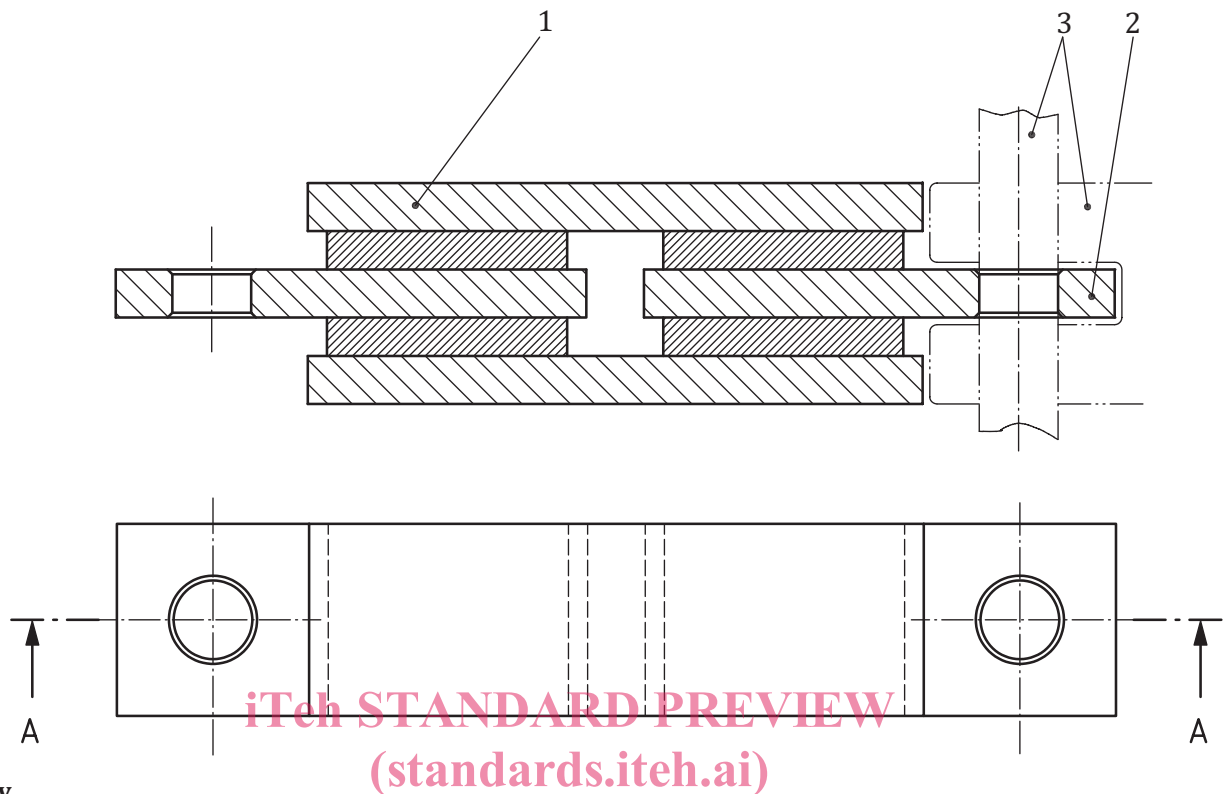

Key

- 1 two external plates
- 2 two internal plates
- 3 pin and fixture for tensile loading

Figure 1 — Test piece arrangement

7.2 Preparation

7.2.1 Preparation of rigid plates

Rectangular rigid plates of suitable dimensions shall be prepared and treated in accordance with the requirements of a suitable adhesive system.

7.2.2 Preparation using un moulded rubber

Prepared rigid plates and suitably sized rubber blanks shall be moulded either by compression or by transfer methods. The moulding shall be carried out using a time and temperature sequence appropriate to the rubber under test. At the conclusion of moulding, care shall be taken in removing the test pieces from the mould to avoid subjecting the adhered surfaces to undue stress.

7.2.3 Preparation using pre-moulded rubber

The four rubber elements for each test piece may be cut from a pre-moulded sheet of uniform thickness or from a rubber product. In either case, care shall be taken to ensure that all four elements are equal in all their dimensions to within $\pm 0,1$ mm.

The elements shall be bonded to the prepared rigid plates using an adhesive system giving a high-modulus bond.

7.3 Number of test pieces

The test shall be carried out on three (method A) or five (method B) test pieces.

8 Time interval between vulcanization and testing

Unless otherwise specified for technical reasons, the time interval between vulcanization and testing shall be in accordance with ISO 23529.

9 Conditioning

9.1 When a test is made at one of the standard laboratory temperatures specified in ISO 23529, the test piece shall be maintained at that condition for at least 3 h before the test.

9.2 When tests are made at subnormal or elevated temperatures, the test pieces shall be maintained at the conditions of test for a period of time sufficient to reach temperature equilibrium with the test environment, or for the period of time required by the specification covering the material or product being tested.

10 Temperature of test

Carry out the test at one of the temperatures specified in ISO 23529. Unless otherwise specified, one of the standard laboratory temperatures shall be used.

The same temperature shall be used for any series of tests intended to be comparable.

11 Procedure

ISO 1827:2016
<https://standards.iteh.ai/catalog/standards/sist/de461225-08bc-43ab-b6b6-2c076f07ec9f/iso-1827-2016>

11.1 Method A

11.1.1 Determine the dimensions of the rubber elements in the test piece. Where applicable, the requirements of ISO 23529 shall be met.

For test pieces prepared by vulcanization in a mould, the mould dimensions may be used to determine the area of each element. The thickness shall be determined, from measurements of the rigid plates and of the moulded test piece, by difference. For test pieces prepared from pre-moulded rubber elements, the dimensions of the elements shall be determined before bonding.

11.1.2 After conditioning as specified in [Clause 9](#), immediately mount the test piece in the test machine, taking care to ensure freedom of longitudinal self-alignment with the direction of force application.

For some applications, a mechanical conditioning procedure could be required. In such cases, apply five successive shear-loading cycles from 0 % to 30 %. During mechanical conditioning and subsequent testing, maintain the test piece at the test temperature.

11.1.3 When the test piece is mounted in the test machine, immediately zero the force-measuring and deformation-measuring apparatus while maintaining a slight traction force; for example, 1 % of the expected maximum force. Immediately apply an increasing traction force at a rate of separation of the jaws of 5 mm/min \pm 1 mm/min until a maximum shear strain of 30 % is reached, and record the force/deformation curve.

11.2 Method B

11.2.1 Determine the dimensions of the rubber elements in the test piece. Where applicable, the requirements of ISO 23529 shall be met.

For test pieces prepared by vulcanization in a mould, the mould dimensions may be used to determine the area of each element. The thickness shall be determined, from measurements of the rigid plates and of the moulded test piece, by difference.

For test pieces prepared from pre-moulded rubber elements, the dimensions of the elements shall be determined before bonding.

11.2.2 After conditioning as specified in [Clause 9](#), immediately mount the test piece in the test machine, taking care to ensure freedom of longitudinal self-alignment with the direction of force application.

Operate the test machine at a rate of separation of the jaws of 50 mm/min ± 5 mm/min until the test piece breaks. Record the maximum force.

Recover the broken pieces and examine the failure surfaces.

12 Expression of results

12.1 Method A

The shear modulus shall be determined at a shear strain of 25 %.

Calculate the shear strain, γ , from [Formula \(1\)](#):

$$\gamma = \frac{d}{2c} \quad \text{ISO 1827:2016} \quad (1)$$

<https://standards.iteh.ai/catalog/standards/sist/de461225-08bc-43ab-b6b6-2c076f07ec9f/iso-1827-2016>

where

d is the deformation, in millimetres, of the test piece;

c is the thickness, in millimetres, of one rubber element.

Calculate the deformation corresponding to 25 % shear strain, d_{25} , in millimetres, from [Formula \(2\)](#):

$$d_{25} = 0,25 \times 2c \quad (2)$$

From the force/deformation curve, determine the force needed to give 25 % shear strain, F_{25} .

Calculate the shear stress at 25 % strain, τ_{25} , in newtons per square millimetre, from [Formula \(3\)](#):

$$\tau_{25} = \frac{F_{25}}{2A} \quad (3)$$

where

F is the force, in newtons;

A is the bonded area, in square millimetres, of one face of one rubber element.