



~~Designation: F88-07a~~ Designation: F 88/F 88M - 09

## Standard Test Method for Seal Strength of Flexible Barrier Materials<sup>1</sup>

This standard is issued under the fixed designation F 88/F 88M; the number immediately following the designation indicates the year of original adoption or, in the case of revision, the year of last revision. A number in parentheses indicates the year of last reapproval. A superscript epsilon ( $\epsilon$ ) indicates an editorial change since the last revision or reapproval.

### 1. Scope

- 1.1 This test method covers the measurement of the strength of seals in flexible barrier materials.
- 1.2 The test may be conducted on seals between a flexible material and a rigid material.
- 1.3 Seals tested in accordance with this test method may be from any source, laboratory or commercial.
- 1.4 This test method measures the force required to separate a test strip of material containing the seal. It also identifies the mode of specimen failure.

~~1.5 The values stated in SI units are to be regarded as the standard. The values given in parentheses are for information only.~~

1.5 The values stated in either SI units or inch-pound units are to be regarded separately as standard. The values stated in each system may not be exact equivalents; therefore, each system shall be used independently of the other. Combining values from the two systems may result in non-conformance with the standard.

1.6 This standard does not purport to address all of the safety concerns, if any, associated with its use. It is the responsibility of the user of this standard to establish appropriate safety and health practices and determine the applicability of regulatory limitations prior to use.

### 2. Referenced Documents

2.1 *ASTM Standards:*<sup>2</sup>

D 882 Test Method for Tensile Properties of Thin Plastic Sheetings ~~D 1898 Practice for Sampling of Plastics~~

E 171 Specification for Atmospheres for Conditioning and Testing Flexible Barrier Materials

E 691 Practice for Conducting an Interlaboratory Study to Determine the Precision of a Test Method

### 3. Terminology

3.1 *Definitions:*

3.1.1 *average seal strength, n*—average force per unit width of seal required to separate progressively a flexible material from a rigid material or another flexible material, under the conditions of the test.

3.1.1.1 *Discussion*—The average force normally is calculated by the testing machine from the digitized plot of force versus grip travel. The plot starts from zero force after slack has been removed from the test strip. The initial ramp-up from zero to the force level required to peel the seal is not indicative of seal strength, and data from that part of the curve should not be included in the calculation of average strength, nor should the return to zero following complete failure of the specimen. The amount of data actually discarded on each end of the measured seal-profile curve must be the same for all tests within any set of comparisons of average seal strength (see 6.1.1 and 9.8.1).

3.1.2 *flexible, adj*—indicates a material with flexural strength and thickness permitting a turn back at an approximate 180 degree angle.

3.1.3 *maximum seal strength, n*—maximum force per unit width of seal required to separate progressively a flexible material from a rigid material or another flexible material, under the conditions of the test.

### 4. Significance and Use

4.1 Seal strength is a quantitative measure for use in process validation, process control, and capability. Seal strength is not only relevant to opening force and package integrity, but to measuring the packaging processes' ability to produce consistent seals. Seal strength at some minimum level is a necessary package requirement, and at times it is desirable to limit the strength of the seal to facilitate opening.

<sup>1</sup> This test method is under the jurisdiction of ASTM Committee F02 on Flexible Barrier Packaging and is the direct responsibility of Subcommittee F02.20 on Physical Properties.

Current edition approved Nov. 15, 2007; 2009. Published December 2007; July 2009. Originally approved in 1968. Last previous edition approved in 2007 as F 88 - 07a.

<sup>2</sup> For referenced ASTM standards, visit the ASTM website, www.astm.org, or contact ASTM Customer Service at service@astm.org. For *Annual Book of ASTM Standards* volume information, refer to the standard's Document Summary page on the ASTM website.

4.1.1 The maximum seal force is important information, but for some applications, average force to open the seal may be useful, and in those cases also should be reported.

4.2 A portion of the force measured when testing materials may be a bending component and not seal strength alone. A number of fixtures and techniques have been devised to hold samples at various angles to the pull direction to control this bending force. Because the effect of each of these on test results is varied, consistent use of one technique (Technique A, Technique B, or Technique C) throughout a test series is recommended. Examples of fixtures and techniques are illustrated in Fig. 1.

4.2.1 *Technique A: Unsupported*—Each tail of the specimen is secured in opposing grips and the seal remains unsupported while the test is being conducted.

4.2.2 *Technique B: Supported 90° (By Hand)*—Each tail of the specimen is secured in opposing grips and the seal remains hand-supported at a 90° perpendicular angle to the tails while the test is being conducted.

4.2.3 *Technique C: Supported 180°*—The least flexible tail is supported flat against a rigid alignment plate held in one grip. The more flexible tail is folded 180° over the seal and is held in the opposing grip while the test is being conducted.

**5. Interferences**

5.1 The value obtained for seal strength can be affected by properties of the specimen other than seal strength. These interferences are discussed in the annex.

**6. Apparatus**

6.1 *Tensile Testing Machine*—A testing machine of the constant rate-of-jaw-separation type. The machine shall be equipped with a weighing system that moves a maximum distance of 2 % of the specimen extension within the range being measured. The machine shall be equipped with a device for recording the tensile load and the amount of separation of the grips; both of these measuring systems shall be accurate to ±2 %. The rate of separation of the jaws shall be uniform and capable of adjustment from approximately 2008 to 300 mm (812 in. [200 to 12 in.]/min; 300 mm)/min. The gripping system shall be capable of minimizing specimen slippage and applying an even stress distribution to the specimen.

6.1.1 If calculation of average seal strength is required, the testing machine system shall have the capability to calculate its value over a specified range of grip travel programmable by the operator. Preferably, the machine shall have the capability also to plot the curve of force versus grip travel.

6.2 *Specimen Cutter*, conforming to the requirements of 5.4 of Test Methods D 882, sized to cut specimens to a width of 25 mm (0.984 in.), 15 mm (0.591 in.), or 25.4 mm (1.00 in.). Tolerance shall be ±0.5%, sized to cut specimens to a width of 0.984 in. [25 mm], 0.591 in. [15 mm], or 1.00 in. [25.4 mm]. Tolerance shall be ±0.5 %.

**7. Sampling**

7.1 The number of test specimens shall be chosen to permit an adequate determination of representative performance. Practice D1898 provides guidance for test specimen selection.

7.1 The number of test specimens shall be chosen to permit an adequate determination of representative performance.

7.2 Testing of samples with visual defects or other deviations from normality may or may not be appropriate depending on the purpose of the investigation. Indiscriminate elimination of defects can bias results.

**8. Aging and Conditioning**

8.1 In the absence of information showing that heat seal strength stability of the materials under test is reached in shorter times, condition and test sealed materials in accordance with Specification E 171, with a minimum conditioning time of 40 h or longer if shown to be required to reach stability.

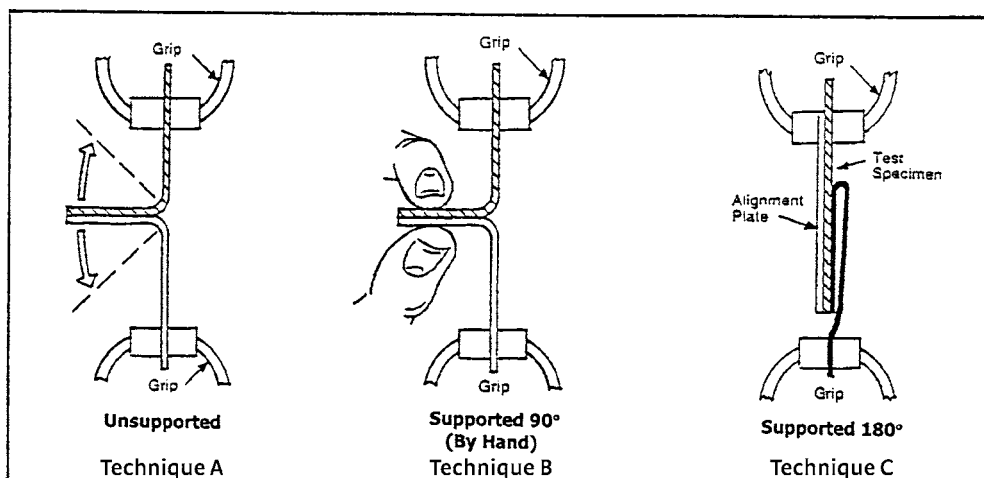

FIG. 1 Tail Holding Methods

8.2 Heat seal conditioning periods may be shortened to times determined by experimentation as sufficient to achieve seal strength stability.

8.3 Modification of conditioning practices may be necessary to meet specific test objectives, such as the measurement of seal strength at specified storage or handling temperature.

**9. Procedure**

9.1 Calibrate the tensile machine in accordance with the manufacturer’s recommendations.

9.2 Prepare sealed test specimens for testing by cutting to the dimensions shown in Fig. 2. Edges shall be clean-cut and perpendicular to the direction of seal. Specimen legs may be shorter than shown, depending on the grip dimensions of the testing machine.

9.3 Adhering to one tail-holding technique, clamp each leg of the test specimen in the tensile testing machine. The most rigid component of the specimen should be clamped in the top grip. The sealed area of the specimen shall be approximately equidistant between the grips. Recommended distance between grips (initial unconstrained specimen length) is:

Fin and Hot-Wire Seals		
— Highly <sup>A</sup> extensible materials	40 mm	(0.39 in.)
— Highly <sup>A</sup> extensible materials	0.39 in.	[10 mm]
— Less <sup>A</sup> extensible materials	25 mm	(1.0 in.)
— Less <sup>A</sup> extensible materials	1.0 in.	[25 mm]
Lap Seals	X + 10 mm <sup>B</sup>	

<sup>A</sup> Grip separation distance is recommended to be limited for highly extensible materials (100 + % elongation at seal failure) to minimize interferences (see annex).

<sup>B</sup> Refer to Fig. 2 for definition of X.

9.4 Center the specimen laterally in the grips. Align the specimen in the grips so the seal line is perpendicular to the direction of pull, allowing sufficient slack so the seal is not stressed prior to initiation of the test.

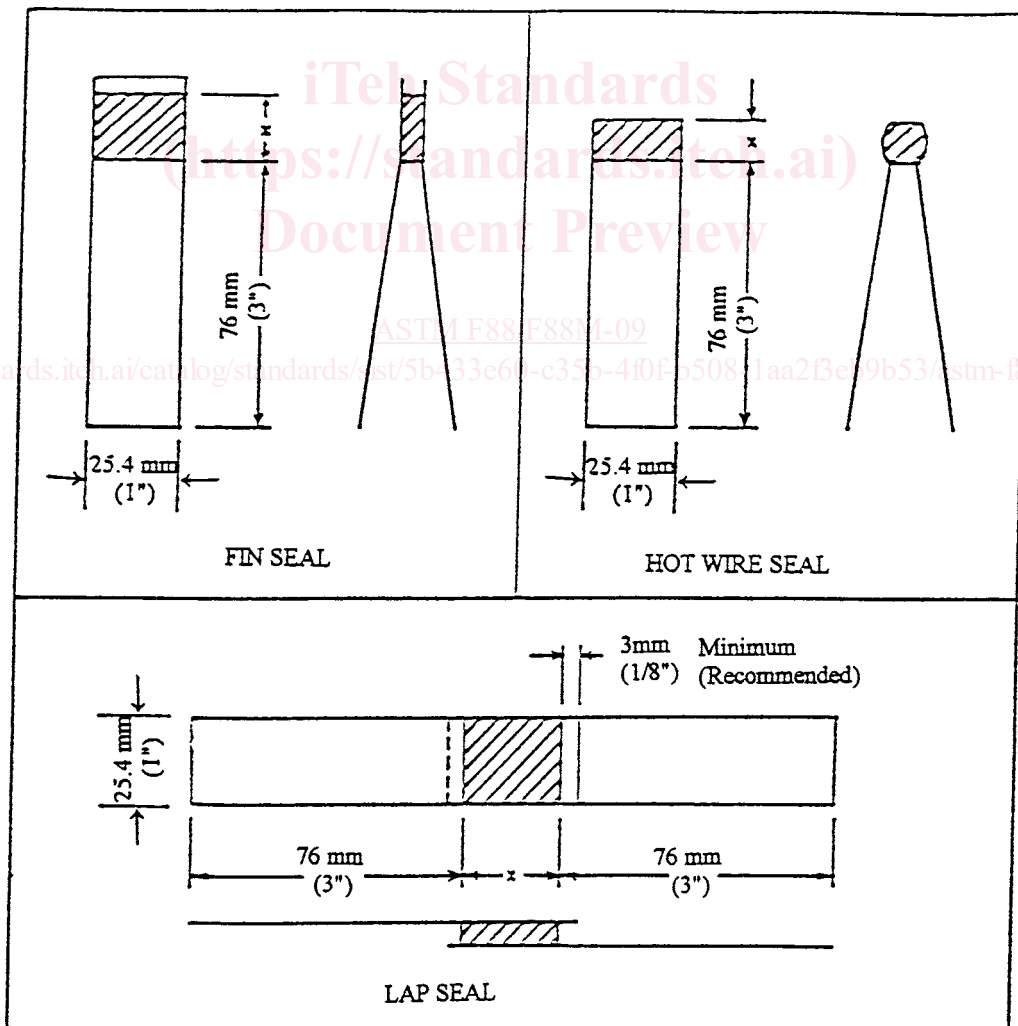

NOTE 1—Seal dimension marked X varies with sealer configuration.

**FIG. 2 Recommended Specimen Dimensions**

9.5 A significant difference in measured seal strength has been shown to result, depending on the orientation of a fin-seal tail during the test. The test report should indicate the details of any technique used to control tail orientation.

9.6 The seal shall be tested at a rate of grip separation of ~~200~~ to ~~300~~ mm/min. (~~8.12 in./min~~ [~~200 to 42 in./min~~], 300 mm/min).

9.7 For each cycle, report the maximum force encountered as the specimen is stressed to failure and identify the mode of specimen failure.

9.8 If the test strip peels apart in the seal area, either by adhesive failure, cohesive failure, or delamination, the average peel force may be an important index of performance and should be measured by the testing machine as a part of the test cycle.

9.8.1 Follow the machine manufacturer's instructions to select the desired algorithm for calculating average seal strength. Fig. 3 illustrates the effect of an algorithm that uses data only from the central 80 % of the curve to calculate the average.

9.8.2 If the test strip does not peel significantly in the seal area and failure is largely by breaking, tearing, or elongation of the substrate material, average force to failure may have little significance in describing seal performance and should not be reported in such cases (see Annex A1.1).

9.9 A plot of force versus grip travel may be useful as an aid in interpretation of results. In those cases, the testing machine should be programmed to generate the plot.

9.10 Other properties, such as energy to cause seal separation, may be appropriate in cases where grip travel results only in peel. When other failure modes (~~delamination, elongation, (elongation, break, tear, delamination (when not a designed peel seal separation mode)~~) or other) are present in addition to peel of the seal, energy, and other functions must be interpreted with caution.

## 10. Report

10.1 Report the following:

10.1.1 Complete identification of material being tested.

10.1.2 Equipment and test method or practice used to form seals, if known.

10.1.3 Equipment used to test seals.

10.1.4 Ambient conditions during tests; temperature and humidity.

10.1.5 Grip separation rate.

10.1.6 Initial grip separation distance.

10.1.7 Seal width.

10.1.8 Machine direction of material in relation to direction of pull.

10.1.9 Force (strength) values to three significant figures.

10.1.10 Technique of holding the tail (Technique A, B, or C) and any special fixtures used to hold specimens.

10.1.11 If the seal is made between two different materials, record which material is clamped in each grip.

10.1.12 Number of specimens tested and method of sampling.

10.1.13 Any other pertinent information that may affect test results.

10.1.14 Visual determination of mode of specimen failure. Frequently more than one mode will occur in the course of failure of an individual strip. Record all modes observed. A suggested classification of modes is (see Fig. 4):

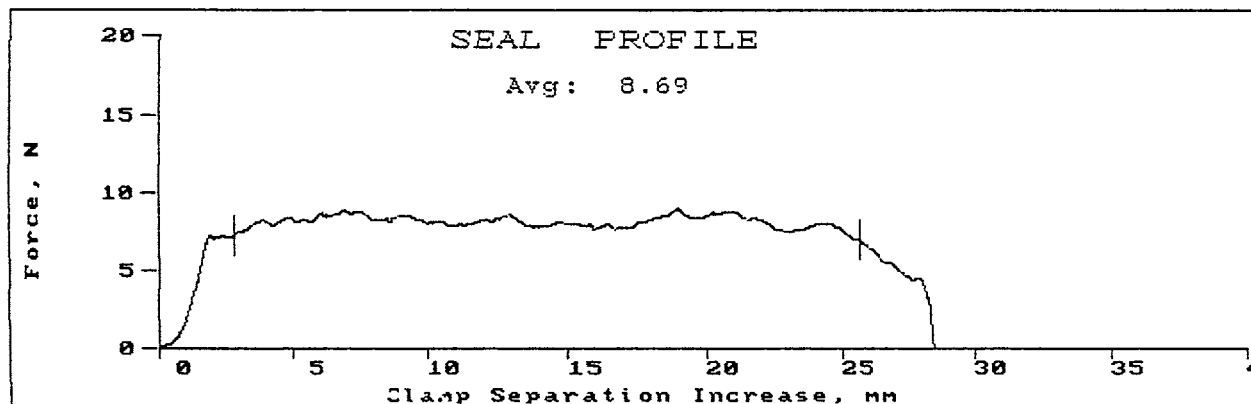

MARKERS ON SEAL PROFILE PLOT AT 10% AND 90%  
ESTABLISH DATA WINDOW OF 80% FOR CALCULATION

FIG. 3 Calculation of Average Seal Strength

**TABLE 1 Materials and Techniques**

Test Series "A" (MAXIMUM Values)
Heat Seal Coated 50# Basis Weight Paper sealed to Film (48 ga. PET/2 mil LDPE) Supported 90° @ 12 in./min Unsupported @ 12 in./min Unsupported @ 8 in./min
Test Series "B" (Both MAXIMUM Values and AVERAGE Peel Values were reported)
Uncoated 1073B Tyvek sealed to Film (48 ga. PET/2 mil LDPE) Supported 90° @ 12 in./min Unsupported @ 12 in./min Supported 180° @ 12 in./min Reverse direction of materials in grips @ 12 in./min
Test Series "C" (MAXIMUM Values)
Coex HDPE 3 mil film with peelable sealant layer sealed face-to-face Foil Composite 5 mil with same peelable sealant surface sealed face-to-face Unsupported @ 12 in./min Supported 180° @ 12 in./min

**TABLE 2 Test Equipment**

Manufacturer	Models	Load Cell		
		Nlb	lbN	
Dillon	AFG-50N	50	11.2	
Dillon	AFG-50N	50	11.2	50
Instron	4464, 5500R, 5564,	5 kN, 500,	112.4, 112.4,	
	5565, S5R1123,	100, 50, 9	22.5, 11.2, 2	
	4442, MN-44			
Instron	4464, 5500R, 5564,	112.4, 112.4,	5 kN, 500,	
	5565, S5R1123,	22.5, 11.2, 2	100, 50, 9	
	4442, MN-44			
Lloyd Instruments	1300-36	100	22.4	
Lloyd Instruments	1300-36	100	22.4	100
MTS Sintech Renew	4204	25	11.2	
MTS Sintech Renew	4204	25	11.2	
Test Resources	2000ZR	25	11.2	
Test Resources	2000ZR	25	11.2	
Thwing Albert	EJA	50	11.2	
Thwing Albert	EJA	50	11.2	50
Vinatoru Enterprises	CCT, HST	50	11.2	50

- Adhesive failure of the seal; peel.
- Cohesive failure of the material.
- Break or tear of material in seal area or at seal edge.
- Delamination of surface layer(s) from substrate.
- Elongation of material.
- Break or tear of material remote from seal.

10.1.15 Maximum force encountered as each specimen is stressed to failure, expressed preferably in Newtons/meter or lbf/in. of original specimen width. Gmf/in. and lbf/in. are commonly used.

10.1.16 *Average Peel Force*, if applicable (see 9.8)—If this measurement is reported, a statement of the method or algorithm used to calculate the average should be included.

10.1.17 Plot of force versus grip travel, if deemed significant in interpretation of results.

10.1.18 Other data not compromised by interferences, if such data are relevant to the specific test purpose.

10.1.19 Any statistical calculation deemed appropriate (most commonly mean, range, and standard deviation).

## 11. Precision and Bias

11.1 *Precision*—A round robin was conducted using Practice E 691 as a guide, involving 18 laboratories measuring a total of 1980 samples distributed over three different test groups of six laboratories each.<sup>3</sup> In order to maintain a focus on testing the method itself, laboratory samples were used to limit the amount of variation in the seals produced. Description of materials

<sup>3</sup> Supporting data have been filed at ASTM International Headquarters and may be obtained by requesting Research Report RR: F02-1023.

SEAL SEPARATION MODES

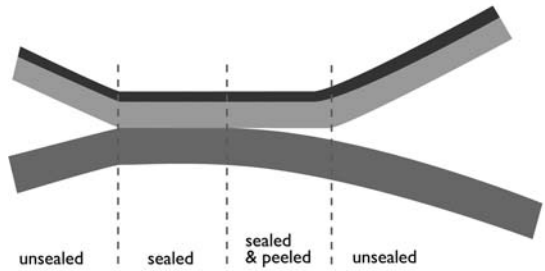

ADHESIVE PEEL

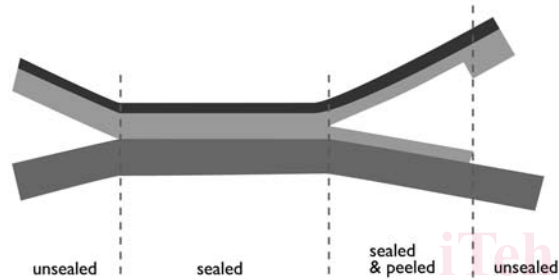

COHESIVE PEEL

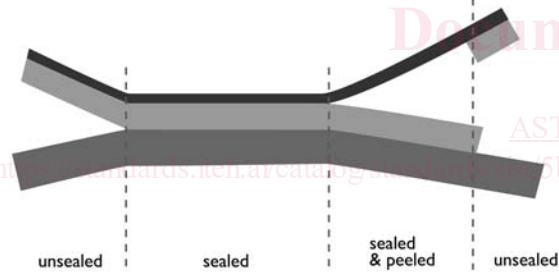

DELAMINATION

INTERFERENCES

Though the diagrams show only one web being affected, it is possible for either or both webs to partially or fully exhibit interferences. Delamination, when not a designed seal separation mode, is an interference.

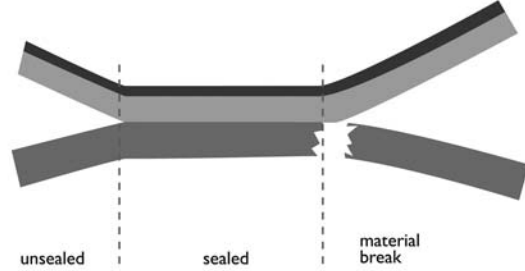

MATERIAL BREAK

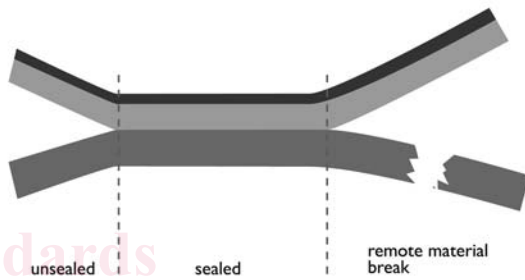

MATERIAL BREAK (REMOTE)

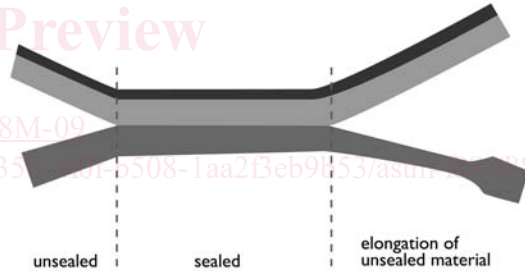

MATERIAL ELONGATION

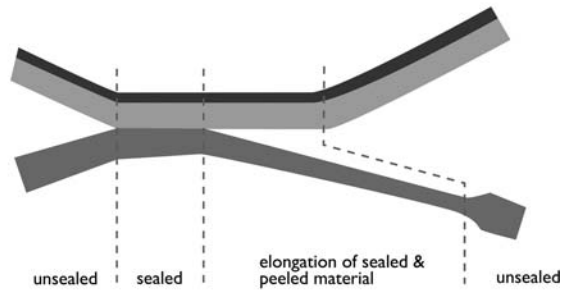

PEEL WITH ELONGATION

NOTE 1—Schematic representation of seal failure modes for seals between two webs. No diagram is included for systems including an adhesive as a third component.

FIG. 4 Test Strip Failure Modes