**Plastics — Polypropylene (PP) and
propylene-copolymer thermoplastics
— Determination of isotactic index**

*Plastiques — Thermoplastiques à base de polypropylène (PP) et de
copolymères de propylène — Détermination de l'indice d'isotacticité*

iTeh Standards
(<https://standards.iteh.ai>)
Document Preview

[ISO 9113:2019](https://standards.iteh.ai/catalog/standards/iso/6daa3d97-47a2-40e0-a4cc-5e78f5da0c74/iso-9113-2019)

<https://standards.iteh.ai/catalog/standards/iso/6daa3d97-47a2-40e0-a4cc-5e78f5da0c74/iso-9113-2019>



iTeh Standards
(<https://standards.iteh.ai>)
Document Preview

[ISO 9113:2019](https://standards.iteh.ai/catalog/standards/iso/6daa3d97-47a2-40e0-a4cc-5e78f5da0c74/iso-9113-2019)

<https://standards.iteh.ai/catalog/standards/iso/6daa3d97-47a2-40e0-a4cc-5e78f5da0c74/iso-9113-2019>



COPYRIGHT PROTECTED DOCUMENT

© ISO 2019

All rights reserved. Unless otherwise specified, or required in the context of its implementation, no part of this publication may be reproduced or utilized otherwise in any form or by any means, electronic or mechanical, including photocopying, or posting on the internet or an intranet, without prior written permission. Permission can be requested from either ISO at the address below or ISO's member body in the country of the requester.

ISO copyright office
CP 401 • Ch. de Blandonnet 8
CH-1214 Vernier, Geneva
Phone: +41 22 749 01 11
Fax: +41 22 749 09 47
Email: copyright@iso.org
Website: www.iso.org

Published in Switzerland

Contents

Page

Foreword.....	iv
1 Scope.....	1
2 Normative references.....	1
3 Terms and definitions.....	1
4 Apparatus.....	1
5 Procedure.....	3
5.1 Preparation of the sample.....	3
5.2 Determination.....	3
6 Calculation and expression of results.....	4
7 Calculation of isotactic index (II).....	4
8 Test report.....	5
Bibliography.....	6

iTeh Standards
 (https://standards.iteh.ai)
 Document Preview

ISO 9113:2019

<https://standards.iteh.ai/catalog/standards/iso/6daa3d97-47a2-40e0-a4cc-5e78f5da0c74/iso-9113-2019>

Foreword

ISO (the International Organization for Standardization) is a worldwide federation of national standards bodies (ISO member bodies). The work of preparing International Standards is normally carried out through ISO technical committees. Each member body interested in a subject for which a technical committee has been established has the right to be represented on that committee. International organizations, governmental and non-governmental, in liaison with ISO, also take part in the work. ISO collaborates closely with the International Electrotechnical Commission (IEC) on all matters of electrotechnical standardization.

The procedures used to develop this document and those intended for its further maintenance are described in the ISO/IEC Directives, Part 1. In particular, the different approval criteria needed for the different types of ISO documents should be noted. This document was drafted in accordance with the editorial rules of the ISO/IEC Directives, Part 2 (see www.iso.org/directives).

Attention is drawn to the possibility that some of the elements of this document may be the subject of patent rights. ISO shall not be held responsible for identifying any or all such patent rights. Details of any patent rights identified during the development of the document will be in the Introduction and/or on the ISO list of patent declarations received (see www.iso.org/patents).

Any trade name used in this document is information given for the convenience of users and does not constitute an endorsement.

For an explanation of the voluntary nature of standards, the meaning of ISO specific terms and expressions related to conformity assessment, as well as information about ISO's adherence to the World Trade Organization (WTO) principles in the Technical Barriers to Trade (TBT) see www.iso.org/iso/foreword.html.

This document was prepared by Technical Committee ISO/TC 61, *Plastics*, Subcommittee SC 9, *Thermoplastic materials*.

This second edition cancels and replaces the first edition (ISO 9113:1986), of which it constitutes a minor revision. The changes compared to the previous edition are as follows:

- the normative references have been updated;
- the mandatory [Clause 3](#) has been added and the subsequent clauses have been renumbered;
- minor editorial changes have been applied.

Any feedback or questions on this document should be directed to the user's national standards body. A complete listing of these bodies can be found at www.iso.org/members.html.

Plastics — Polypropylene (PP) and propylene-copolymer thermoplastics — Determination of isotactic index

1 Scope

This document specifies a method for determining the percentage of matter which can be extracted from crystalline propylene plastics by boiling *n*-heptane under standard conditions of testing. Isotactic index is determined by conventional chemical extraction as an absolute method.

This method provides for the identification and coding of types H, B and R propylene plastics according to ISO 19069-1[1].

This method is suitable only for base polymers and is not applicable for mixtures.

This method starts with solid propylene plastics in the form of particles of specified fineness.

2 Normative references

There are no normative references in this document.

3 Terms and definitions

No terms and definitions are listed in this document.

ISO and IEC maintain terminological databases for use in standardization at the following addresses:

— ISO Online browsing platform: available at <https://www.iso.org/obp>

— IEC Electropedia: available at <http://www.electropedia.org/>

4 Apparatus

4.1 Extractor, a type of which is shown in [Figure 1](#). Any other type of extractor giving the same results may be used. This extractor shall be suitable for use at the boiling point of *n*-heptane.

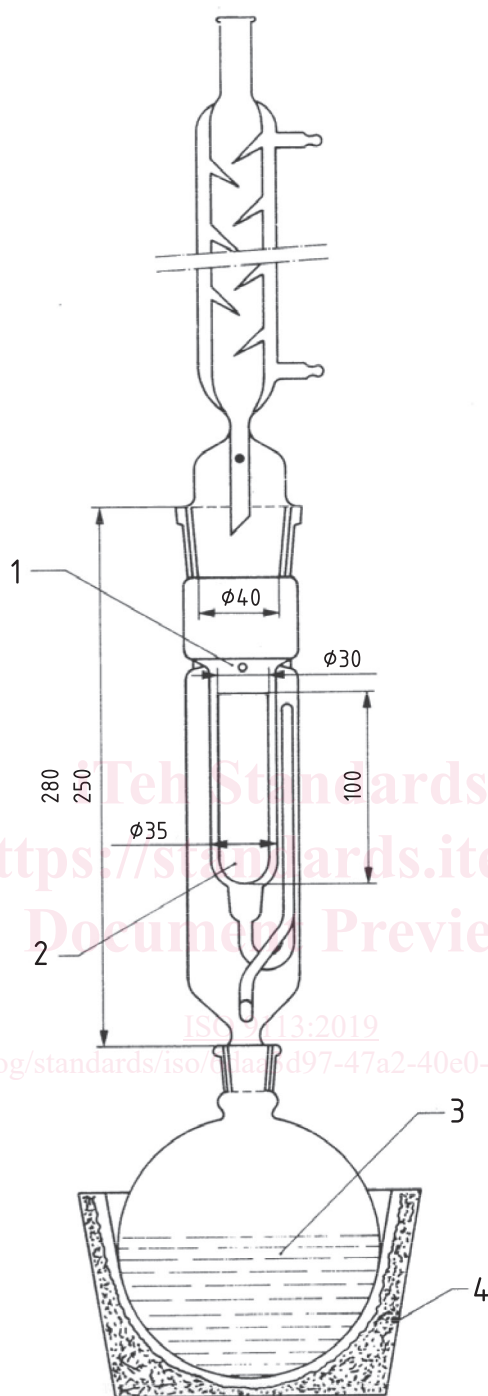

Key

- 1 extractor trap
- 2 cartridge
- 3 *n*-heptane
- 4 heater

Figure 1 — Extraction apparatus capable of receiving the cartridges described in 4.2

4.2 Glass fibre or paper cartridges (thimbles), with a diameter of 30 mm \pm 3 mm and length 100 mm \pm 10 mm.