



~~Designation: C878/C878M-03~~ Designation: C 878/C 878M - 09

Standard Test Method for Restrained Expansion of Shrinkage-Compensating Concrete¹

This standard is issued under the fixed designation C 878/C 878M; the number immediately following the designation indicates the year of original adoption or, in the case of revision, the year of last revision. A number in parentheses indicates the year of last reapproval. A superscript epsilon (ϵ) indicates an editorial change since the last revision or reapproval.

1. Scope*

1.1 This test method covers the determination of the expansion of concrete made with shrinkage-compensating cement.

1.2 The values stated in either SI units or inch-pound units are to be regarded separately as standard. The values stated in each system may not be exact equivalents; therefore, each system shall be used independently of the other. Combining values from the two systems may result in non-conformance with the standard.

1.3 ~~This standard does not purport to address all of the safety concerns, if any, associated with its use. It is the responsibility of the user of this standard to establish appropriate safety and health practices and determine the applicability of regulatory limitations prior to use.~~ This standard does not purport to address all of the safety concerns, if any, associated with its use. It is the responsibility of the user of this standard to establish appropriate safety and health practices and determine the applicability of regulatory limitations prior to use. (**Warning**—Fresh hydraulic cementitious mixtures are caustic and may cause chemical burns to skin and tissue upon prolonged exposure.²)

2. Referenced Documents

2.1 ASTM Standards:³

C 125 ~~Terminology Relating to Concrete and Concrete Aggregates~~

~~C157/C157M Test Method for Length Change of Hardened Hydraulic Cement, Mortar, and Concrete~~² Terminology Relating to Concrete and Concrete Aggregates

C 192/C 192M Practice for Making and Curing Concrete Test Specimens in the Laboratory

C 219 ~~Terminology Relating to Hydraulic Cement~~

~~C403/C403M Test Method for Time of Setting of Concrete Mixtures by Penetration Resistance~~² Terminology Relating to Hydraulic Cement

C 490 Practice for Use of Apparatus for the Determination of Length Change of Hardened Cement Paste, Mortar, and Concrete

C 670 Practice for Preparing Precision and Bias Statements for Test Methods for Construction Materials

C 806 Test Method for Restrained Expansion of Expansive Cement Mortar

C 845 Specification for Expansive Hydraulic Cement

2.2 ACI Standards and Committee Reports:⁴

116-R-90 Cement and Concrete Terminology

223-83 Standard Practice for the Use of Shrinkage-Compensating Concrete

3. Terminology

3.1 Terms used in this test method are defined in Terminology C 219, Terminology C 125, and ACI 116-R-90.

4. Significance and Use

4.1 Since the potential for expansion, under conditions of controlled restraint, of concrete made with shrinkage-compensating cement cannot always be satisfactorily predicted from tests of mortars made in accordance with Test Method C 806, a need has been recognized for a test method in which concrete specimens are tested.

¹ This method is under the jurisdiction of ASTM Committee C09 on Concrete and Concrete Aggregates and is the direct responsibility of Subcommittee C09.68 on Volume Change.

~~Current edition approved Jan. 10, 2003. Published April 2003. Originally approved in 1978. Last previous edition approved in 1995 as C878-95a.~~

~~Current edition approved June 15, 2009. Published July 2009. Originally approved in 1978. Last previous edition approved in 2003 as C 878-03.~~

² Annual Book of ASTM Standards, Vol 04.02.

² Section on Safety Precautions, *Manual of Aggregate and Concrete Testing*, Annual Book of ASTM Standards, Vol. 04.02.

³ For referenced ASTM standards, visit the ASTM website, www.astm.org, or contact ASTM Customer Service at service@astm.org. For Annual Book of ASTM Standards, Vol 04.01, volume information, refer to the standard's Document Summary page on the ASTM website.

⁴ Available from American Concrete Institute (ACI), P.O. Box 9094, Farmington Hills, MI 48333-9094, <http://www.concrete.org>.

*A Summary of Changes section appears at the end of this standard.

4.2 This test method can also be adapted readily to studies of expansion involving degrees of restraint, comparisons of cements, effects of cement contents, mixture proportions, schedules, or environmental treatments that differ from the standard procedures prescribed by this test method.

5. Apparatus

5.1 *Molds*, for casting test specimens, when used in conjunction with the restraining cage described in 4.2, shall provide for forming prisms 76 mm [3 in.] square with a gage length of 250 mm [10 in.]. The molds shall otherwise conform to the requirements for molds in Practice C 490, except that the stud holder, gage studs, and spacer screws described in that practice will not be used.

5.2 *Restraining Cage*, consisting of a threaded low-carbon steel rod (plain or zinc-coated) with steel end plates held in place by hex nuts as shown in Fig. 1. The hex nuts outside the cage shall be of stainless steel. Stainless steel cap nuts shall be put on each end of the rod. When tested in tension, within the elastic range, the rod shall have a strain of 2800 kN [0.0012 ± 0.0001/630 lbf] of load (Note 1).

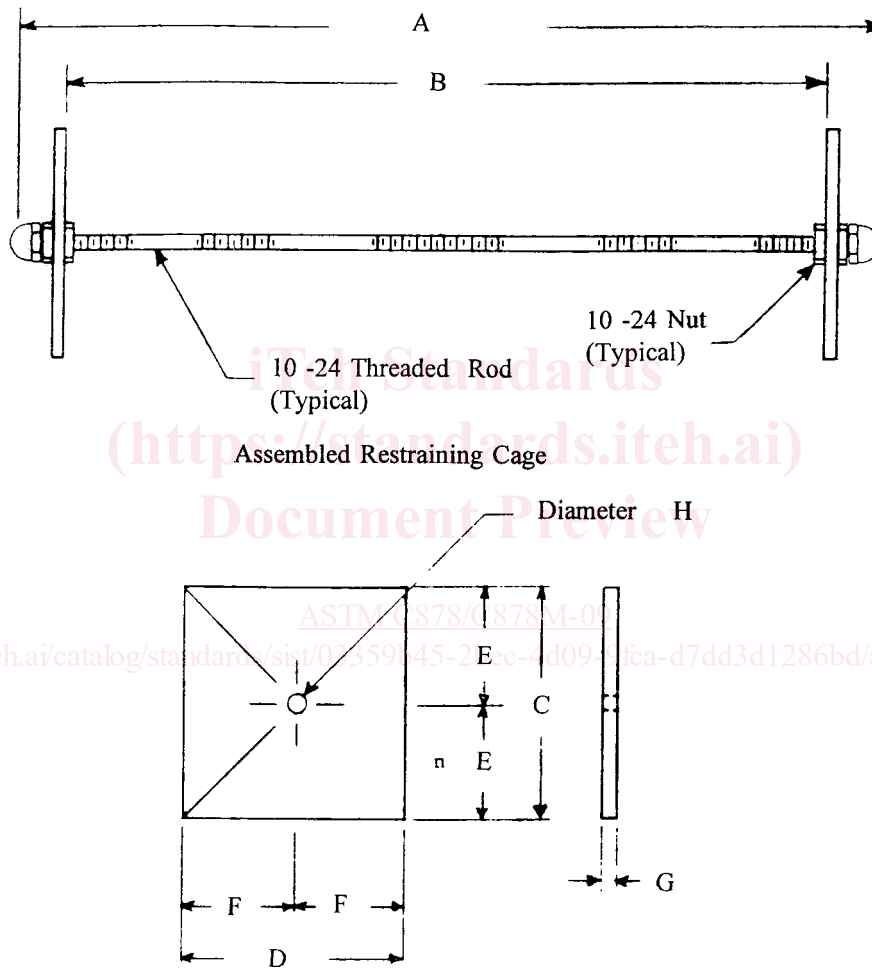

Measurement	Dimensions	
	in.	mm
A	11 ⁹ / ₁₆ ± 1/ ₁₆	294 ± 1.6
B	10	254 (gage length)
C	3	76
D	2 ³ / ₃₂ ± 1/ ₃₂	75 ± 1
E	1 ¹ / ₂	38
F	1 ³ / ₆₄	37.7
G	3/ ₆₄	10
H	3/ ₁₆	5

NOTE 1—All material is mild steel, except for stainless steel cap nuts.

FIG. 1 Restraining Cage

NOTE 1—It is intended that all rods used meet the indicated requirement for strain. When a large number of rods are obtained as a single lot, exercise judgment as to whether or not all must be tested. The designation “10-24” is used in ordinary rods having the desired properties.

5.3 *Length Comparator*, conforming to and to be used in accordance with the requirements of Practice C 490. Use a reference bar complying with the description given in Practice C 490. If the terminals of the comparator are fitted with collars, they shall be such that the cap nuts on the ends of the threaded rod of the specimen do not rest on the collar during the measuring (see Figs. 2 and 3).

5.4 *Tamping Rod*—The tamping rod shall be a straight steel rod, 10 mm [$\frac{3}{8}$ in.] in diameter, and no less than 250 mm [10 in.] in length, having at least the tamping end rounded to a hemispherical tip of the same diameter.

5.5 *Vibrators*, conforming to the requirements for external vibrators prescribed in Practice C 192/C 192M.

6. Test Specimen

6.1 The test specimen shall be a prism: 75 mm [3 in.] square with a gage length of 250 mm [10 in.] and an overall length (including the length of the rod and cap nuts) of approximately 290 mm [11.5 in.]. At least three specimens shall be prepared for each test.

NOTE 2—Use of aggregates of nominal maximum size greater than 25.0 mm [1 in.] may adversely affect the test results.

7. Preparation and Assembly of Specimen Molds and Restraining Cage

7.1 Install the cap nuts firmly in place on the ends of the restraining rods using a suitable adhesive to keep them from loosening when comparator readings are made (Note 3). The cap nuts should not be removed after the initial comparator reading of a specimen is made. Measure the restraining cage assembly length, including the cap nuts, while it is at 23.0 ± 2 °C [73.5 ± 3.5 °F]. This is to ensure it is 30 ± 2 mm [$1\frac{1}{16} \pm \frac{1}{16}$ in.]. The measurement taken at this time is used only to ensure that comparator readings can be made.

NOTE 3—A rapid-setting epoxy has been found suitable.

7.2 Thinly cover the edges of the restraining cage end plates that contact the sides and bottom of the mold with a heavy mineral oil or light cup grease such as petrolatum. After assembly of the molds, place a restraining cage in each mold compartment. Seal the contact lines between the outer sides and base plate of the molds with paraffin or micro-crystalline wax. Thinly cover the interior faces of the molds with mineral oil and remove any oil or grease from the restraining cage rod and end plates.

8. Procedure

8.1 *Preparation and Mixing of Materials*—Mixtures using job materials shall be made in the laboratory as described in Practice C 192/C 192M, except that the material temperatures shall be approximately those anticipated in the field. Mixing procedures shall

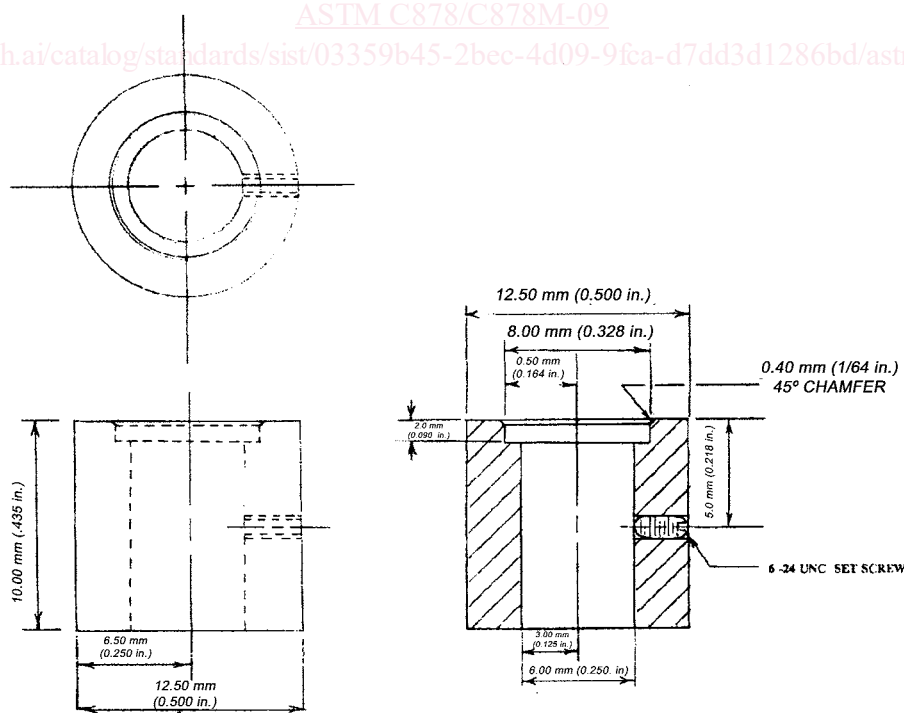

FIG. 2 Schematic of Upper and Lower Adjustable Restraining Collar for Length Comparator that Will Allow Positioning of Restraining Cage Cap Nuts to Rest on Anvils Without Interference from the Collars

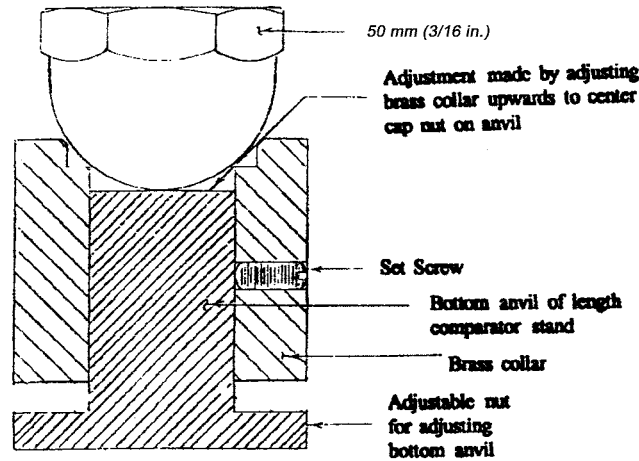

FIG. 3 Cross Section of Restraining Collar Showing Positioning of Cap Nut for Measurement

also reflect the actual mixing and delivery times expected for the particular work. Remove aggregate retained on the 25.0 mm [1 in.] sieve from that used in the mixture from which the specimens are to be molded. Select the mixture proportions according to applicable provisions of ACI 223-83.

8.2 *Molding Specimens*—Place the concrete in the mold in two approximately equal layers (the first layer shall just cover the threaded restraining rod) in accordance with the general instructions given for placing concrete in specimen molds given in Practice C 192/C 192M. Consolidate each layer by rodding or by external vibration in accordance with the instructions for consolidation of flexure test specimens given in Practice C 192/C 192M, except use the same method of consolidation for all specimens to be compared. The top layer shall slightly overfill the mold. After consolidation is complete, strike off the excess material with a straightedge and finish the exposed surface with a few strokes of a straight-edged trowel.

8.3 *Curing Specimens*—Cover the specimens with a polyethylene sheet or other suitable material to prevent loss or gain of moisture at the surface of the specimens.

8.4 Remove the specimens from the molds at the age of 6 h. In unusual cases the specimens may not be strong enough to demold at the age of 6 h. If this is the case, select a later time but demold as soon as practicable and report the demolding age with the results. Remove the specimens from the molds by loosening or removing the mold-fastening devices and gently tapping the base plate and side plates so as to free them from the specimens. Exercise great care in this operation, because of the fragility of the concrete at this age and in all later handling of specimens. Do not place specimens directly on hard wood or metal table tops. Placing a soft rubber mat over table tops to lessen impact force on specimens has been found to reduce scatter in data. Limit any marks placed on the specimens for identification or positioning to those made by graphite applied either by a soft pencil or as a liquid that deposits essentially graphite without binder, to those made with waterproof indelible ink, or to light scratchings in the surface of the concrete made with a sharp instrument.

8.5 *Measuring Specimens*—Take the initial comparator readings 30 ± 2 min after demolding. After the initial comparator reading, cure the specimens in lime-saturated water at 23 ± 2 °C [73.5 ± 3.5 °F] until they have reached an age of 7 days. At the end of the curing period take another comparator reading. It is permitted for comparator readings to be taken at intermediate ages between the initial comparator reading and the comparator reading at 7 days (Note 4).

NOTE 4—It is permitted to provide further water-curing, or alternatively the specimens shall be allowed to air-dry under any desired condition in order to determine later age length change data. Comparator readings shall be taken at any appropriate interval.

9. Calculation

9.1 Calculate the length changes as percent expansion or shrinkage as follows:

$$\text{Length change, \%} = \frac{[(\text{corrected comparator reading} - \text{corrected initial comparator reading}) / \text{gage length}] \times 100}{(1)}$$

where the corrected comparator reading is equal to the specimen comparator reading minus the reference bar comparator reading.

10. Report

10.1 Report the following information:

- 10.1.1 Identification of specimens, number of specimens for each condition, and date molded,
- 10.1.2 Source and identification of each material employed,