



Designation: ~~C1592-04~~ Designation: **C 1592/C 1592M – 09**

Standard Guide for ~~Nondestructive Assay Measurements~~ Making Quality Nondestructive Assay Measurements¹

This standard is issued under the fixed designation C 1592/C 1592M; the number immediately following the designation indicates the year of original adoption or, in the case of revision, the year of last revision. A number in parentheses indicates the year of last reapproval. A superscript epsilon (ϵ) indicates an editorial change since the last revision or reapproval.

1. Scope

1.1 This guide is a compendium of ~~Good Quality Measurement Practices~~ for performing measurements of radioactive material using nondestructive assay (NDA) instruments. The primary purpose of the guide is to assist its users in arriving at quality NDA results, that is, results that satisfy the end user's needs. This is accomplished by providing an acceptable and uniform basis for the collection, analysis, comparison, and application of data. The recommendations are not compulsory or prerequisites to achieving quality NDA measurements, but are considered contributory in most areas.

1.2 This guide applies to the use of NDA instrumentation for the measurement of nuclear materials by the observation of spontaneous or stimulated nuclear radiations, including photons, neutrons, or the flow of heat. Recommended calibration, operating, and assurance methods represent guiding principles based on current NDA technology. The diversity of industry-wide nuclear materials measurement applications and instrumentation precludes discussion of specific measurement situations. As a result, compliance with practices recommended in this guide must be based on a thorough understanding of contributing variables and performance requirements of the specific measurement application.

1.3 Selection of the best instrument for a given measurement application and advice on the use of this instrument must be provided by a qualified NDA professional following guidance provided in Guide C 1490. This guide is to be used as a reference, and to supplement the critical thinking, professional skill, expert judgement, and experimental test and verification needed to ensure that the instrumentation and methods have been properly implemented.

1.4 The intended audience for this guide includes but is not limited to Management, Auditor Support, NDA Qualified Instrument Operators, NDA Technical Specialists, and NDA Professionals.

1.5 The values stated in either SI units or inch-pound units are to be regarded separately as standard. The values stated in each system may not be exact equivalents; therefore, each system shall be used independently of the other. Combining values from the two systems may result in non-conformance with the standard.

2. Referenced Documents

2.1 ASTM Standards:²

~~E 859 Terminology Relating to Nuclear Materials~~

C 1030 Test Method for Determination of Plutonium Isotopic Composition by Gamma-Ray Spectrometry

C 1133 Test Method for Nondestructive Assay of Special Nuclear Material in Low-Density Scrap and Waste by Segmented Passive Gamma-Ray Scanning

C 1207 Test Method for Nondestructive Assay of Plutonium in Scrap and Waste by Passive Neutron Coincidence Counting

C 1215 Guide for Preparing and Interpreting Precision and Bias Statements in Test Method Standards ~~used~~ Used in the Nuclear Industry

C 1221 Test Method for Nondestructive Analysis of Special Nuclear Materials in ~~h~~Homogeneous Solutions by Gamma-Ray Spectrometry

C 1254 Test Method for Determination of Uranium in Mineral Acids by ~~X-ray~~X-Ray Fluorescence

C 1268 Test Method for Quantitative Determination of Americium 241 in Plutonium by Gamma-Ray Spectrometry

C 1316 Test Method for Nondestructive Assay of Nuclear Material in Scrap and Waste by Passive-Active Neutron Counting Using a ²⁵²Cf Shuffler

C 1455 ~~Guide~~Test Method for Nondestructive Assay of Special Nuclear Material Holdup Using Gamma-Ray Spectroscopic Methods

¹ This guide is under the jurisdiction of ASTM Committee C26 on Nuclear Fuel Cycle and is the direct responsibility of Subcommittee C26.10 on Non Destructive Assay. Current edition approved Feb. 1, 2004. Published March 2004.

Current edition approved June 1, 2009. Published July 2009. Originally approved in 2004. Last previous edition approved in 2004 as C 1592 – 04.

² For referenced ASTM standards, visit the ASTM website, www.astm.org, or contact ASTM Customer Service at service@astm.org. For *Annual Book of ASTM Standards* volume information, refer to the standard's Document Summary page on the ASTM website.

- C 1458 [Test Method for Nondestructive Assay of Plutonium, Tritium and²⁴¹Am by Calorimetric Assay](#)
- C 1490 [Guide for the Selection, Training and Qualification of Nondestructive Assay \(NDA\) Personnel](#)
- C 1493 [Test Method for Non-Destructive Assay of Nuclear Material in Waste by Passive and Active Neutron Counting Using a Differential Die-Away System](#)
- C 1500 [Test Method for Nondestructive Assay of Plutonium by Passive Neutron Multiplicity Counting](#)
- ~~C 1514 Test Method for Measurement of ²³⁵U Fraction Using the Enrichment Meter Principle~~ [U Fraction Using Enrichment Meter Principle](#)
- [C 1673 Terminology of C26.10 Nondestructive Assay Methods](#)

3. Terminology

3.1 Definitions presented here are confined to those terms not defined in common nuclear materials glossaries/references or whose use is specific to this application. The use of statistical terms is consistent with the definitions in American National Standard Statistical Terminology and Notation for Nuclear Materials Management, N15.5-1972. Some of those definitions are repeated here for convenience to the reader.

3.1 Definitions presented here are confined to those terms not defined in C 1673, other common nuclear materials glossaries/references or whose use is specific to this application.

3.2 Definitions:

3.2.1 *(α, n) reactions*—(α, n) reactions occur when energetic alpha particles collide with low atomic number nuclei, such as O, F, or Mg, producing single neutrons.

3.2.2 *²⁴⁰Pu effective mass— m_{eff}* is the mass of ²⁴⁰Pu that would produce the same coincident, or total, neutron response in the instrument as the assay item, all other factors remaining unchanged. It is correlated to the quantity of even mass isotopes of plutonium in the assay item. *differential die away technique (DDT), n* —also referred to as DDA, an NDA technique for characterizing the prompt neutrons from fissionable nuclides in scrap and waste using a neutron generator interrogation source.

3.2.2 *quality measurement practice, n* —an acceptable way to perform some operation associated with a specific measurement technique that is known or believed to influence the quality of a measurement (a way to perform some operation associated with a specific NDA technique in a manner that meets the quality requirements of a measurement).

3.2.3 *absorber foils*—thin metal foils that are used to reduce the contribution of low-energy gamma rays to the overall count rate. *in-process material, n* —the nuclear material in a process stream, excluding holdup.

3.2.4 *accidentals*—the accidental or random summing of neutrons generate a signature like that from true or Real coincidences. For shift register pulse train deconvolution the number of neutrons detected in the (A) gate period following the initial detection of each neutron during the selected count time t . This is a measured quantity. *passive neutron coincidence counting, n* —a technique used to measure the rate of coincident neutron emission in the assay item. The terminology refers specifically to shift-register electronics.

3.2.5 *accuracy*—(1) bias; (2) the closeness of a measured value to the true value; and (3) the closeness of a measured value to an accepted reference or standard value. *Poisson assumption, n* —for counting measurements, it is assumed that the net counts in a fixed period of time follow a Poisson distribution. This assumption can be verified by comparing the observed standard deviation of a series of measurements on an item with the square root of the average number of counts. If the Poisson assumption is correct, these numbers should be equal within random error.

3.2.6 *assay*—to determine quantitatively the amount of one or more nuclides of interest contained in an item, or the result of such a determination. *procedure, n* —a set of systematic instructions for using a method of measurement or of the steps associated with the method.

3.2.7 *background*—extraneous signal superimposed on the signal of interest. *qualitative analysis, n* —an analysis or measurement in which some or all of the components of an item are determined.

3.2.8 *benign matrix*—bulk material that has no effect on the result of the measured parameter. *radioactive emissions, n* —alpha, beta, gamma-ray, x-ray, heat, and neutron emissions from spontaneous fission, induced fission, or delayed neutron emission following beta decay.

3.2.9 *bias*—a constant positive or negative deviation of the method average from the correct value or accepted reference value. *replicate, n* —a counterpart of another measurement. It is the general case for which duplicate, consisting of two measurements, is the special case.

3.2.10 *calibration*—the determination of the values of the significant parameters by comparison with values indicated by a reference instrument, by a set of reference standards or modeled parameters. — **C859 segmented gamma scanner, n** —an NDA technique used to measure the gamma-ray emissions from low-density scrap and waste packaged in cylindrical containers. The technique involves independent measurements of the vertical segments of the container and may incorporate corrections for count rate losses and matrix attenuation.

3.2.11 *certification*—a written declaration from a certifying body or its legitimate designee that a particular measurement process complies with stated criteria, or a measured item has the stated characteristics.

3.2.12 *coincident neutrons*—two or more neutrons emitted simultaneously from a single event, such as from a nucleus during fission.

3.2.13 *collimator*—usually constructed of lead or tungsten, a collimator serves to define a gamma-ray detector's horizontal and

vertical viewing angles and to shield the detector from ambient radiation:

3.2.14 *confidence interval*—the range of values, calculated from an estimate of the mean and standard deviation, which is expected to include the population mean with a stated level of confidence.

3.2.15 *control chart*—a graphical plot of test results with respect to time or sequence of measurement together with limits in which they are expected to lie when the system is in a state of statistical control.

3.2.16 *control limits*—the limits shown on a control chart beyond which it is highly improbable that a point could lie while the system remains in a state of statistical control.

3.2.17 *corrections*—techniques that are part of the data analysis or method, which compensate for the effects of variables that interfere with the measurement and degrade accuracy. These corrections account for such things as matrix material, lumps, heterogeneity, dead time, and background.

3.2.18 *dead time*—the period following the detection of an event during which the system cannot register a subsequent event. Dead time is usually expressed as a percentage of elapsed time.

3.2.19 *differential die away technique (DDT)*—an NDA technique for characterizing the prompt neutrons from fissionable isotopes in scrap and waste using a neutron generator interrogation source.

3.2.20 *good measurement practice*—an acceptable way to perform some operation associated with a specific measurement technique that is known or believed to influence the quality of a measurement (a way to perform some operation associated with a specific NDA technique in a manner that meets the quality requirements of a measurement).

3.2.21 *holdup*—the amount of nuclear material remaining in process equipment and facilities after the in-process material, stored materials and product are removed.

3.2.22 *homogeneous matrix*—the degree to which the matrix materials are spread uniformly throughout the item container. Non homogeneous matrices are referred to as heterogeneous.

3.2.23 *in-process material*—the nuclear material in a process stream, excluding holdup.

3.2.24 *item*—nuclear material in a container or other suitable configuration for assay.

3.2.25 *lower limit of detectability*—a stated limiting value which designates the lowest concentration, mass, or activity that can be detected with confidence and which is specific to a particular measurement. **C859, C1215**

3.2.26 *low level waste*—waste that is not defined as transuranic or high level waste. **DOE order 435.1**

3.2.27 *matrix*—the material, which comprises the bulk of the item, except for the special nuclear material and the container. This is the material in which the special nuclear material is embedded.

3.2.28 *matrix-specific calibration*—uses a calibration matrix similar to the matrix to be measured. No matrix correction factors are used. This calibration is generally not appropriate for other matrices.

3.2.29 *modeling*—the use of mathematical techniques to simulate a measurement process or alternatively the process of creating a physical mock up of a measurement.

3.2.30 *neutron absorbers*—materials which have relatively large thermal-neutron absorption cross sections. Absorbers with the largest cross sections are commonly known as neutron poisons. Some examples are lithium, boron, cadmium, and gadolinium.

3.2.31 *neutron moderators*—materials which slow down neutrons through elastic scattering or inelastic interactions. Materials containing large amounts of low atomic weight materials, for example, hydrogen are highly moderating.

3.2.32 *neutron multiplication*—multiplication takes place when a neutron interaction yields more than one neutron as a product. Induced fission is the primary mechanism for neutron multiplication, however ($n, 2n$) interactions are also multiplication events.

3.2.33 *nondestructive assay (NDA)*—the observation of spontaneous or stimulated nuclear radiations, interpreted to estimate the content of one or more nuclides of interest in the item assayed, without affecting the physical or chemical form of the material.

3.2.33.1 *active assay*—assay based on the observation of radiation(s) induced by irradiation from an external source.

3.2.33.2 *passive assay*—assay based on the observation of naturally occurring or spontaneous nuclear radiation(s).

3.2.34 *nuclide*—an atomic species characterized by the composition of its nucleus, that is, by the number of protons and neutrons it contains.

3.2.35 *passive neutron coincidence counting*—a technique used to measure the rate of coincident neutron emission in the assay item. The terminology refers specifically to shift-register electronics.

3.2.36 *Poisson assumption*—for counting measurements, it is assumed that the net counts in a fixed period of time follow a Poisson distribution. This assumption can be verified by comparing the observed standard deviation of a series of measurements on an item with the square root of the average number of counts. If the Poisson assumption is correct, these numbers should be equal within random error.

3.2.37 *precision*—a generic concept used to describe the dispersion of a set of measured values. Measures frequently used to describe precision are standard deviation, relative standard deviation, variance, repeatability, reproducibility, confidence interval, and range. (See Guide C1215 for a more complete discussion of precision.)

3.2.38 *procedure*—a set of systematic instructions for using a method of measurement or of the steps associated with the method.

3.2.39 *qualitative analysis*—an analysis or measurement in which some or all of the components of an item are determined.

3.2.40 *radioactive emissions*—alpha, beta, gamma-ray, x-ray, heat, and neutron emissions from spontaneous fission, induced fission, or delayed neutron emission following beta decay.

3.2.41 *radioactive scrap*—materials that contain sufficient quantities of source or special nuclear material to be worthy of

- recovery. **C859**
- 3.2.42 *radioactive waste*—items containing radioactive materials not currently considered useful or economically recoverable. **C859**
- 3.2.43 *random error*—the chance variation encountered in all measurement work, characterized by the random occurrence of deviations from the mean value. **C1215**
- 3.2.44 *rate loss correction*—a correction for count rate related losses that are used for some gamma-ray NDA techniques. The correction may use radioactive sources with gamma-ray energies lower than the gamma ray from the nuclide of interest or a pulser.
- 3.2.45 *reals*—this quantity is the difference between the $(R+A)$ and (A) quantities.
- 3.2.46 *reals plus accidentals*—the number of events detected in the $(R+A)$ gate period following the initial detection of each neutron associated with neutron counting. This is a measured quantity during the count time.
- 3.2.47 *repeatability*—the within group dispersion of several groups of measurements. **C1215**
- 3.2.48 *replicate*—a counterpart of another measurement. It is the general case for which duplicate, consisting of two measurements, is the special case.
- 3.2.49 *reproducibility*—the between group dispersion of several groups of measurements. **C1215**
- 3.2.50 *sample*—a portion of a population or lot. In the context of NDA measurements, it may consist of measurements of items that are part of a larger group that could have been considered.
- 3.2.51 *secular equilibrium*—the state of equilibrium that exists when series of radioisotopes have equal and constant activity levels. Secular equilibrium should be established when the half life of the parent is much greater than that of the decay products.
- 3.2.52 *segmented gamma scanner*—a nondestructive assay technique used to measure the gamma-ray emissions from low-density scrap and waste packaged in cylindrical containers. The technique involves independent measurements of the vertical segments of the container and may incorporate corrections for count rate losses and matrix attenuation.
- 3.2.53 *self-attenuation*—the attenuation of emitted radiation by the emitting material itself.
- 3.2.54 *sensitivity*—the capability of methodology or instrumentation to discriminate between items having differing concentrations or containing differing amounts of a radioactive material.
- 3.2.55 *shift-register-based coincidence circuit*, *n*—an electronic circuit for determining totals T , Reals plus Accidentals $(R+A)$, and accidentals (A) in a selected count time (t) during neutron counting.
- 3.2.56 *3.2.12 shuffler, n*—an NDA technique for characterizing the delayed neutrons from fissionable isotopes/nuclides in scrap and waste using a ^{252}Cf interrogation source.
- 3.2.57 *special nuclear material (SNM)*—Plutonium, ^{233}U , uranium enriched in ^{233}U or ^{235}U to greater than its natural abundance; and any other materials defined as SNM under the U.S. Atomic Energy Act of 1954, as amended. This term does not include source materials. **C859**
- 3.2.58
- 3.2.13 *standard:*
- 3.2.58.1 *calibration standard*
- 3.2.13.1 *calibration standard, n*—an item sometimes physically and chemically similar to the items to be assayed, for which the mass of the nuclide(s) of interest and all properties to which the measurement technique is sensitive are known.
- 3.2.58.2 *working standard*
- 3.2.13.2 *working standard, n*—an item used to check the performance of an NDA instrument, nominally representative of the items to be assayed, and fabricated and handled to ensure its internal integrity so that deviations in its measured response can be attributed to the instrument.
- 3.2.59 *total measurement uncertainty (TMU)*—an estimated parameter, either mass, activity, concentration, or fractional, used to quantify the overall confidence in the assay result at a prescribed level including all sources of precision and bias. The TMU is qualified by the assumptions of the error propagation model.
- 3.2.60 *totals*—the total number of neutrons detected during the count time. This is a measured quantity.
- 3.2.61 *traceability*—the property determined by a measurement which can be related to appropriate standards, generally national or international standards, through an unbroken chain of comparisons.
- 3.2.62 *transmission source*—a radioactive source external to the item being measured that is used to determine the attenuation of gamma rays of interest by the matrix material in the item.
- 3.2.63 *transuranic waste (TRU waste)*—as defined in DOE Order 5820.2 and DOE Order 435.1, transuranic waste is radioactive waste containing alpha-emitting isotopes with atomic number greater than 92 and half-life greater than 20 years, and with activity concentrations greater than 3.7×10^6 Bq per kg (100 nCi per gram) of waste at the time of the measurement.
- 3.2.64 *uncertainty*—a generic term describing the inability of a measurement process to determine the correct value. (Alternate definition: Parameters associated with the result of a measurement that characterizes the dispersion of values that could reasonably be attributed to the measurement.)
- 3.2.65 *validation*—an evaluation that shows the quality assurance and quality control mechanisms are in place and functioning properly to ensure that the waste characterization information is collected and analyzed in a manner described by procedures and meets assigned data quality objectives.
- 3.2.66 *verification*

~~3.2.14~~ *verification, n*—an evaluation of the critical item characteristics to ensure the collected characterization data represents the true characteristics of the sample population to an acceptable degree of accuracy and precision.

~~3.2.67~~ *waste acceptance criteria (WAC)*—the set of requirements pertaining to a waste item that must be satisfied before it can be shipped to a designated facility for disposal.

4. Significance and Use

~~4.1~~ **4.1** *Good NDA* **4.1** *NDA measurement practices aimed at achieving quality results* are described in this guide. The application of the material provided in this guide should be determined on a case by case basis. Not all elements are required for all applications.

4.2 Nondestructive assay measurements are typically performed when the items measured or goals of the measurement program favor NDA over destructive analysis. NDA is typically favored when collecting a representative sample of the item is difficult or impractical (for example, scrap and waste items), personnel exposure would be significant, spread of contamination from sampling would occur, generation of secondary waste must be minimized, the weight and/or tare weight of the item cannot easily be determined (for example, in place process equipment), rapid turn around of the measurement results is needed, or the NDA measurement is significantly less expensive than the equivalent destructive analysis.

4.3 The principles provided in this guide should be used to determine which type of measurement is best suited to the measurement application. This determination involves consideration of the characteristics of the items to be measured, as well as the goals of the measurement program.

4.4 This guide applies to the suite of NDA instruments and measurement methods, many of which are described in detail in Refs (1) and (2).³ A partial listing of measurement methods and applicable use references is provided in 5.6.1. It is incumbent upon the user to seek additional guidance within ASTM method-specific standards, as this guide does not take precedence. Additional information on specific methods is best found in technical meeting transactions, journals, commercial application notes, and NRC/DOE publications.

4.5 This guide may be applied to many situations spanning the range of nuclear materials from product through waste. Typical applications include: the measurement and characterization of transuranic wastes, low-level wastes, and mixed wastes; the determination of radioactivity below some regulatory threshold, estimated for non-detected radionuclides; the measurement of safeguarded nuclear materials; shipper receiver confirmation; confirmation of nuclear material inventory; support of nuclear criticality safety evaluations; measurement of holdup of special nuclear material in process systems; support of decontamination and decommissioning activities; and in-situ analyses of facilities, glove-boxes, hot cells, and the environment prior to and following demolition.

4.6 When applied to measurement of waste, this guide should be used in conjunction with a waste management plan that segregates the contents of assay items into material categories according to some or all of the following criteria: bulk density of the waste, chemical forms of the radioactive constituents and matrix, (α , n) neutron intensity, hydrogen (moderator) and absorber content, thickness of fissile mass(es), and the assay item container size and composition. Each matrix may require a different set of calibration standards and may have different mass calibration limits. The effect on the quality of the assay (that is, ~~minimizing~~maximizing precision and minimizing bias) can significantly depend on the degree of adherence to this waste management plan.

4.7 This guide addresses elements of ~~good~~quality measurement practice such as; nuclear measurement instrumentation and its care; common hazards; facility readiness and requirements to support the NDA equipment; project scoping, requirements and objectives; assembly and deployment of the instrument; calibration and test; computational modeling to augment physical testing; measurement validation; preventive maintenance; and the measurement control program.

5. ~~Good Practice~~ Quality Measurement Practice

5.1 *Introduction*—NDA measurements of nuclear material are performed to determine the relative or absolute abundance of one or more nuclides. Typically, such a determination is made by comparing the observed response of an unknown amount of material to the response of one or more known standards by means of a functional relationship established by calibration. NDA refers to the qualification and quantification of radionuclides using instrumentation capable of detecting a feature of the radioactive-decay process. These features include such radioactive emissions as alpha, beta, gamma-ray, x-ray, heat, and neutron emissions from spontaneous fission, induced fission, or delayed neutron emission following beta decay.

5.2 The primary goal of NDA measurements is to arrive at a quality result, that is, one that satisfies the user's measurement needs. Adequately analyzing problems and applying appropriate measurement techniques support this goal.

5.3 Each NDA technique has advantages and limitations that must be judged against the specific requirements of the intended applications. No single technique can satisfy all requirements. It is the responsibility of the user to consider the potential problems, and select the proper balance of measurement capability and desired precision and accuracy for the specific application.

5.4 The observed response of an NDA system shows sensitivity to a wide variety of factors that can bias the assay result. By careful selection of the measurement technique, attention to potential sources of error, implementation of operational procedures

³ The boldface numbers in parentheses refer to the list of references at the end of this standard.

to control item categorization and packaging, operator training and instrument maintenance, supplemental measurements and calculations, and proper organization and evaluation of test data, the quality of assay results can be optimized.

5.5 Because performance requirements for NDA systems are application dependent, only general guidance for the selection of a system can be provided. If more than one technique can satisfy the specific measurement requirements, other considerations such as economics, ease of operation, and availability of instrumentation will ordinarily determine the choice of a system. The following parameters are among those that should be considered when selecting NDA measurement systems:

- (a) The radionuclides to be measured, including the expected range of assays and interferences that may arise between radionuclides,
- (b) The physical form (particle size, particle density, radioactive material distribution, etc.),
- (c) The matrix (for example, pure product, oily waste, dry waste, degree of heterogeneity, average density, etc.),
- (d) The container and packing material (for example, size, wall thickness, mass, wall material),
- (e) Environmental conditions,
- (f) Measurement quality objectives,
- (g) The degree to which parameters affecting measurement results are known,
- (h) Location(s) at which measurements are needed,
- (i) Costs (instrument, set up, personnel, and operating costs),
- (j) Availability of instrumentation,
- (k) System maintenance requirements (reliability, stability, ruggedness, etc.),
- (l) Training requirements,
- (m) Ease of operation,
- (n) Program schedule, and Program schedule,
- (o) Surface dose rate, and
- (p) Item throughput.

5.6 NDA methods are often nuclide sensitive rather than element sensitive. Frequently the reaction of interest is possible in more than one species of nucleus present. Determination of the elemental content of an item from a measurement of radiations emitted by isotope(s) nuclide(s) of the elemental species and, in some cases, by their decay products requires knowledge of the relative radionuclide composition of the item assayed.

5.6.1 Many of the approaches to specific NDA measurement techniques are described by ASTM Standards as shown in Fig. 1. A listing of applicable ASTM and ANSI standards is provided in Section 7, Test Methods. Other standards may also be considered.

5.6.2 *Neutron Measurement Techniques*— Neutron techniques are based on the detection of neutrons, which are emitted with various energies. Neutron energies are generally not measured. A passive neutron measurement is made when the neutrons measured are a result of spontaneous fission, self induced fission, or (α, n) reaction. Passive neutron assay systems are usually more effective for plutonium than for uranium, although applications for both exist. An active measurement is performed when the measured neutrons are the result of induced fission. The quantity of a particular isotope nuclide may be obtained by measuring unusually low or high emission rates, distinctive time distributions, or markedly different energy spectra. To establish the quantity of radionuclide of interest from the directly observable neutron assay result(s) relative isotopic information is necessary. ~~Correction or allowances may be needed for:~~ Important considerations include:

- (a) ~~(α, n) contaminants,~~ interferences,
- (b) Hydrogen content,
- (c) Neutron moderation and absorption (poisons),
- (d) Container wall effects,
- (e) ~~Influence of uranium on plutonium assay,~~ Influence of uranium on plutonium assay or of plutonium on uranium assay,
- (f) Source self-shielding,
- (g) Non-uniformity in source/matrix distribution as it relates to neutron moderation and absorption,

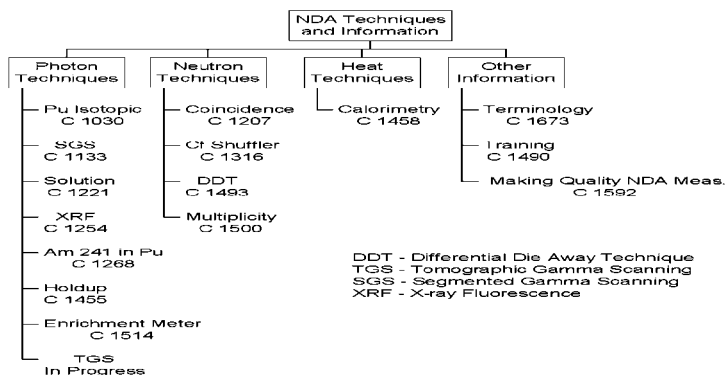

FIG. 1 NDA Techniques