

---

---

**Plain bearings — Wrapped bushes —  
Part 2:  
Test data for outside and inside  
diameters**

*Paliers lisses — Bagues roulées —*

*Partie 2: Données d'essai pour le diamètre extérieur et le diamètre  
intérieur*

**iTeh STANDARD PREVIEW  
(standards.iteh.ai)**

ISO 3547-2:2017

<https://standards.iteh.ai/catalog/standards/sist/72eec61d-8764-4b19-8c2c-2662ee59e697/iso-3547-2-2017>



**iTeh STANDARD PREVIEW**  
**(standards.iteh.ai)**

[ISO 3547-2:2017](https://standards.iteh.ai/catalog/standards/sist/72eec61d-8764-4b19-8c2c-2662ee59e697/iso-3547-2-2017)

<https://standards.iteh.ai/catalog/standards/sist/72eec61d-8764-4b19-8c2c-2662ee59e697/iso-3547-2-2017>



**COPYRIGHT PROTECTED DOCUMENT**

© ISO 2017, Published in Switzerland

All rights reserved. Unless otherwise specified, no part of this publication may be reproduced or utilized otherwise in any form or by any means, electronic or mechanical, including photocopying, or posting on the internet or an intranet, without prior written permission. Permission can be requested from either ISO at the address below or ISO's member body in the country of the requester.

ISO copyright office  
Ch. de Blandonnet 8 • CP 401  
CH-1214 Vernier, Geneva, Switzerland  
Tel. +41 22 749 01 11  
Fax +41 22 749 09 47  
[copyright@iso.org](mailto:copyright@iso.org)  
[www.iso.org](http://www.iso.org)

# Contents

	Page
Foreword .....	iv
<b>1 Scope</b> .....	<b>1</b>
<b>2 Normative references</b> .....	<b>1</b>
<b>3 Terms and definitions</b> .....	<b>1</b>
<b>4 Symbols and units</b> .....	<b>2</b>
<b>5 Presentation of data on drawing</b> .....	<b>2</b>
<b>6 Tests</b> .....	<b>4</b>
6.1 Test A .....	4
6.2 Test B .....	4
6.3 Test C .....	4
6.4 Test D .....	4
<b>7 Test A</b> .....	<b>4</b>
7.1 Description .....	4
7.2 Calculation basis .....	4
7.2.1 Elastic reduction, $v$ , of outside diameter, $D_o$ .....	4
7.2.2 Calculation of diameter of checking block, $d_{ch,1}$ .....	5
7.2.3 Effective cross-sectional area, $A_{cal}$ .....	5
7.2.4 Calculation of checking load, $F_{ch}$ .....	6
7.2.5 Limits for $\Delta z$ .....	7
7.3 Obtaining data — Example .....	7
7.4 Presentation of data on drawing — Example .....	8
<b>8 Test B</b> .....	<b>8</b>
8.1 Description .....	8
8.2 Obtaining data — Example .....	9
8.3 Presentation of data on drawing — Example .....	9
<b>9 Test C</b> .....	<b>9</b>
9.1 Description .....	9
9.2 Obtaining data — Example .....	10
9.3 Presentation of data on drawing — Example .....	10
<b>10 Test D</b> .....	<b>11</b>
10.1 Description .....	11
10.2 Obtaining data — Example .....	11
10.3 Presentation of data on drawing — Example .....	11
<b>11 Designation of tests according to this document</b> .....	<b>12</b>
<b>Bibliography</b> .....	<b>13</b>

## Foreword

ISO (the International Organization for Standardization) is a worldwide federation of national standards bodies (ISO member bodies). The work of preparing International Standards is normally carried out through ISO technical committees. Each member body interested in a subject for which a technical committee has been established has the right to be represented on that committee. International organizations, governmental and non-governmental, in liaison with ISO, also take part in the work. ISO collaborates closely with the International Electrotechnical Commission (IEC) on all matters of electrotechnical standardization.

The procedures used to develop this document and those intended for its further maintenance are described in the ISO/IEC Directives, Part 1. In particular the different approval criteria needed for the different types of ISO documents should be noted. This document was drafted in accordance with the editorial rules of the ISO/IEC Directives, Part 2 (see [www.iso.org/directives](http://www.iso.org/directives)).

Attention is drawn to the possibility that some of the elements of this document may be the subject of patent rights. ISO shall not be held responsible for identifying any or all such patent rights. Details of any patent rights identified during the development of the document will be in the Introduction and/or on the ISO list of patent declarations received (see [www.iso.org/patents](http://www.iso.org/patents)).

Any trade name used in this document is information given for the convenience of users and does not constitute an endorsement.

For an explanation on the meaning of ISO specific terms and expressions related to conformity assessment, as well as information about ISO's adherence to the World Trade Organization (WTO) principles in the Technical Barriers to Trade (TBT) see the following URL: [www.iso.org/iso/foreword.html](http://www.iso.org/iso/foreword.html).

This document was prepared by Technical Committee ISO/TC 123, *Plain bearings*, Subcommittee SC 3, *Dimensions, tolerances and construction details*.

This third edition cancels and replaces the second edition (ISO 3547-2:2006), which has been technically revised.

A list of all the parts in the ISO 3547 series can be found on the ISO website.

# Plain bearings — Wrapped bushes —

## Part 2: Test data for outside and inside diameters

### 1 Scope

This document specifies the test data for outside and inside diameters of wrapped bushes made of mono and multi-layer bearing material for plain bearing applications. It also specifies test designations.

Since the wall thickness of the bush is measured in the free condition, no special test data are required for this on the drawing (see ISO 3547-5 and ISO 3547-6).

**NOTE** Depending on the manufacturing method, the back of the bushes can show isolated light depressions and, similarly, bushes with lubrication holes, grooves and bore indentations can show distortion. It is therefore suggested to measure the wall thickness away from these areas.

### 2 Normative references

The following documents are referred to in the text in such a way that some or all of their content constitutes requirements of this document. For dated references, only the edition cited applies. For undated references, the latest edition of the referenced document (including any amendments) applies.

ISO 286-2, *Geometrical product specifications (GPS) — ISO code system for tolerances on linear sizes — Part 2: Tables of standard tolerance classes and limit deviations for holes and shafts*

ISO 3547-1:—<sup>1)</sup>, *Plain bearings — Wrapped bushes — Part 1: Dimensions*

ISO 3547-4, *Plain bearings — Wrapped bushes — Part 4: Materials*

ISO 3547-5, *Plain bearings — Wrapped bushes — Part 5: Checking the outside diameter*

ISO 4378-1, *Plain bearings — Terms, definitions, classification and symbols — Part 1: Design, bearing materials and their properties*

ISO 4378-4, *Plain bearings — Terms, definitions, classification and symbols — Part 4: Basic symbols*

ISO 12301, *Plain bearings — Quality control techniques and inspection of geometrical and material quality characteristics*

ISO 13715, *Technical drawings — Edges of undefined shape — Vocabulary and indication*

### 3 Terms and definitions

For the purposes of this document, the terms and definitions given in ISO 4378-1 and ISO 4378-4 apply.

ISO and IEC maintain terminological databases for use in standardization at the following addresses:

- ISO Online browsing platform: available at <http://www.iso.org/obp>
- IEC Electropedia: available at <http://www.electropedia.org/>

1) Under preparation. Stage at the time of publication: ISO/DIS 3547-1:2016.

## 4 Symbols and units

See [Table 1](#).

**Table 1 — Symbols and units**

Symbol	Description	Unit
$A_{cal}$	Reduced area of cross section (calculated value) of the bush	mm <sup>2</sup>
$B$	Width of the bush	mm
$C_i$	Inside chamfer	mm
$C_o$	Outside chamfer	mm
$D_{fl}$	Flange diameter	mm
$D_H$	Housing bore diameter	mm
$D_i$	Inside diameter of the bush	mm
$D_{i, ch}$	Inside diameter of the bush in the ring gauge	mm
$D_o$	Outside diameter of the bush	mm
$F_{ch}$	Checking load	mm
$d_{ch, 1}$	Diameter of the checking block or ring gauge	mm
$d_{ch, 2}$	Diameter of the setting plug or plug gauge	mm
$r$	Flange radius	mm
$s_1$	Thickness of the backing layer <sup>a</sup>	mm
$s_2$	Thickness of the bearing material layer <sup>a</sup>	mm
$s_3$	Wall thickness <sup>a</sup>	mm
$s_{fl}$	Flange thickness	mm
$\Delta D_o$	Tolerance of $D_o$	mm
$v$	Elastic reduction of the outside diameter under checking load $F_{ch}$	mm
$z$	Distance apart of the halves of the checking block	mm
$\Delta z$	Indicator reading	mm
$\Delta z_D$	Circumference indicator reading for test D	mm

<sup>a</sup> For bushes which are made of a single material,  $s_1 = s_3$  or  $s_2 = s_3$ .

## 5 Presentation of data on drawing

The drawing should show either

- the outside diameter,  $D_o$ , and the wall thickness,  $s_3$ , or
- the outside diameter,  $D_o$ , and the inside diameter,  $D_i$ .

Wall thickness,  $s_3$ , and inside diameter,  $D_i$ , shall not be specified together on the same drawing. See [Figure 1](#).

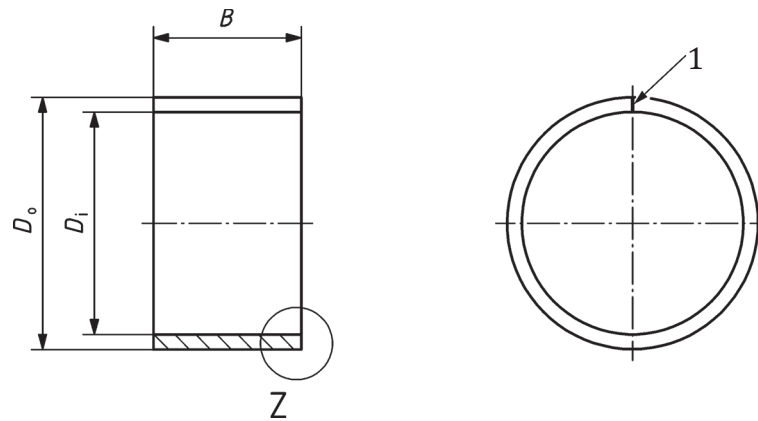

a) Type C cylindrical bush

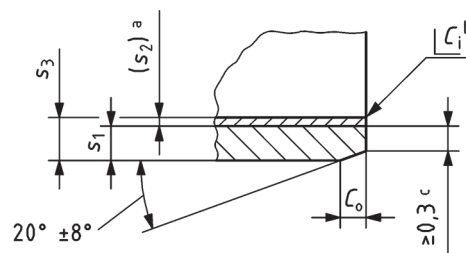
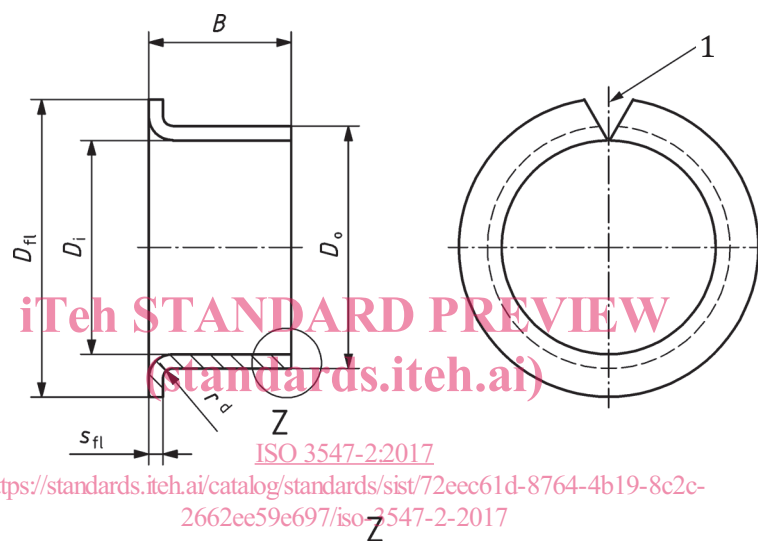

b) Type F flanged bush

**Key**

- 1 butt joint
- a Thickness of the bearing material layer: only valid as a basis for calculation in accordance with 7.2.
- b  $C_i$  may be a chamfer or break edge, in accordance with ISO 13715.
- c 0,2 mm min. for nominal wall thickness 0,5 mm.
- d  $r_{max} = s_3$

**Figure 1 — Cylindrical and flanged bush taken from ISO 3547-1**

## 6 Tests

### 6.1 Test A

Check the outside diameter,  $D_o$ , using a checking block in a test rig and setting plug, in accordance with [Clause 7](#).

### 6.2 Test B

Check the outside diameter,  $D_o$ , using two ring gauges, in accordance with [Clause 8](#).

### 6.3 Test C

Check the inside diameter,  $D_i$ , of a bush pressed into a ring gauge, in accordance with [Clause 9](#).

### 6.4 Test D

Check the outside diameter,  $D_o$ , using precision measuring tape, in accordance with [Clause 10](#).

## 7 Test A

### 7.1 Description

This test is applicable to  $D_o$  up to 180 mm.

The test rig consists of a base on which the two parts of the checking block are mounted (see ISO 3547-5).

A setting plug is inserted in the checking block and the two halves of the checking block are pressed towards one another using the given checking load,  $F_{ch}$ , and the indicator reading set.

The setting plug is then removed and replaced by the bush to be checked, and the checking load reapplied.

After the bush has been inserted, the distance,  $z$ , between the two halves of the checking block changes under checking load  $F_{ch}$  and the distance indicator reading,  $\Delta z$ , is recorded.

From this,  $D_o$  can be calculated.

Flanged bushes may be checked either before or after flange forming at the option of the manufacturer.

### 7.2 Calculation basis

#### 7.2.1 Elastic reduction, $v$ , of outside diameter, $D_o$

The elastic reduction,  $v$ , of the outside diameter,  $D_o$ , is the difference between  $D_o$  under zero load and the resultant diameter when the checking load,  $F_{ch}$ , is applied. Force  $F_{ch}$  shall be sufficient to ensure that the bush conforms properly to the surface of the test housing and that the results in the elastic reduction,  $v$ , of the outside diameter are in accordance with [Table 2](#).



**Table 2 — Elastic reduction,  $v$ , of the outside diameter,  $D_o$ , under checking load,  $F_{ch}$**

Dimensions in millimetres

$D_o$ nominal		$v$
	$\leq 6$	0,003
$> 6$	$\leq 12$	0,006
$> 12$	$\leq 80$	0,013
$> 80$	$\leq 180$	0,025

### 7.2.2 Calculation of diameter of checking block, $d_{ch,1}$

The diameter of the checking block can be calculated from the specified upper limit of the outside diameter,  $D_{o,max}$ , of the bush from [Formula \(1\)](#):

$$d_{ch,1} = D_{o,max} - v \quad (1)$$

### 7.2.3 Effective cross-sectional area, $A_{cal}$

In order to calculate the checking load,  $F_{ch}$ , the effective cross-sectional area,  $A_{cal}$ , of the bush shall first be determined.

$A_{cal}$  depends on the material type, bush width  $B$ ,  $s_1$  and  $s_2$ . See [Table 3](#).

**Table 3 — Nominal dimensions for wall thickness,  $s_3$ , backing material,  $s_1$ , and bearing layer,  $s_2$**

Dimensions in millimetres

Nominal thicknesses		
Wall thickness (see ISO 3547-1)	Backing material of bushes made from multi-layer materials	Bearing material layer of bushes made from multi-layer materials
$s_3$	$s_1$	$s_2$
0,5	0,3	0,2
0,75	0,53	0,22
1,0	0,68	0,32
1,5	1,1	0,4
2,0	1,55	0,45
2,5	2,05	0,45

The nominal size for  $B$ ,  $s_1$  and  $s_2$  shall then be substituted into the corresponding equation given in [Table 4](#).