

iTeh STANDARD PREVIEW
(standards.iteh.ai)

SIST ISO 3547-1:2020

<https://standards.iteh.ai/catalog/standards/sist/7d189d45-eb1d-4c4b-aae2-d824bc6038e1/sist-iso-3547-1-2020>

INTERNATIONAL
STANDARD

ISO
3547-1

Third edition
2018-07

**Plain bearings — Wrapped bushes —
Part 1:
Dimensions**

*Paliers lisses — Bagues roulées —
Partie 1: Dimensions*

**iTeh STANDARD PREVIEW
(standards.iteh.ai)**

[SIST ISO 3547-1:2020](https://standards.iteh.ai/catalog/standards/sist/7d189d45-eb1d-4c4b-aae2-d824bc6038e1/sist-iso-3547-1-2020)

<https://standards.iteh.ai/catalog/standards/sist/7d189d45-eb1d-4c4b-aae2-d824bc6038e1/sist-iso-3547-1-2020>



Reference number
ISO 3547-1:2018(E)

© ISO 2018

iTeh STANDARD PREVIEW (standards.iteh.ai)

SIST ISO 3547-1:2020

<https://standards.iteh.ai/catalog/standards/sist/7d189d45-eb1d-4c4b-aae2-d824bc6038e1/sist-iso-3547-1-2020>



COPYRIGHT PROTECTED DOCUMENT

© ISO 2018

All rights reserved. Unless otherwise specified, or required in the context of its implementation, no part of this publication may be reproduced or utilized otherwise in any form or by any means, electronic or mechanical, including photocopying, or posting on the internet or an intranet, without prior written permission. Permission can be requested from either ISO at the address below or ISO's member body in the country of the requester.

ISO copyright office
CP 401 • Ch. de Blandonnet 8
CH-1214 Vernier, Geneva
Phone: +41 22 749 01 11
Fax: +41 22 749 09 47
Email: copyright@iso.org
Website: www.iso.org

Published in Switzerland

Contents

	Page
Foreword	iv
1 Scope	1
2 Normative references	1
3 Terms and definitions	1
4 Symbols and units	1
5 Dimensions	2
6 Design	9
7 Example for calculation of inside diameter, D_i	10
8 Designation	10
Bibliography	11

iTeh STANDARD PREVIEW (standards.iteh.ai)

[SIST ISO 3547-1:2020](https://standards.iteh.ai/catalog/standards/sist/7d189d45-eb1d-4c4b-aae2-d824bc6038e1/sist-iso-3547-1-2020)

<https://standards.iteh.ai/catalog/standards/sist/7d189d45-eb1d-4c4b-aae2-d824bc6038e1/sist-iso-3547-1-2020>

ISO 3547-1:2018(E)

Foreword

ISO (the International Organization for Standardization) is a worldwide federation of national standards bodies (ISO member bodies). The work of preparing International Standards is normally carried out through ISO technical committees. Each member body interested in a subject for which a technical committee has been established has the right to be represented on that committee. International organizations, governmental and non-governmental, in liaison with ISO, also take part in the work. ISO collaborates closely with the International Electrotechnical Commission (IEC) on all matters of electrotechnical standardization.

The procedures used to develop this document and those intended for its further maintenance are described in the ISO/IEC Directives, Part 1. In particular the different approval criteria needed for the different types of ISO documents should be noted. This document was drafted in accordance with the editorial rules of the ISO/IEC Directives, Part 2 (see www.iso.org/directives).

Attention is drawn to the possibility that some of the elements of this document may be the subject of patent rights. ISO shall not be held responsible for identifying any or all such patent rights. Details of any patent rights identified during the development of the document will be in the Introduction and/or on the ISO list of patent declarations received (see www.iso.org/patents).

Any trade name used in this document is information given for the convenience of users and does not constitute an endorsement.

For an explanation on the voluntary nature of standards, the meaning of ISO specific terms and expressions related to conformity assessment, as well as information about ISO's adherence to the World Trade Organization (WTO) principles in the Technical Barriers to Trade (TBT) see the following URL: www.iso.org/iso/foreword.html. (standards.iteh.ai)

This document was prepared by Technical Committee ISO/TC 123, *Plain bearings*, Subcommittee SC 3, *Dimensions, tolerances and construction details*.
SIST ISO 3547-1:2020
<https://standards.iteh.ai/catalog/standards/sist/7d189d45-eb1d-4c4b-aae2-83dc6018e303/iso-3547-1-2018>

This third edition cancels and replaces the second edition (ISO 3547-1:2006), which has been technically revised. The main changes compared to the previous edition are as follows:

- Normative references have been updated.
- Formulae for the minimum and maximum inside diameters of the bush have been added.
- A formula for the expansion of the housing bore due to the pressing in of the bush has been added.

A list of all parts in the ISO 3547 series can be found on the ISO website.

Plain bearings — Wrapped bushes —

Part 1: Dimensions

1 Scope

This document specifies the dimensions and designations of cylindrical and flanged wrapped bushes made of mono and multi-layer bearing material for plain bearing applications.

2 Normative references

The following documents are referred to in the text in such a way that some or all of their content constitutes requirements of this document. For dated references, only the edition cited applies. For undated references, the latest edition of the referenced document (including any amendments) applies.

ISO 4378-1, *Plain bearings — Terms, definitions, classification and symbols — Part 1: Design, bearing materials and their properties*

ISO 4378-4, *Plain bearings — Terms, definitions, classification and symbols — Part 4: Basic symbols*

ISO 12301, *Plain bearings — Quality control techniques and inspection of geometrical and material quality characteristics*

SIST ISO 3547-1:2020

<https://standards.iteh.ai/catalog/standards/sist/7d189d45-eb1d-4c4b-aae2-d824bc6038e1/sist-iso-3547-1-2020>

3 Terms and definitions

For the purposes of this document, the terms and definitions given in ISO 4378-1 and ISO 4378-4 apply.

ISO and IEC maintain terminological databases for use in standardization at the following addresses:

- ISO Online browsing platform: available at <https://www.iso.org/obp>
- IEC Electropedia: available at <http://www.electropedia.org/>

4 Symbols and units

See [Table 1](#).

Table 1 — Symbols and units

Symbol	Description	Unit
B	Width of the bush	mm
C_i	Inside chamfer	mm
C_o	Outside chamfer	mm
D_i	Inside diameter of the bush	mm
$D_{i,min}$	Minimum inside diameter of the bush	mm
$D_{i,max}$	Maximum inside diameter of the bush	mm
$D_{i, ch}$	Inside diameter of the bush in the ring gauge	mm
D_{fl}	Flange diameter	mm
^a	For bushes which are made of a single material, $s_1 = s_3$ or $s_2 = s_3$.	

Table 1 (continued)

Symbol	Description	Unit
D_H	Housing bore diameter	mm
$D_{H,min}$	Minimum housing bore diameter	mm
$D_{H,max}$	Maximum housing bore diameter	mm
D_o	Outside diameter of the bush	mm
$D_{o,m}$	Mean diameter of the bush	mm
$D_{H,m}$	Mean housing bore diameter	mm
D_S	Shaft diameter	mm
$d_{ch,1}$	Diameter of the checking block or ring gauge	mm
E	Expansion of the housing bore	mm
Ra	Surface roughness	μm
r	Flange radius	mm
s_1	Thickness of the bearing backing ^a	mm
s_2	Thickness of the bearing material layer ^a	mm
s_3	Wall thickness ^a	mm
$s_{3,min}$	Minimum wall thickness	mm
$s_{3,max}$	Maximum wall thickness	mm
s_{fl}	Flange thickness	mm

^a For bushes which are made of a single material, $s_1 = s_3$ or $s_2 = s_3$.

5 Dimensions

See [Figure 1](#) and [Tables 2](#) to [4](#).

$$D_{i,max} = D_{H,max} - 2 \cdot s_{3,min} \quad (1)$$

$$D_{i,min} = D_{H,min} - 2 \cdot s_{3,max} \quad (2)$$

This assumes that there is no expansion of the bore in the housing caused by pressing in the bush. In reality, the expansion depends on several factors, such as the stiffness of the housing and the bush. An example of the calculation is given in [Clause 7](#).

The wall thickness tolerance depends on whether or not there is a machining allowance in the bush bore and on the material type, as specified in ISO 3547-4. The preferred tolerance series (A to E) is specified in [Table 5](#).

Instead of the wall thickness, the inside diameter, $D_{i, ch}$, of the bush may be specified. $D_{i, ch}$ is the inside diameter of the bush, when this is pressed into a ring gauge (Test C — gauging — in accordance with ISO 3547-2; see also ISO 3547-6).

For bushes which are supplied with a machined bore (Series W), the tolerances of the inside diameter of the bush, $D_{i, ch}$, checked in a ring gauge, are given in [Table 6](#).

In no case shall wall thickness and inside diameter be given at the same time as the dimensions that are to be checked.

The tolerance for the inside diameter, $D_{i, ch}$, of the bush in the ring gauge is given in [Table 6](#). The tolerance of the inside diameter of a bush pressed into a housing is found from the sum of the tolerance for, $D_{i, ch}$, and the tolerance of the housing bore. As in the case of the calculation of the inside diameter from the wall thickness, it is assumed that there is no expansion of the housing bore.

Dimensions for the outside diameter, D_o , of the bush are given in [Table 7](#).

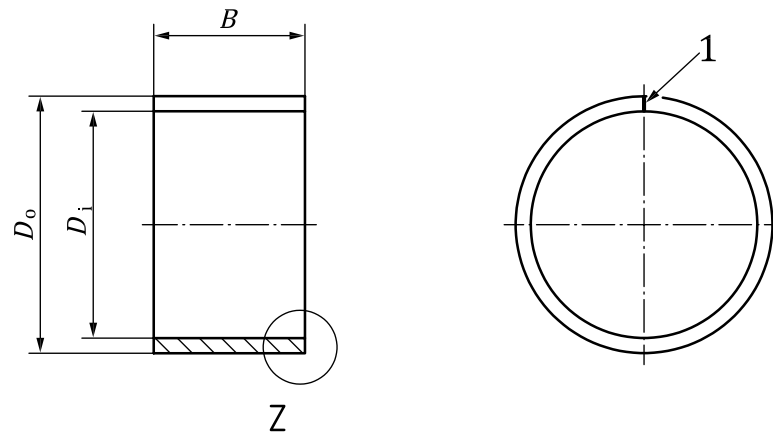

a) Type C cylindrical bush

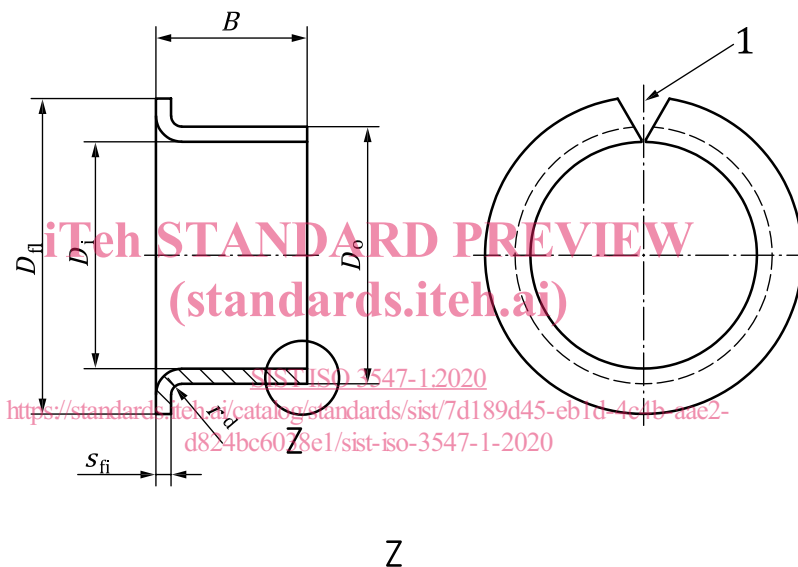

b) Type F flanged bush

Key

- 1 butt joint
- a Thickness of the bearing material layer: only valid as a basis for calculation in accordance with ISO 3547-2.
- b C_i may be a chamfer or break edge, in accordance with ISO 13715.
- c 0,2 mm min. for nominal wall thickness 0,5 mm.
- d $r_{\max} = s_3$.

Figure 1 — Cylindrical and flanged bush