International Standard



2236

INTERNATIONAL ORGANIZATION FOR STANDARDIZATION • МЕЖДУНАРОДНАЯ ОРГАНИЗАЦИЯ ПО СТАНДАРТИЗАЦИИ • ORGANISATION INTERNATIONALE DE NORMALISATION

Assembly tools for screws and nuts — Forged and tubular socket wrenches — Maximum outside head dimensions

Outils de manœuvre pour vis et écrous — Clés à béquille et à pipe forgées et clés en tube — Dimensions extérieures maximales des têtes

Second edition — 1982-12-01

ITeH STANDARD PREVIEW
(standards.iteh.ai)

[ISO 2236:1982](https://standards.iteh.ai/catalog/standards/sist/bbbdeecac-1d3c-4f28-9c68-77837d4b083a/iso-2236-1982)

<https://standards.iteh.ai/catalog/standards/sist/bbbdeecac-1d3c-4f28-9c68-77837d4b083a/iso-2236-1982>

UDC 621.883.14

Ref. No. ISO 2236-1982 (E)

Descriptors : tools, assembly tools, wrenches, socket wrenches, dimensions.

Assembly tools for screws and nuts — Forged and tubular socket wrenches — Maximum outside head dimensions

1 Scope and field of application

This International Standard lays down maximum outside dimensions for forged and tubular socket wrench heads, metric series.

2 Reference

ISO 272, *Fasteners — Hexagon products — Widths across flats.*

3 Maximum outside head dimensions

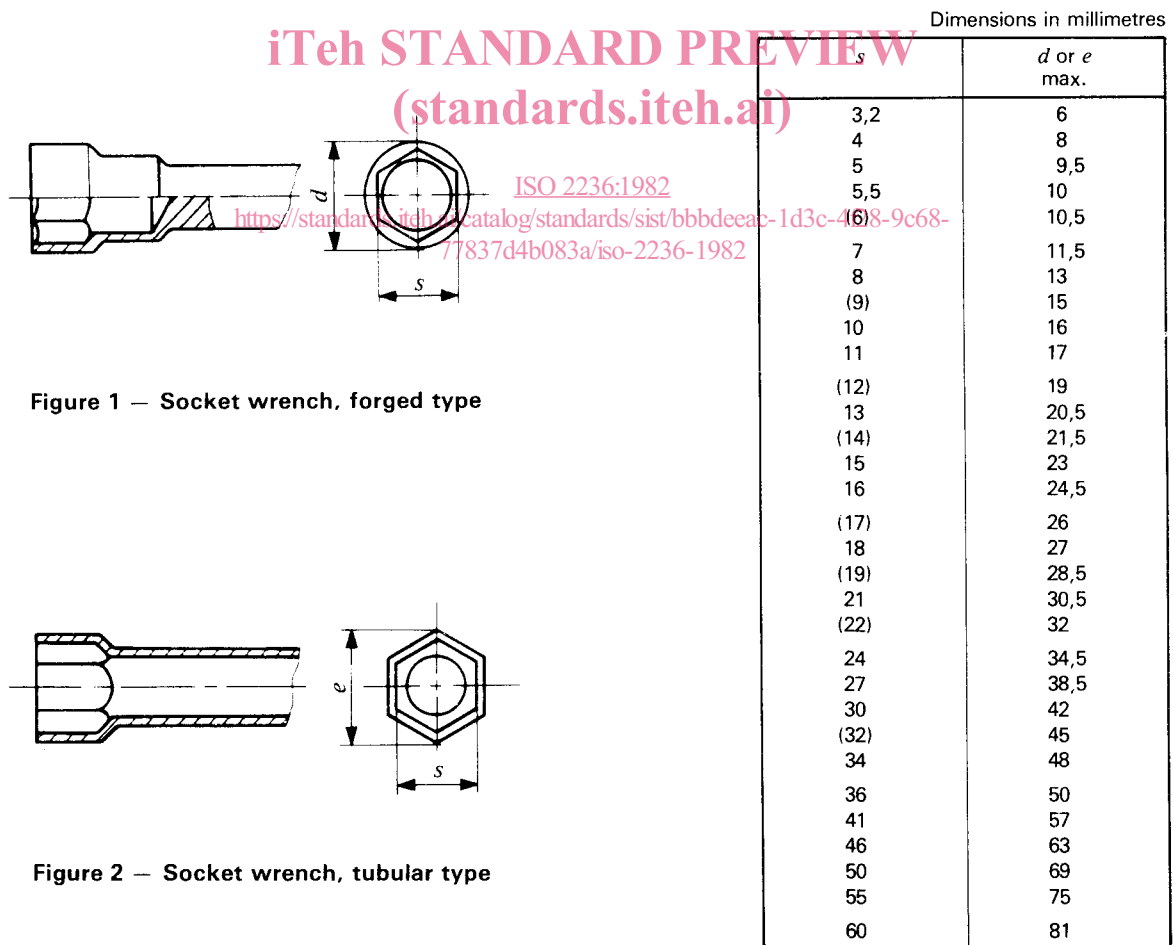

Figure 1 — Socket wrench, forged type

Figure 2 — Socket wrench, tubular type

Values in brackets are not standardized across-flats in ISO 272, but are maintained temporarily in this International Standard.