



Designation: E 127 – 98

Standard Practice for Fabricating and Checking Aluminum Alloy Ultrasonic Standard Reference Blocks¹

This standard is issued under the fixed designation E 127; the number immediately following the designation indicates the year of original adoption or, in the case of revision, the year of last revision. A number in parentheses indicates the year of last reapproval. A superscript epsilon (ϵ) indicates an editorial change since the last revision or reapproval.

This specification has been approved for use by agencies of the Department of Defense.

1. Scope

1.1 This practice covers a procedure for fabricating aluminum alloy ultrasonic standard reference blocks that can be used for checking performance of ultrasonic testing equipment and for standardization and control of ultrasonic tests of aluminum alloy products using pulsed longitudinal waves introduced into test material either by the direct-contact method or by the immersion method. A recommended procedure for checking blocks is described and calibration data for a number of reference blocks are tabulated. Statements concerning procedures are provided without a discussion of the technical background for the preference. The necessary technical background can be found in Refs. (1-14).²

NOTE 1—Practice E 428 and Guide E 1158 also describe procedures for selecting material, fabricating blocks, and checking response. Unlike this practice, there is no requirement for evaluation relative to a specified standard target.

1.2 *This standard does not purport to address all of the safety concerns, if any, associated with its use. It is the responsibility of the user of this standard to establish appropriate safety and health practices and determine the applicability of regulatory limitations prior to use.*

2. Referenced Documents

2.1 ASTM Standards:

- E 317 Practice for Evaluating Performance Characteristics of Ultrasonic Pulse-Echo Testing Systems Without the Use of Electronic Measurement Instruments³
- E 428 Practice for Fabrication and Control of Steel Reference Blocks Used in Ultrasonic Inspection³

¹ This practice is under the jurisdiction of ASTM Committee E-7 on Nondestructive Testing and is the direct responsibility of Subcommittee E07.06 on Ultrasonic Method.

Current edition approved Dec. 10, 1998. Published February 1999. Originally published as E 127 – 58 T. Last previous edition E 127 – 95.

² The boldface numbers in parentheses refer to the list of references at the end of this practice.

³ *Annual Book of ASTM Standards*, Vol 03.03.

E 1158 Guide for Material Selection and Fabrication of Reference Blocks for the Pulsed Longitudinal Wave Ultrasonic Examination of Metal and Metal Alloy Production Material³

E 1316 Terminology for Nondestructive Examinations³

E 1324 Guide for Measuring Some Electronic Characteristics of Ultrasonic Examination Instruments³

3. Terminology

3.1 *Definitions*—For definitions of terms not specific to this practice, refer to Terminology E 1316.

3.2 *Definitions of Terms Specific to This Standard:*

3.2.1 *angular error*—the condition observed in ultrasonic tests of reference blocks when the response from the hole bottom is not maximum while the search unit is positioned to obtain either a maximum number of back reflections from a reference block or a maximum indication from its entry surface. Angular error results when the entry surface, hole bottom, and back surface are not parallel to each other.

3.2.2 *area-amplitude response curve*—a curve showing the relationship between different areas of reflecting targets located at a constant distance in an ultrasonic transmitting medium and their respective amplitudes of ultrasonic response.

3.2.3 *back reflection*—the indication, observed on the display screen of a test instrument, that represents the ultrasonic energy reflected from the back surface of a reference block.

3.2.4 *back surface*—the end of a reference block that is opposite the entry surface.

3.2.5 *entry surface*—the end of a reference block through which ultrasonic energy must pass when reflections from the hole bottom are obtained.

3.2.6 *hole bottom*—the flat reflecting surface in a reference block that is obtained by making the entire end of a drilled hole smooth and flat using best machining practices. The hole bottom is parallel to the entry surface of the block.

3.2.7 *hole size*—the diameter of the hole in a reference block that determines the area of the hole bottom.

3.2.8 *metal distance*—the distance in a reference block from its entry surface to the hole bottom.

3.2.9 *reference block*—an aluminum block, containing as an artificial discontinuity a flat-bottom drilled hole of known size.

3.2.10 *ultrasonic response*—the height of the indication, observed on a display screen of a test instrument, that represents the amount of ultrasonic energy initially reflected from the hole bottom in a reference block. Units usually used in measuring height of indication are inches, trace-to-peak, or percent of upper linearity limit.

4. Summary of Practice

4.1 Aluminum alloy stock is ultrasonically evaluated to ensure freedom from significant discontinuities and is then precisely fabricated into cylindrical blocks of prescribed lengths. A single, flat-bottom hole of specific diameter is drilled to a constant depth into the end of each block at its center, and the blocks are grouped into sets according to hole size and block length, or metal distance.

4.2 Each block is checked ultrasonically using a calibrated ultrasonic test system at a prescribed test frequency. Distance-amplitude and area-amplitude characteristics are established for sets of fabricated blocks using specific reflectors to provide a standard response. Curves are plotted to establish the interrelationship between the various blocks in the sets.

4.3 To permit the use of instrumentation similar to that originally used in developing this practice, or types more recently manufactured, two alternative test system calibration procedures are described. The first method (ball-to-block) which utilizes steel balls as reference standards, is covered in 11.8.2. The second method (block-to-block), which requires as reference standards, blocks which have been calibrated by the National Institute of Standards and Technology (NIST), is described in Annex A1.⁴

5. Significance and Use

5.1 Reference blocks fabricated to this practice will exhibit specific area-amplitude and distance-amplitude relationships only with an immersion test at 5 MHz using the search unit, test instrument, and test parameters described in this practice. Comparison tests at other frequencies or with uncalibrated test systems will not necessarily give the same relationships shown in this practice.

NOTE 2—The 1964 and prior issues of this practice required a test frequency of 15 MHz. Blocks conforming to earlier issues of this practice may not produce ultrasonic responses that conform to this issue. See Section 13 regarding provision for recertification or correction curves and tables.

5.2 Although the primary ultrasonic evaluation of blocks is performed at a specified frequency, the blocks may be used to standardize ultrasonic tests at any frequency and with any

⁴ Measurement services to determine the ultrasonic response of reference blocks intended to meet the requirements of this practice are available from the National Institute of Standards and Technology (formerly NBS), Office of Measurement Services, Gaithersburg, MD 20899. Unless otherwise requested, the calibration procedure used by NIST is that based on Publication NIST IR 5430. This has small but significant differences from that in this practice; however the NIST data base indicates that the NIST procedure is in consonance with the requirements of the practice.

pulse-echo ultrasonic test system. Establishment of distance-amplitude and area-amplitude characteristics is necessary for each application.

6. Description of Various Recommended Sets

6.1 In ultrasonic testing of aluminum alloy products, a standard reference usually is necessary to establish a specified test sensitivity. A standard ultrasonic reference also is required frequently to determine the effect of variations in metal distance upon the ultrasonic response from detected discontinuities. Test sensitivity standardizations and corrections for metal distance are most reliable when made under the same conditions employed for the actual tests. For these purposes, aluminum alloy reference blocks containing various combinations of hole size and metal distance are necessary.

6.2 The following combinations or sets of blocks are recommended:

6.2.1 *Basic Set*—The basic set consisting of ten reference blocks is listed in Table 1. Area-amplitude relations are obtained by intercomparison of blocks containing the 3-in. (76.2-mm) metal distance and 3/64-in., 5/64-in., and 8/64-in. (Note 3) diameter holes, respectively. Distance-amplitude relations are obtained by intercomparison of the blocks of various lengths which contain 5/64-in. diameter holes.

NOTE 3—Direct conversion from inches to millimetres (1 in. = 25.4 mm) gives hole size dimensions for which there are no standard metric drills; however, Table 2 gives the nearest standard metric drill size.

6.2.2 *Area-Amplitude Set*—The area-amplitude set consisting of eight ultrasonic standard reference blocks is listed in Table 3. Area-amplitude relationships at one metal distance are obtained by intercomparison of blocks in this set.

6.2.3 *Distance-Amplitude Set*—A distance-amplitude set may include any convenient number of the reference blocks shown in Table 4 and does not necessarily include all blocks listed. A recommended distance-amplitude set contains at least 12 blocks, and each set contains only one of the three hole sizes shown in Table 4. Blocks comprising the 19 block distance-amplitude sets, which are customarily supplied commercially, are indicated in Table 4. Increments of metal distance in each of the three groups of blocks in the recommended set should be identical. Distance-amplitude relationships are obtained by intercomparison of all blocks containing the same size hole.

TABLE 1 Dimensions and Identification of Reference Blocks in the Basic Set (see Fig. 1)

Block Identification Number	Hole Diameter (A)		Metal Distance (B)		Overall Length (C)	
	1/64 ths in.	in.	mm	in.	mm	
3-0300	3	3.000	76.2	3.750	95.2	
5-0012	5	0.125	3.2	0.875	22.2	
5-0025	5	0.250	6.4	1.000	25.4	
5-0050	5	0.500	12.7	1.250	31.8	
5-0075	5	0.750	19.0	1.500	38.1	
5-0150	5	1.500	38.1	2.250	57.2	
5-0300	5	3.000	76.2	3.750	95.2	
5-0600	5	6.000	152.4	6.750	171.4	
8-0300	8	3.000	76.2	3.750	95.2	
8-0600	8	6.000	152.4	6.750	171.4	

TABLE 2 Diameter of Flat-Bottom Holes in Inch-Pound Units and the Nearest Metric Drill Hole Diameter

NOTE 1—Ratio of the area of the nearest metric drill size to the area of the inch-pound drill size is 1.016 throughout.

Hole Diameter in Inch-Pound Units, in.	Nearest Metric Drill Size, mm
1/64	0.40
2/64	0.80
3/64	1.20
4/64	1.60
5/64	2.00
6/64	2.40
7/64	2.80
8/64	3.20

TABLE 3 Dimensions and Identification of Reference Blocks in the Area-Amplitude Set (see Fig. 1)

Block Identification Number	Hole Diameter (A)		Metal Distance (B)		Overall Length (C)	
	¹ / ₆₄ ths in.	in.	mm	in.	mm	
	1-0300	1	3.000	76.2	3.750	95.3
2-0300	2	3.000	76.2	3.750	95.3	
3-0300	3	3.000	76.2	3.750	95.3	
4-0300	4	3.000	76.2	3.750	95.3	
5-0300	5	3.000	76.2	3.750	95.3	
6-0300	6	3.000	76.2	3.750	95.3	
7-0300	7	3.000	76.2	3.750	95.3	
8-0300	8	3.000	76.2	3.750	95.3	

Area-amplitude relationships are obtained by intercomparison of any three or more blocks containing the same metal distance.

6.3 If the blocks are to be used for immersion testing, they should be suitably anodized or otherwise protected to enhance resistance to corrosion. Blocks with coated surfaces may be used with search units requiring external ground provided suitable arrangements are made for adequate electrical contact. Uncoated blocks shall be designated as Type 1; coated blocks shall be designated as Type 2. The ultrasonic characteristics of both types shall be checked by the immersion method as prescribed in Section 11. However, care must be exercised to dry the Type 1 blocks subsequent to immersion in water. The protective coating used on the Type 2 blocks shall not change their ultrasonic characteristics.

6.4 A number of important variables that affect the response from reference blocks can be controlled during fabrication by accurate machining practices. The roughness of the entry surface; the alignment of entry surface, hole bottom, and back surface; and the surface condition of the hole bottom are the more important physical variables that must be controlled during the fabrication of reference blocks. The quality of material used for blocks also is a factor.

7. Material

7.1 The recommended material for reference blocks is 7075-T6 aluminum alloy rolled or extruded rod (see 13.2).

NOTE 4—To normalize ultrasonic transmission characteristics, the bar stock may be re-heat treated *prior* to manufacturing the blocks. If this option is elected, a recommended practice is soaking at $870 \pm 10^\circ\text{F}$ (465

TABLE 4 Dimensions and Identification of Reference Blocks in Distance-Amplitude Sets (see Fig. 1 and refer to 6.2.3)

Block Identification Number, 3-, 5-, and 8- ^A	Metal Distance (B)		Overall Length (C)	
	in.	mm	in.	mm
-0006 ^B	0.0625	1.6	0.812	20.6
-0012 ^B	0.125	3.2	0.875	22.2
-0025 ^B	0.250	6.4	1.000	25.4
-0038 ^B	0.375	9.5	1.125	28.6
-0050 ^B	0.500	12.7	1.250	31.8
-0062 ^B	0.625	15.9	1.375	34.9
-0075 ^B	0.750	19.1	1.500	38.1
-0088 ^B	0.875	22.2	1.625	41.3
-0100 ^B	1.000	25.4	1.750	44.5
-0125 ^B	1.250	31.8	2.000	50.8
-0150	1.500	38.1	2.250	57.2
-0175 ^B	1.750	44.5	2.500	63.5
-0200	2.000	50.8	2.750	69.9
-0225 ^B	2.250	57.2	3.000	76.2
-0250	2.500	63.5	3.250	82.6
-0275 ^B	2.750	69.9	3.500	88.9
-0300	3.000	76.2	3.750	95.3
-0325 ^B	3.250	82.6	4.000	101.6
-0350	3.500	88.9	4.250	108.0
-0375 ^B	3.750	95.3	4.500	114.3
-0400	4.000	101.6	4.750	120.7
-0425 ^B	4.250	108.0	5.000	127.0
-0450	4.500	114.3	5.250	133.4
-0475 ^B	4.750	120.7	5.500	139.7
-0500	5.000	127.0	5.750	146.1
-0525 ^B	5.250	133.4	6.000	152.4
-0550	5.500	139.7	6.250	158.8
-0575 ^B	5.750	146.1	6.500	165.1
-0600	6.000	152.4	6.750	171.5
-0625	6.250	158.8	7.000	177.8
-0650	6.500	165.1	7.250	184.2

^AHole diameters (A) ³/₆₄, ⁵/₆₄, and ⁷/₆₄ in.

^BBlocks customarily included in commercial 19 block distance-amplitude sets.

$\pm 5^\circ\text{C}$) for a period of $1 \text{ h} \pm 5 \text{ min}$, quenching immediately by immersing vertically into water at room temperature, aging in air at room temperature for 4 days $\pm 1 \text{ h}$, followed by air aging at $250 \pm 10^\circ\text{F}$ ($120 \pm 5^\circ\text{C}$) for $24 \pm 1 \text{ h}$. To minimize distortion during vertical quenching, it is recommended that stock be re-heat treated in lengths of approximately 20 in. (508 mm).

7.2 The stock shall not be less than 2.00 in. (50.8 mm) nor more than 2.25 in. (57.2 mm) in diameter and up to 7.25 in. (184 mm) in length for the blocks covered by this practice.

8. Quality of Material

8.1 The quality of material to be used for reference blocks should be checked by the procedure outlined in 8.2 to 8.9 inclusive. Only material passing the requirements given in 8.9 should be used for blocks.

8.2 *Evaluation Procedure*—The general evaluation procedure consists of directing a beam of pulsed longitudinal waves into the stock in a diametrical direction and noting the ultrasonic noise level. An ultrasonic test by the immersion method using clean water that is free of air bubbles as a couplant is employed for this evaluation.

8.3 *Test Instrument*—Any of several commercially available pulse-echo type ultrasonic testing instruments that provide a 10-MHz test frequency may be used for evaluation of stock quality. The instrument should be capable of providing the required sensitivity level with negligible internal electrical noise and should provide linear amplification of received pulses in an amplitude range of at least 50 % of maximum amplitude of indication on its display screen.

8.4 *Test Frequency*—The test frequency to be used for evaluation of the quality of the reference block material shall be 10 MHz.

8.5 *Search Unit*—An immersion type search unit containing an 0.38-in. (9.5-mm) diameter piezoelectric transducer attached to an appropriate search tube shall be used.

8.6 *Immersion Equipment*—The required pieces of auxiliary equipment are as follows:

8.6.1 A tank of sufficient capacity to facilitate testing of stock.

8.6.2 A search unit holding and manipulating device.

8.6.3 A suitable traversing bridge to provide angulation and lateral positioning of the search unit.

8.7 *Adjustment of Sensitivity*—Determine test sensitivity by directing the ultrasonic beam to an 0.1875-in. (4.8-mm) diameter steel ball, of ball bearing quality, attached to a suitable holding device which is immersed in the water. The water distance to the ball (crystal surface to ball surface) should be 6.0 ± 0.1 in. (152 ± 2.5 mm). Manipulate the search tube to obtain a maximum indication from the ball. Then set the amplitude of this indication by suitable adjustment of the sensitivity (or gain) control of the instrument at 50 % of the maximum possible indication obtainable on the display screen.

8.8 *Details of Evaluation Procedure*—Position the search unit to obtain a maximum number of back reflections through the diameter of the stock using a water distance of 2.0 ± 0.1 in. (50.8 ± 2.5 mm). Then scan the test piece longitudinally and observe the maximum height of the ultrasonic noise level. Make another similar longitudinal scan subsequent to rotating the test piece 90° . Check alignment of the search unit periodically during the scans. Proper alignment of the ultrasonic beam with respect to the test piece exists only when a maximum number of back reflections is maintained.

8.9 *Basis of Acceptance*—The material is acceptable if the maximum magnitude of indications in the ultrasonic noise level does not exceed 20 % of the maximum magnitude of indication obtained from the 0.1875-in. (4.8-mm) diameter steel reference ball. At least five back reflections should be observed at all times during the scanning procedure. Acceptable block material shall not contain discontinuities in excess of the ultrasonic noise level.

9. Procedure for Fabricating Blocks

9.1 Machine reference blocks to a uniform finish within the dimensional tolerances given in 9.2 to 9.10, inclusive, and as specified in Fig. 1. Dimensions of each block are given in Table 1, Table 3, and Table 4.

9.2 *Final Diameter of Block*—Finish the block to a true diameter of 2 ± 0.020 in. (50.8 ± 0.51 mm) and a surface finish of 63 μ in. (1.6 μ m) rms, or smoother.

NOTE 5—The close tolerance on the diameter is to assure a good fit in the holders that are sometimes used for retaining blocks.

9.3 *End Facing*—The machined ends shall be flat within 0.0002 in. (0.005 mm) and perpendicular to the longitudinal axis. The two ends shall be parallel within 0.001 in. (0.03 mm). The surface finish of the entry surface shall be 30 μ in. (0.76 μ m) rms, or smoother, and the back surface 63 μ in. (1.6 μ m) rms, or smoother.

9.4 *Hole Alignment*—The hole must be perpendicular to the end of the block within a tolerance of 30 min. The hole should be located within 0.010 in. (0.25 mm) of the longitudinal axis of the block.

9.5 *Hole Bottom*—Make the hole bottom flat by final drilling with a flat-end drill or cutter. The end of the drill or cutter used for this purpose should be flat within 0.001 in. (0.03 mm) per 0.125 in. (3.2 mm) of diameter and should be perpendicular to its longitudinal axis. The final depth of the finished flat-bottom hole is 0.75 in. (19.0 mm). Make the finished hole bottom as smooth as possible.

9.6 *Counterbore for Plug*—Machine a flat counterbore, 0.250 in. (6.35 mm) in diameter by 0.063 in. (1.62 mm) deep, into the end of the block at its center as shown in Fig. 1.

9.7 *Cleaning and Drying Hole*—Upon completion of the counterboring and drilling operations, clean the hole bottom with a suitable cleaning fluid and dry with a fine stream of dried, filtered, compressed air blown through a capillary tube inserted in the hole.

9.8 *Deburring*—Remove all burrs resulting from the machining procedure. Round the outside edges of entry and back surfaces to a radius of not more than 0.032 in. (0.81 mm).

9.9 *Block Identification*—Identify each reference block by a stenciled block identification number, designating hole size, and metal distance, as given in Table 1, Table 3, and Table 4. In the case of additional and equivalent blocks, as defined in 13.1, which are fabricated to a precise metric system dimension or to mixed English/metric dimensions, the metric dimension shall be indicated by the marking “mm” immediately following the dimension number. For example, a block with a $\frac{5}{64}$ in. diameter flat-bottom-hole target and a 3 mm metal path would be identified as “5-3 mm” and a block with a 1 mm diameter flat-bottom-hole target and a 1 in. metal path would be identified as “1 mm-0100”. The size and location of the stenciled numbers are indicated in Fig. 1. Take special care to protect the block, particularly the entry surface, from handling marks and scratches during the stenciling operation. Stamp or stencil on the block additional information designating the manufacturer and compliance with this practice (see 11.9). However, this information should be located at a point at least 90° about the periphery from the aforementioned block identification number. Letter size and spacing of this additional information should not be greater than letter size and spacing used for the identification number.

9.9.1 Ink identification may be written on the block sound entry surface provided that it has been established that the markings do not affect the block’s measured echo-amplitude response. Etching, scratching, or physical defacing of the block’s sound entry surface is not permitted.

9.10 *Plugging Procedure*—Check the completed unplugged reference block for ultrasonic response prior to plugging. Plug a reference block that exhibits satisfactory ultrasonic response by seating an aluminum plug of the same alloy (7075-T6) that has an interference fit of 0.0005 in. (0.013 mm) in the counterbore. Coat both the counterbore and the faying surface of the plug with a permanent water-impervious rubber-base adhesive before the plug is driven into place. The exposed

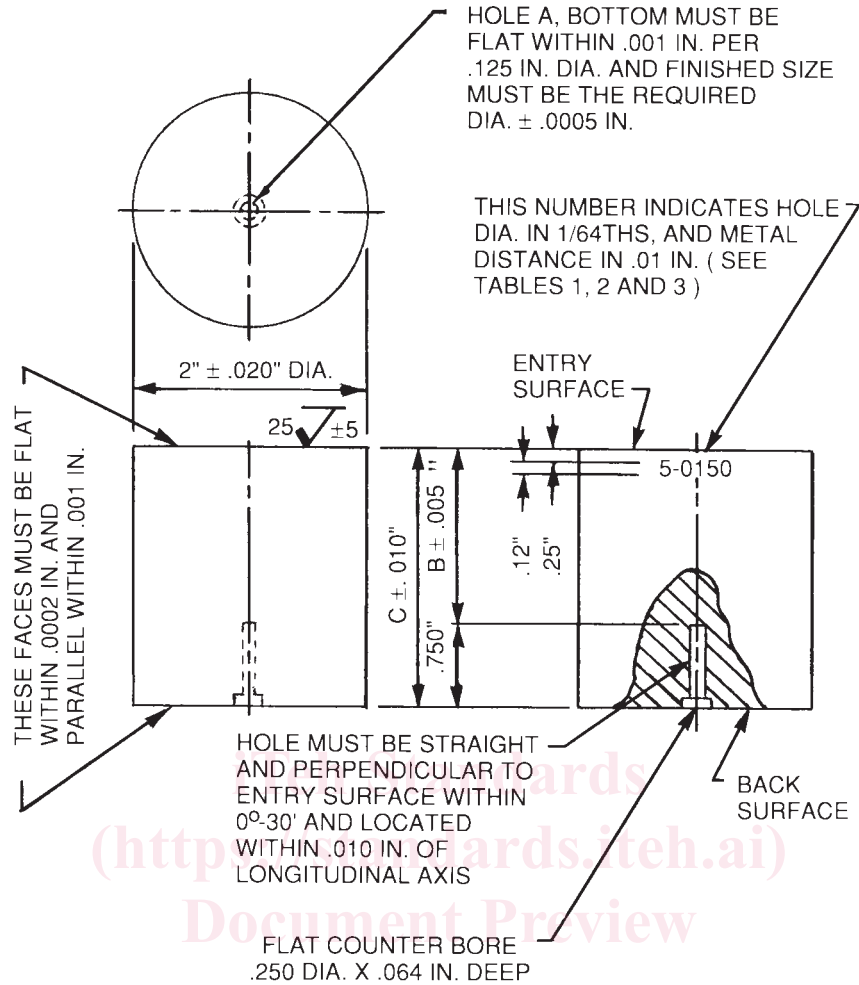

ASTM E127-98
 https://standards.iteh.ai/catalog/standards/sist/52476311719 EXCEPT AS NOTED 3248d96/astm-e127-98
 1 in. = 25.4 mm
FIG. 1 Ultrasonic Standard Reference Block

surface of the seated plug can be slightly below, but should not extend above, the surface.

10. Procedure for Checking Physical Characteristics of Blocks

10.1 *Entry Surface*—Check each finished reference block to ensure flatness and parallelism of entry surface and back surface. A dial gage reading to 0.0001 in. (0.003 mm) and a surface plate may be used for this check. A finished reference block exhibiting misalignment greater than 0.001 in. (0.03 mm) or lack of flatness greater than 0.0002 in. (0.005 mm) over the entire entry surface area is not acceptable.

10.2 *Entry Surface Roughness*—Roughness of the entry surface may be checked using any one of several commercially available roughness measuring instruments. The recommended procedure involves moving the roughness detector (scanning device) of the instrument diametrically across the entry sur-

face. Note deviation in surface roughness during the scan. Finished blocks shall have a surface roughness no greater than 30 µin. (0.75 µm).

11. Procedure for Checking Ultrasonic Characteristics of Blocks

11.1 *Reasons for Ultrasonic Check*—A fabricated block exhibiting satisfactory external physical characteristics must be subjected to additional ultrasonic tests by the immersion method in order to check the characteristics of the hole and hole bottom. The ultrasonic tests consist of checking the response from the block as well as checking for possible angular error. The block response is a function of smoothness and flatness of the hole bottom. Angular error will result from misalignment of the hole bottom with respect to the entry surface. Because poor response from a fabricated block may be alleviated by additional cleaning of the hole bottom, make the

initial ultrasonic check prior to sealing the hole with a permanent aluminum plug.

11.2 *Test Frequency*—Use a test frequency of 5 MHz to check reference blocks.

11.3 *Apparatus:*

11.3.1 *Test Instrument*—Any of several commercially available pulse-echo type ultrasonic testing instruments that employ a *tuned pulse* to provide a test frequency of 5 MHz and that facilitate tests by the immersion method may be used for checking reference blocks. The instrument used should provide stable, linear amplification of received pulses at the required sensitivity levels and should be free of interface signal interference. An appropriate line voltage regulating transformer shall be used to ensure maximum regulation, if not provided internal to the instrument. The instrument calibration shall be checked in accordance with the procedure outlined in 11.4.

11.3.2 *Tank*—Any container is satisfactory that will facilitate the accurate positioning of the reference blocks being checked, the fundamental standard reference balls, and the search unit.

11.3.3 *Manipulator and Bridge*—If a manipulator is used, it should adequately support a search tube and should provide fine adjustment of angle within 1° in two vertical planes that are normal to each other. The bridge should be of sufficient strength to support the manipulator rigidly and should allow smooth accurate positioning of the search unit. Special fixtures may be used provided they meet the requirements prescribed for a manipulator and bridge.

11.3.4 *Couplant*—Clean water, free of air bubbles, should be used as a couplant. Inhibitors or wetting agents, or both, may be used if it is established that their use does not alter the ultrasonic characteristics of the couplant. However, it is important that the same water, at the same temperature, be used for comparing the response from different reference blocks.

11.3.5 *Search Unit*—An immersion search unit having the performance characteristics described in 11.5 shall be used. It shall comprise an X-cut quartz transducer element resonant at 5.0 MHz, and having the diameter and electrode configuration required to produce the specified beam characteristics.

NOTE 6—During the development of this practice, search units with quartz elements having the following dimensions were used:

(1) element diameter—0.5 in. (12.7 mm)

(2) back electrode diameter—0.375 in. (9.53 mm)

(3) front electrode—entire face and edge to provide 360° ground connection

These and later similar units conforming to this practice, are often referred to as having a “ $\frac{3}{8}$ -in. effective diameter”.

11.4 *Qualification of Test System:*

11.4.1 *Reasons for Qualification*—Because differences usually exist in the amplification characteristics of receivers or echo-amplifiers in various test instruments, changes in the amplitude of ultrasonic indications might not be displayed linearly over the entire readable range on the screen of a test instrument. In order to establish correctly the required characteristics of the test system used to check reference blocks, it is necessary to determine the actual linear range of the test system.

11.4.2 *Apparatus*—The same apparatus, including the test instrument, tank and manipulator, and search unit prescribed for checking reference blocks (see 11.3) shall be used to check the linearity of the test system.

11.4.3 *Procedure for Checking Linearity*—Determine the vertical linearity characteristics of the test system in accordance with Practice E 317. For checking the response of reference blocks, use only that portion of the vertical instrument deflection that lies within $\pm 5\%$ of a constant response ratio. This will define the upper and lower linearity limit.

11.5 *Qualification of Search Unit:*

11.5.1 *Reasons for Qualification*—In order to ensure maximum accuracy during the check of block response, check the characteristics of the search unit and use only search units exhibiting acceptable characteristics for this work. The characteristics of the search unit include the following:

11.5.1.1 Frequency,

11.5.1.2 A distance-amplitude curve from a 0.500-in. (12.7-mm) diameter steel ball in water, and

11.5.1.3 Beam profiles obtained from a 0.500-in. (12.7-mm) diameter ball in water.

11.5.2 *Apparatus*—The apparatus used for checking the ultrasonic characteristics of the search unit is the same as that prescribed in 11.3 for checking reference blocks. The manipulator should allow a range in water path from 0 to at least 6 in. (152.4 mm). The steel balls required shall be of ball-bearing quality, free of corrosion and surface marks.

11.5.3 Verify the center frequency of the search unit and system to be 5.0 ± 0.5 MHz.

11.5.4 *Procedure for Obtaining Distance-Amplitude Characteristics*—Obtain an initial response from a 0.500-in. (12.7-mm) diameter steel ball that is located at a water distance of 3.2 to 3.5 in. (81.3 to 88.9 mm). Position the search unit for a maximum indication from the ball under these conditions. Take care to obtain a true maximum indication because the position of the search unit is critical. Subsequent to obtaining the maximum response, adjust the instrument gain control to obtain an indication that is 100 % of the upper linearity limit of the instrument. Then vary the water distance in increments no greater than 0.125 in. (3.2 mm) through a range from 0.25 in. (6.4 mm) to the Y_0^+ point, and from this point in increments no greater than 0.5 in. (12.8 mm) to 6 in. (152.4 mm). Because only the axial distance-amplitude response is required, take care to maintain the location of the ball on the central axis of the beam for each increment of water distance. Plot the incremental response from the ball as a function of water distance. A typical response curve for an acceptable search unit is shown in Fig. 2. Only a search unit with a measured Y_0^+ point at 3.2 to 3.5 in. and a distance-amplitude curve similar to that shown in Fig. 2 will display sets of amplitude response curves equivalent to those required by 11.8.1 and 11.8.2.

11.5.5 *Procedure for Obtaining Beam Patterns:*

11.5.5.1 Obtain the beam characteristics from a 0.500-in. (12.70-mm) diameter steel ball immersed in water at a distance equal to the last maximum amplitude point as determined in 11.5.4. This is the point labeled Y_0^+ in Fig. 2. This plot is obtained by observing the height of indication from the ball while the ball passes under the search unit along its diameter.