



Designation: E1129/E1129M – 08^{ε1}

Standard Specification for Thermocouple Connectors¹

This standard is issued under the fixed designation E1129/E1129M; the number immediately following the designation indicates the year of original adoption or, in the case of revision, the year of last revision. A number in parentheses indicates the year of last reapproval. A superscript epsilon (ϵ) indicates an editorial change since the last revision or reapproval.

^{ε1} NOTE—The year date was corrected editorially in July 2009.

1. Scope

1.1 This specification covers separable single-circuit thermocouple connectors with two round pins. Connectors covered by this specification must be rated for continuous use to at least 300 °F (150 °C), but they may optionally be rated higher.

1.2 This specification does not cover multiple-circuit connectors, multi-pin connectors, miniature connectors, or connectors intended primarily for panel mounting. High temperature connectors (for example, those designed for continuous use at temperatures above approximately 500 °F (260 °C)) are not intended to be covered by this specification.

1.3 The values stated in either inch-pound units or SI units are to be regarded separately as standard.

1.4 The following precautionary statement pertains only to the test method portion, Section 9, of this specification. *This standard does not purport to address all of the safety concerns, if any, associated with its use. It is the responsibility of the user of this standard to establish appropriate safety and health practices and determine the applicability of regulatory limitations prior to use.*

2. Referenced Documents

2.1 The following documents of the latest issue form a part of this specification to the extent referenced herein. In case of conflict between this specification and another referenced document, this specification shall take precedence.

2.2 ASTM Standards:²

E230 Specification and Temperature-Electromotive Force (EMF) Tables for Standardized Thermocouples

E344 Terminology Relating to Thermometry and Hydrometry

¹ This specification is under the jurisdiction of ASTM Committee E20 on Temperature Measurement and is the direct responsibility of Subcommittee E20.04 on Thermocouples.

Current edition approved Nov. 15, 2008. Published January 2009. Originally approved in 1986. Last previous edition approved in 2002 as E1129 – 98(2002). DOI: 10.1520/E1129_E1129M-08E01.

² For referenced ASTM standards, visit the ASTM website, www.astm.org, or contact ASTM Customer Service at service@astm.org. For *Annual Book of ASTM Standards* volume information, refer to the standard's Document Summary page on the ASTM website.

E608 Specification for Mineral-Insulated, Metal-Sheathed Base Metal Thermocouples

3. Terminology

3.1 *Definitions*—The definitions given in Terminology E344 shall apply.

3.2 Definitions of Terms Specific to This Standard:

3.2.1 *connector pair, n*—an assembly consisting of a plug and a jack, each having both positive and negative inserts, that will connect two parts of an electrical circuit and provide a means of physically disconnecting the two parts without the use of tools.

3.2.2 *contact insert, n*—metallic conductor assemblies that, when installed in connector bodies, provide connections between two parts of an electrical circuit. Plug connectors will contain projecting prong contacts, while jack connectors will contain recessed socket or receptacle contacts.

3.2.3 *service life, n*—interval of time that a connector assembly will be put to use and retain all physical and thermoelectric properties.

3.2.4 *test difference, n*—apparent thermoelectric difference attributable to mated connectors observed by the test procedure of this specification.

4. Significance and Use

4.1 The widespread use of thermocouple connectors requires standardization of mating dimensions and performance characteristics.

4.2 This specification describes standardized thermocouple connector dimensions and capabilities and includes test procedures suitable for evaluating the performance of a particular specimen or design. The tests described are not intended for routine inspection or rapid testing of large groups of connectors or for quality control purposes.

5. Classification

5.1 Plugs or Jacks:

5.1.1 Connectors shall be constructed as either plugs or jacks, and these two forms shall be designed to connect with each other.

5.1.2 Plug connectors shall have two external prong contacts of differing diameters to prevent improper mating. The negative prong shall be the larger, as shown in Table 1 and Fig.

TABLE 1 Dimensions

Dimension	Symbol ^A	Minimum, in. (mm)	Maximum, in. (mm)
Body length	L	...	1.505 (38.23)
Body width	W	...	1.088 (27.64)
Body thickness	T	...	0.515 (13.08)
Length of prong	P	0.535 (13.59)	0.650 (16.51)
Depth of socket	J	0.650 (16.51)	...
Prong spacing	X	0.432 (10.97)	0.442 (11.23)
Positive pin diameter	D1	0.152 (3.86)	0.158 (4.02)
Negative pin diameter	D2	0.182 (4.62)	0.190 (4.83)
Location of detent	E	0.180 (4.57)	0.200 (5.08)
Width of detent	G	0.040 (1.02)	...
Depth of detent	F	0.010 (0.25)	0.025 (0.64)

^A Symbols are according to Fig. 3.

1.

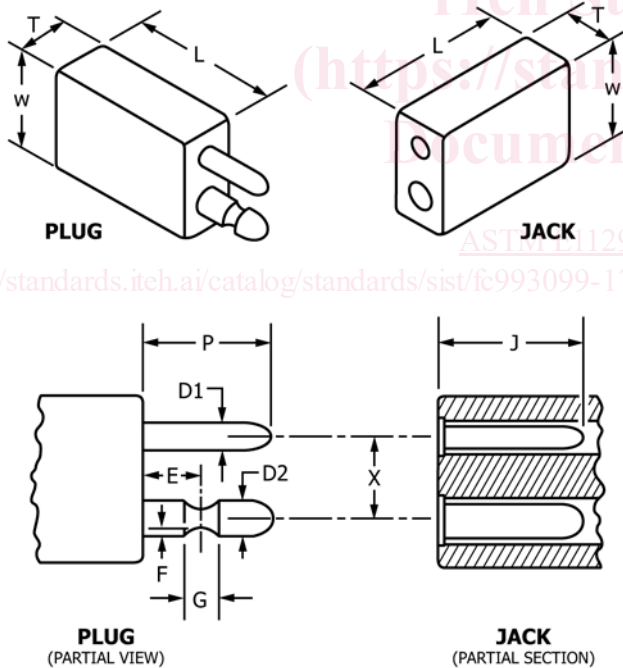

NOTE 1—A solid prong is shown for clarity of design.
 FIG. 1 Thermocouple Connector Dimensions, (see Table 1)

5.1.3 Jack connectors shall have two internal socket contacts sized and spaced to receive and accommodate the prong contacts of the mating plug. Jack connectors shall also include a means of producing and maintaining sufficient contact pressure to meet all of the other requirements of this specification.

5.2 ANSI/ASTM Type:

5.2.1 Connectors shall be produced in versions to match each of the standardized ANSI/ASTM thermocouple types as given in Table 2.

5.2.2 The insert materials of each plug and jack shall have thermoelectric properties conforming to the characteristics of extension grade material of the corresponding thermocouple type as given in Specification E230 over the temperature range specified in Table 3.

5.2.3 Calibration conformance and gradient testing is not applicable to Type B thermoelectrically neutral (Cu/Cu) connectors.

6. Ordering Information

6.1 Orders for connectors under this specification shall include the following:

- 6.1.1 Quantity of plugs or jacks (specify which),
- 6.1.2 ANSI/ASTM thermocouple type (see Table 2),
- 6.1.3 Any optional accessories that may be required, such as those listed in 7.4.3,
- 6.1.4 Special testing requirements, and
- 6.1.5 Requirements for certificates of conformance to the specifications or reports of the results of any required testing.

7. Materials and Manufacture

7.1 Body:

7.1.1 The dimensions of the connector bodies shall fall within the limits given in Table 1.

7.1.2 The connector body shall be made of an electrically insulating material capable of continuous use at any temperature between 0 °F (-18 °C) and 300 °F (150 °C) for the service life given in Table 2, without losing its ability to conform to this specification.

7.1.3 The connector bodies shall be color coded in accordance with Table 2 to provide rapid and permanent identification of the thermocouple calibration with which it is designed to be used. Each plug and jack shall be permanently marked with a symbol or symbols to identify positive and negative conductor inserts. All connectors shall bear the supplier's name or other means of source identification, unless otherwise specified in the purchasing documents.

7.1.4 An insulating barrier shall be incorporated into each connector body to prevent inadvertent contact between thermoelements or wires.

7.2 Inserts:

7.2.1 Contact inserts may be either solid or hollow as long as all of the requirements of this specification are met.

TABLE 2 Identification

ANSI/ASTM Type	Body Color Coding
T	Blue
J	Black
E	Purple
K	Yellow
N	Orange
R or S	Green
B (Cu/Cu) ^A	White

^A Uncompensated (Cu/CU) connectors are customarily used with Type B thermocouples.



TABLE 3 Specifications

Characteristic	Min	Max	Requirement	Test Procedure
Operating Temperature	0 °F (–18 °C)	300 °F (–150 °C)	7.1.2	9.6
Engagement Force	6 lb (27 N)	18 lb (80 N)	7.2.4	9.5
Disengagement Force	6 lb (27 N)	18 lb (80 N)	7.2.4	9.5
Contact resistance (each leg)	...	0.04 ohms	7.2.7	9.2
Insulation resistance at Room Temperature	10 ⁷ ohms	...	7.3.4	9.4
Insulation Resistance at 300 °F (150 °C)	7.3.4	9.4
Thermal Gradient	...	±2 °F (±1.1 °C)	7.2.8	9.3
Repeated cycles (Engagement)	25	...	7.2.5	9.6

7.2.2 Contact inserts shall be fabricated of materials that meet the requirements of Section 5.

7.2.3 The inside diameter and depth of the jack connector shall be such as to receive the corresponding plug prong smoothly and easily when inserted. A spring loaded detent device shall be incorporated in the negative side of the jack connector to engage the detent in the negative plug prong. The function of the detent system shall be to cause positive locking together of a plug and jack when fully mated. The detent system shall not permit the two connectors to be separated by more than 0.03 in. (0.8 mm) when subjected to a withdrawal force less than the minimum given in Table 3.

7.2.4 The forces required for complete engagement or disengagement shall be within the limits listed in Table 3.

7.2.5 The connector pair shall be capable of repeated insertion and withdrawal cycles as given in Table 3 without losing the ability to conform to the requirements of this specification.

7.2.6 The dimensions and locations of the inserts in the connector bodies shall fall within the limits given in Table 1.

7.2.7 The contact resistance between the assembled plug and jack shall conform to the requirements of Table 3.

7.2.8 The connector pair shall be capable of passing the thermal gradient test specified in Table 3.

7.3 Construction and Assembly:

7.3.1 Wire attachment shall be by means of a screw or clamp suitable for use with wire diameters from 30 AWG (0.01 in. or 0.25 mm in diameter) to 18 AWG (0.04 in. or 1.0 mm in diameter).

7.3.2 Contact inserts and wire attaching parts shall be held captive to one of the body parts.

7.3.3 Connections and final closures of the connector shall be accomplished with simple hand tools such as screwdrivers, wrenches, or pliers.

7.3.4 The assembled connector shall be capable of passing the insulation resistance requirements listed in Table 3 at the temperatures listed.

7.3.5 The materials and construction used in the connector shall be such that the connector will meet all of the specified requirements for the service life interval listed in Table 33.

7.4 Optional Accessories:

7.4.1 Connector accessories are not covered by this specification and may be unique to a manufacturer's specific design.

7.4.2 All required optional accessories are to be specified separately from the connectors.

7.4.3 The following is a partial list of useful accessory items:

7.4.3.1 Cable clamping devices, for attaching flexible cables;

7.4.3.2 Clamps for rigid tubing and sheaths in a range of diameters as listed in Specification E608;

7.4.3.3 Elastomeric boots to seal connector assemblies against moisture in service;

7.4.3.4 Safety clamps or other devices to prevent inadvertent separation of connectors under conditions of severe vibration; and

7.4.3.5 Flat washers for use under wire attachment screw heads as an aid in the retention of the wires and prevent damage to the wires.

7.4.4 Some suppliers may not offer all of the above items while others may offer additional items. Supplier catalogs and literature should be consulted for details.

8. Physical Properties

8.1 The physical size of connectors conforming to this specification shall fall within the limits given in Table 1 for all dimensions indicated in that table. All other dimensions and all details of construction shall be determined by a manufacturer's specific design.

9. Test Methods

9.1 *Test Frequency:* The following tests shall be conducted as either Qualification or Production tests as follows:

Paragraph Number	Test Description	Type
9.2	Contact Resistance	Qualification
9.3	Thermal Gradient	Qualification
9.4	Insulation Resistance	Qualification
9.5	Engagement/Disengagement Force	Qualification
9.6	Repeated Cycle Test	Qualification
9.7	Service Life Test	Qualification

Tests listed as "Qualification" tests shall be initially performed by the manufacturer to demonstrate conformance to this specification, and then periodically, as determined by the