International Standard



2244

INTERNATIONAL ORGANIZATION FOR STANDARDIZATION • МЕЖДУНАРОДНАЯ ОРГАНИЗАЦИЯ ПО СТАНДАРТИЗАЦИИ • ORGANISATION INTERNATIONALE DE NORMALISATION

Packaging — Complete, filled transport packages — Horizontal impact tests (horizontal or inclined plane test; pendulum test)

Emballages — Emballages d'expédition complets et pleins — Essais de choc horizontal (essai sur plan horizontal ou incliné; essai au pendule)

iTeh STANDARD PREVIEW

Second edition — 1985-11-01 (standards.iteh.ai)

[ISO 2244:1985](#)

<https://standards.iteh.ai/catalog/standards/sist/888f6736-601e-49eb-87c9-caf5182fd4a/iso-2244-1985>

UDC 621.798.1 : 620.165.7

Ref. No. ISO 2244-1985 (E)

Descriptors : packing, transport packing, complete-and filled packages, tests, impact tests.

Foreword

ISO (the International Organization for Standardization) is a worldwide federation of national standards bodies (ISO member bodies). The work of preparing International Standards is normally carried out through ISO technical committees. Each member body interested in a subject for which a technical committee has been established has the right to be represented on that committee. International organizations, governmental and non-governmental, in liaison with ISO, also take part in the work.

Draft International Standards adopted by the technical committees are circulated to the member bodies for approval before their acceptance as International Standards by the ISO Council. They are approved in accordance with ISO procedures requiring at least 75 % approval by the member bodies voting.

International Standard ISO 2244 was prepared by Technical Committee ISO/TC 122, *Packaging*.

ISO 2244 was first published in 1972. This second edition cancels and replaces the first edition, which has been technically revised as follows:

- a horizontal plane test method has been specified;
- a new clause on "Package preparation" has been added.

Users should note that all International Standards undergo revision from time to time and that any reference made herein to any other International Standard implies its latest edition, unless otherwise stated.

Packaging — Complete, filled transport packages — Horizontal impact tests (horizontal or inclined plane test; pendulum test)

1 Scope and field of application

This International Standard specifies methods of horizontal impact testing (horizontal or inclined plane test and pendulum test) on a complete, filled transport package. The test may be performed either as a single test to investigate the effects of horizontal impact or as part of a sequence of tests designed to measure the ability of a package to withstand a distribution system that includes a horizontal impact hazard.

2 References

ISO 2206, *Packaging — Complete, filled transport packages — Identification of parts when testing.*

ISO 2233, *Packaging — Complete, filled transport packages — Conditioning for testing.*

3 Principle

Applying a horizontal velocity to the test package and bringing it to a halt by impact with a vertical impact surface. The atmospheric conditions, the horizontal velocity and the attitude of the package are predetermined. Particular conditions of impact may be simulated by placing appropriately profiled inserts between the impact surface and the impacting face or edge of the test package.

4 Apparatus

4.1 Impact surface, which should be either

- a plane inclined to the vertical at $10 \pm 1^\circ$ (for the inclined plane test), or
- a plane vertical to within 1° (for the horizontal or pendulum test).

The dimensions of the impact surface shall be greater than those of the impacting face, or selected part, of the test package.

The impact surface shall be sufficiently rigid not to deflect more than 0,25 mm when a load of 160 kg/cm² is applied anywhere on the surface.

In addition, the apparatus shall meet the requirements and tolerances specified in clause 7.

4.2 Optional interposed hazards. to be used when it is required to concentrate the impact in a particular area of the test package.

The dimensions, material and location of the interposed hazard shall be carefully specified.

Example: A steel beam with a length of 200 mm and a cross-section of 100 (± 1) mm \times 100 (± 1) mm with rounded edges of radius $5 \pm 0,1$ mm, placed centrally in the impact surface (4.1).

4.3 Impact testing apparatus: Types of apparatus that may be used are described in 4.3.1, 4.3.2 and 4.3.3.

4.3.1 Inclined plane tester, consisting of the following items:

4.3.1.1 Two-rail steel track, inclined at 10° to the horizontal. The distance along the incline shall be graduated at intervals of 50 mm. (See figure 1.)

4.3.1.2 Rolling carriage or dolly: The surface friction between the rolling carriage/dolly and the test package shall be such that during movement from rest to impact the package will not move in relation to the carriage, but such that upon impact the package will move freely.

4.3.1.3 Impact surface (or bumper), meeting the specifications of 4.1, placed at the bottom of the track with its face perpendicular to the direction of movement of the carriage down the track.

NOTES

1 A suitable impact surface comprises a number of heavy timbers mounted horizontally across the face of the structure such that the optional interposed hazard (4.2) can be fitted easily when required.

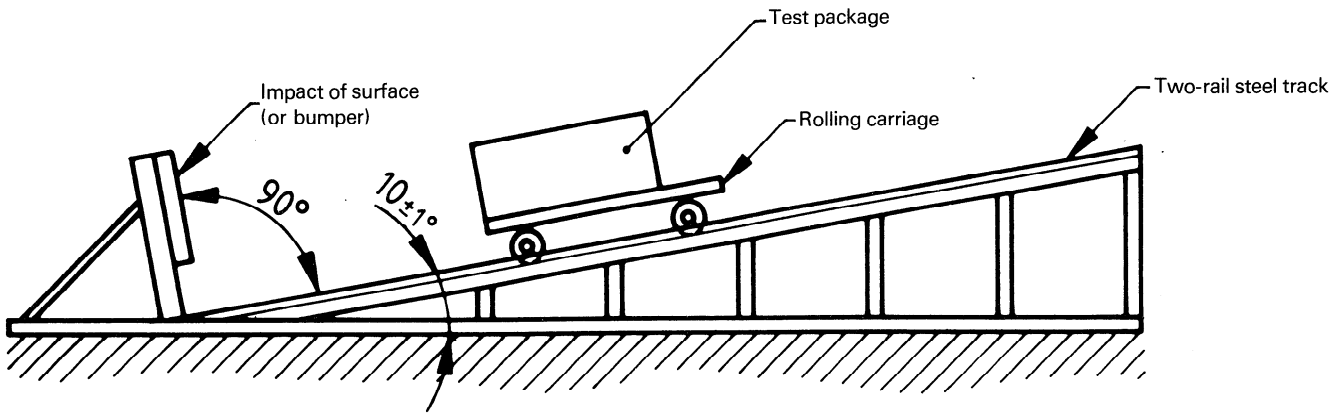

Figure 1 — Inclined plane tester

- 2 It is recommended that the bumper be made in such a way that the carriage can travel underneath it for about 100 mm so that the package impacts the bumper before the carriage stops.
- 3 The apparatus should preferably be equipped with a device to prevent the carriage from rebounding after the impact. Either a spring damper or an oil damper may be incorporated into such a device.
- 4 The track and the wheels shall be kept clean.
- 5 The wheel bearings shall be regularly lubricated. Roller bearings are recommended.

4.3.2 Horizontal plane tester, consisting of the following items:

4.3.2.1 Two-rail steel track fixed in the horizontal plane

4.3.2.2 Rolling carriage or dolly which can be mechanically driven in such a manner that its velocity is known at the moment of impact. The surface friction between the rolling carriage/dolly and the package shall be such that during movement from rest to impact the test package will not move in relation to the carriage, but such that upon impact the package will move freely.

4.3.2.3 Impact surface (or bumper), meeting the specifications of 4.1, at one end of the track with its face perpendicular to within 1° to the direction of movement of the carriage along the track.

4.3.3 Pendulum apparatus, consisting of a rectangular platform suspended at each corner by steel rods or ropes so that in its rest position the front edge just touches the impact surface that meets the specifications of 4.1. The suspension system shall be such that it moves freely and its path is not obstructed when the test package is mounted on the platform. (See figure 2.)

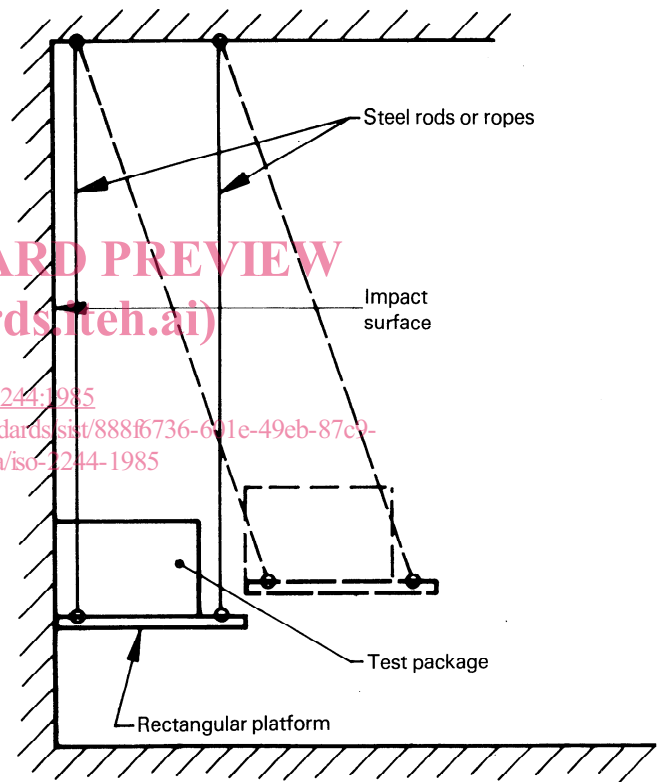

Figure 2 — Pendulum apparatus

4.4 Impact measuring apparatus, if required, on the carriage, allowing measuring and recording of the peak deceleration and impact velocity.

5 Package preparation

The test package shall normally be filled with its intended contents. However, simulated or dummy contents may be used, on condition that the dimensions and physical properties of such contents shall be as close as possible to those of the intended contents.

For certain types of package, such as carboys, it may be sufficient to suspend the test package from a single rod or rope.

In both instances the suspension system shall not impart a rotary movement to the test package.

Ensure that the test package is closed normally, as if ready for distribution. If simulated or dummy contents are used, ensure that the normal method of closure is still employed.

6 Conditioning

The package shall be conditioned in accordance with one of the conditions described in ISO 2233.

7 Procedure

Whenever possible the test shall be carried out in the same atmospheric conditions as used for conditioning, where this is critical to the material or application of the package. In other circumstances, the test shall be carried out in atmospheric conditions which are as near as practicable to those used for conditioning.

The velocity at impact shall be within $\pm 5\%$ of the predetermined horizontal velocity.

When the impact is on a face or edge, the test package shall strike the impact surface so that the angle between the face or edge and the plane of the impact surface is less than 2° .

When the impact is on an edge of a parallelepipedal package, the attitude of the package at impact shall be such that the angle between a set surface of the package and the impact surface is within $\pm 5^\circ$ or $\pm 10\%$ of the predetermined angle, whichever is the greater.

7.1 Procedure for inclined plane test

Place the test package on the carriage in an attitude that will ensure that it strikes the impact surface (4.3.1.3) in the desired position.

Whenever possible the package shall not project beyond the edges of the carriage.

Raise the carriage to that height up the incline (4.3.1.1) which corresponds with the desired impact velocity, then release it.

7.2 Procedure for horizontal plane test

Place the test package on the carriage (4.3.2.2) as described in 7.1.

Set the carriage in motion along the steel track at a velocity predetermined to give the desired impact velocity on the impact surface (4.3.2.3).

7.3 Procedure for pendulum test

Place the test package on the rectangular platform (see 4.3.3 and figure 2) so that the impacting face or edge just touches the impact surface.

Raise the pendulum by pulling out the platform to the distance from the impact surface appropriate to the velocity required, then release it.

8 Test report

The test report shall include the following information:

- a) reference to this International Standard;
- b) number of replicate packages tested;
- c) full description of the package, including dimensions, structural and material specifications of the package and its fittings, cushioning, blocking, closure or reinforcing arrangements;
- d) description of contents — if simulated or dummy contents were used, full details shall be given;
- e) gross mass of package and mass of contents, in kilograms;
- f) relative humidity, temperature and time of conditioning; temperature and relative humidity of test area at time of test; whether these values comply with the requirements of ISO 2233;
- g) attitude in which the package was tested, using the method of identification given in ISO 2206;
- h) velocity at impact, and if required, the peak deceleration;
- i) position and description of interposed hazard, if used;
- k) type of apparatus used;
- m) any deviations from the test method described in this International Standard;
- n) a record of results, with any observations which may assist in correct interpretation;
- p) date of the test;
- q) signature of tester.

iTeh STANDARD PREVIEW

(standards.iteh.ai)
This page intentionally left blank

ISO 2244:1985

<https://standards.iteh.ai/catalog/standards/sist/888f6736-601e-49eb-87c9-caf5182fd4a/iso-2244-1985>

iTeh STANDARD PREVIEW

(standards.iteh.ai)
This page intentionally left blank

ISO 2244:1985

<https://standards.iteh.ai/catalog/standards/sist/888f6736-601e-49eb-87c9-caf5182fd4a/iso-2244-1985>

iTeh STANDARD PREVIEW
(standards.iteh.ai)

This page intentionally left blank

[ISO 2244:1985](#)

<https://standards.iteh.ai/catalog/standards/sist/888f6736-601e-49eb-87c9-caf5182fd4a/iso-2244-1985>