



SLOVENSKI STANDARD
oSIST prEN 1253-6:2020
01-september-2020

Odtoki v stavbah - 6. del: Talni odtoki z zaporo vode na višini manj kot 50 mm

Gullies for buildings - Part 6: Trapped floor gullies with a depth of water seal less than 50 mm

Abläufe für Gebäude - Teil 6: Bodenabläufe mit Geruchverschluss mit einer Geruchverschlusshöhe von weniger als 50 mm

Avaloirs et siphons pour bâtiments - Partie 6 : Siphons de sol avec garde d'eau inférieure à 50 mm

Ta slovenski standard je istoveten z: prEN 1253-6

<https://standards.iteh.ai/catalog/standards/sist/a2339cf9-2be7-4cab-868a-01bf6f10b12f/sist-en-1253-6-2023>

ICS:

91.140.80 Drenažni sistemi Drainage systems

oSIST prEN 1253-6:2020

en,fr,de

EUROPEAN STANDARD
NORME EUROPÉENNE
EUROPÄISCHE NORM

DRAFT
prEN 1253-6

July 2020

ICS 91.140.80

English Version

Gullies for buildings - Part 6: Trapped floor gullies with a depth of water seal less than 50 mm

Avaloirs et siphons pour bâtiments - Partie 6: Siphons de sol avec garde d'eau inférieure à 50 mm

Abläufe für Gebäude - Teil 6: Bodenabläufe mit Geruchverschluss mit einer Geruchverschlusshöhe von weniger als 50 mm

This draft European Standard is submitted to CEN members for enquiry. It has been drawn up by the Technical Committee CEN/TC 165.

If this draft becomes a European Standard, CEN members are bound to comply with the CEN/CENELEC Internal Regulations which stipulate the conditions for giving this European Standard the status of a national standard without any alteration.

This draft European Standard was established by CEN in three official versions (English, French, German). A version in any other language made by translation under the responsibility of a CEN member into its own language and notified to the CEN-CENELEC Management Centre has the same status as the official versions.

CEN members are the national standards bodies of Austria, Belgium, Bulgaria, Croatia, Cyprus, Czech Republic, Denmark, Estonia, Finland, France, Germany, Greece, Hungary, Iceland, Ireland, Italy, Latvia, Lithuania, Luxembourg, Malta, Netherlands, Norway, Poland, Portugal, Republic of North Macedonia, Romania, Serbia, Slovakia, Slovenia, Spain, Sweden, Switzerland, Turkey and United Kingdom.

Recipients of this draft are invited to submit, with their comments, notification of any relevant patent rights of which they are aware and to provide supporting documentation.

Warning : This document is not a European Standard. It is distributed for review and comments. It is subject to change without notice and shall not be referred to as a European Standard.



EUROPEAN COMMITTEE FOR STANDARDIZATION
COMITÉ EUROPÉEN DE NORMALISATION
EUROPÄISCHES KOMITEE FÜR NORMUNG

CEN-CENELEC Management Centre: Rue de la Science 23, B-1040 Brussels

Contents	Page
4.1 General.....	8
4.2 Appearance.....	9
4.3 Apertures in gratings.....	9
4.4 Resistance of water seal to pressure.....	9
4.4.1 Requirements.....	9
4.4.2 Test method.....	9
4.5 Blockage prevention.....	10
4.5.1 Access for cleaning.....	10
4.5.2 Self-cleansing capacity.....	11
4.5.3 Anti-blockage.....	11
4.6 Places of installation.....	11
4.6.1 General.....	11
4.6.2 Exceptions.....	11
4.7 Materials.....	12
4.8 Thermal behaviour of floor gullies.....	12
4.8.1 General.....	12
4.8.2 Requirements.....	12
4.8.3 Test method.....	12
4.8.4 Additional test for floor gullies for use with sheet floor coverings and liquid applied membranes.....	12
4.9 Tightness.....	14
4.9.1 Odour-tightness.....	14
4.9.2 Watertightness of bodies.....	15
4.9.3 Watertightness of extensions.....	15
4.10 Mechanical strength.....	15
4.10.1 Loading strength.....	15
4.10.2 Clamping ring strength.....	17
4.10.3 Additional mechanical strength according to the installation.....	17
4.10.4 Floor gullies for use with liquid applied membranes.....	21
4.11 Flow rates.....	21
4.11.1 Principle.....	21
4.11.2 Requirements.....	21
4.11.3 Test method.....	22
4.11.4 Test arrangement.....	22
Annex A (normative) Sequence of the tests.....	25
Annex B (normative) Examples of top view of the positioning of shape of test blocks applied on the gratings.....	26

European Foreword

This document (prEN 1253-6:2020) has been prepared by Technical Committee CEN/TC 165 “Waste water engineering”, the secretariat of which is held by DIN.

This document is currently submitted to the CEN Enquiry.

Within its program of work, Technical Committee CEN/TC 165 requested CEN/TC 165/WG 11 “Gratings, covers and other ancillary components for use inside buildings” to prepare the following standard:

EN 1253-6, Trapped floor gullies with a depth water seal of less than 50 mm.

The EN 1253 series under the main title Gullies for buildings will actually consist of the following parts:

- *Part 1: Trapped floor gullies with a depth water seal of at least 50 mm;*
- *Part 2: Roof drains and floor gullies without trap;*
- *Part 3: Evaluation of conformity;*
- *Part 4: Access covers;*
- *Part 5: Gullies with light liquids closure;*
- *Part 6: Trapped floor gullies with a depth of water seal less than 50 mm;*
- *Part 7: Trapped floor gullies with mechanical closure;*
- *Part 8: Trapped floor gullies with combined mechanical closure and water seal.*

Since the versions of EN 1253-1 and EN 1253-2, the most significant technical changes are the following:

- a) grouping of “Requirements” and “Test method” articles for a test;
- b) adding Annex B with examples of top view of the positioning of shape of test blocks applied on the gratings;
- c) adding tolerance.

prEN 1253-6:2020 (E)**1 Scope**

This document classifies floor gullies for use inside buildings, gives guidance for places of installation and specifies requirements for the construction, design, performance and marking of factory made gullies for buildings, irrespective of the material, for use in drainage systems requiring a trap with a depth of water seal less than 50 mm (referred to as floor gullies).

NOTE Floor gullies with a depth of water seal less than 50 mm are not covered by Part 1, Part 7, Part 8.

These products are intended to be installed only where:

- space limitation will not accommodate a gully with a 50 mm water sea;
- the building does not exceed a ground-floor and three floors above;
- at least two sanitary appliances are installed in addition to the gully but with only one toilet on the same branch (connection pipe);
- or secondary or branch ventilation is installed according to EN 12056-2, 4.3.2 or 4.3.4.

2 Normative references

The following documents are referred to in the text in such a way that some or all of their content constitutes requirements of this document. For dated references, only the edition cited applies. For undated references, the latest edition of the referenced document (including any amendments) applies.

EN 124 (all parts), *Gully tops and manhole tops for vehicular and pedestrian areas*

EN 476, *General requirements for components used in drains and sewers*

EN 1253-3, *Gullies for buildings — Part 3: Evaluation of conformity*

EN 12056-2, *Gravity drainage systems inside buildings — Part 2: Sanitary pipework, layout and calculation*

3 Terms and definitions

For the purposes of this document, the following terms and definitions apply.

ISO and IEC maintain terminological databases for use in standardization at the following addresses:

- ISO Online browsing platform: available at <https://www.iso.org/obp>
- IEC Electropedia: available at <https://www.electropedia.org/>

3.1 trapped floor gully

discharge fitting the top of which is a grating or cover capable of installation at ground or floor level, intended to receive wastewater either through apertures in the grating and/or channels joined to the body of the gully and to drain that wastewater through the outlet

Note 1 to entry: See Figure 1.

Note 2 to entry: In this European Standard, the term trapped “floor gully” includes linear products, such as channel drains.

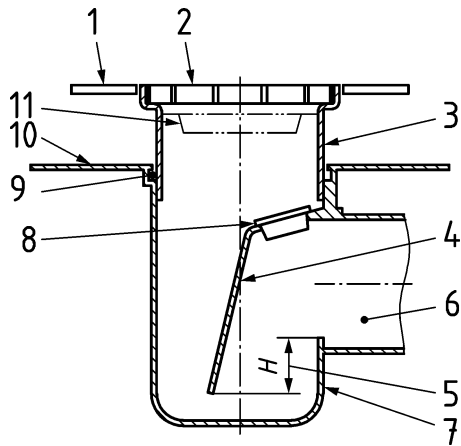

a) Floor gully with side inlets and flange for bonding membranes (example)

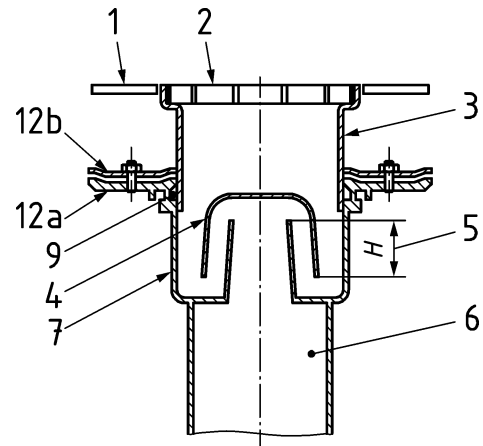

b) Floor gully with flange for clamping membranes (fixed and loose flange) (example)

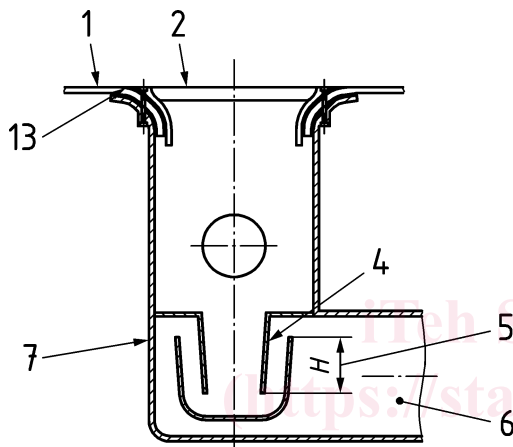

c) Floor gully with side inlets and flange for clamping flexible flooring (e.g. PVC flooring) (example)

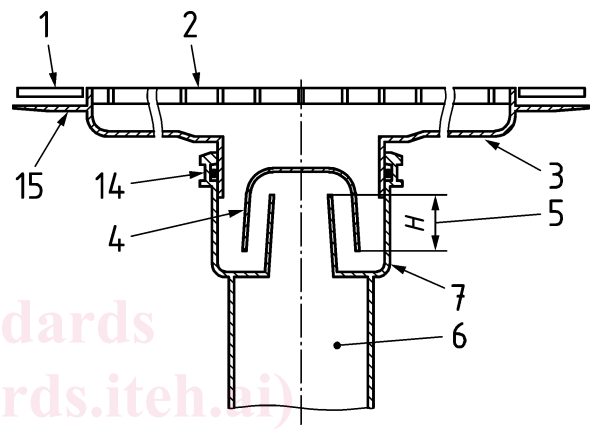

d) Channel drain with flange for bonding liquid applied membranes (example)

Key

1	finished floor	9	weep hole
2	grating/cover	10	flange for bonding membranes
3	extension	11	sediment bucket
4	trap	12	connecting flange with counter flange
5	depth of water seal ($H \geq 50$ mm)	a	fixed flange
6	outlet	b	loose flange
7	body	13	flange for clamping flexible flooring with a clamping ring
8	access for cleaning	14	seal
		15	flange for bonding liquid applied membrane

Figure 1 — Types of floor gullies

3.2

grating

removable component with apertures which permits the discharge of water

prEN 1253-6:2020 (E)**3.3****frame**

support for a grating or cover which is connected to a body either directly or by means of a membrane clamping ring or an extension

3.4**cover**

removable part of an access cover which covers the opening

3.5**body**

part of a floor gully below or in the floor on which the grating/frame/extension is mounted, and to which the pipework is connected

3.6**extension**

component used to adjust the height of a grating or cover above a body

3.7**joint**

connection between the adjacent ends of two components including the means of sealing

3.8**membrane clamping ring**

component used to clamp a membrane or a sheet floor covering to a body or extension

3.9**connecting flange**

separate or an integral part of a body or of an extension which receives a membrane or sheet floor covering

3.10**external diameter**

OD <https://standards.iteh.ai/catalog/standards/sist/a2339cf9-2be7-4cab-868a-01bf6f10b12f/sist-en-1253-6-2023>
mean external diameter of the pipe barrel at any cross section

3.11**internal diameter****ID**

mean internal diameter of the pipe barrel at any cross section

3.12**trap**

removable or integral part of the body which prevents, by means of water seal, the passage of foul air from the outlet to the inlet

3.13**depth of water seal**

effective height of water in the trap (H) which prevents the passage of foul air

Note 1 to entry: See Figure 1.

3.14**domestic wastewater**

water polluted by the human life, including water discharged from kitchens, laundry rooms, lavatories, bathrooms, toilets and similar facilities

[SOURCE: EN 16323:2014, 2.1.2.3]

3.15**sheet floor covering**

flexible watertight finished layer for floors affixed to the flange by bonding, welding and/or by means of a clamping ring

3.16**membrane**

watertight and damp proof layer attached to the floor gully either in the floor or on the floor

3.17**head of water**

depth h of a water line over the frame of the floor gully

Note 1 to entry: See Figure 2.

Note 2 to entry: For floor gullies without frame, the depth of water line is the lowest level over the finished floor.

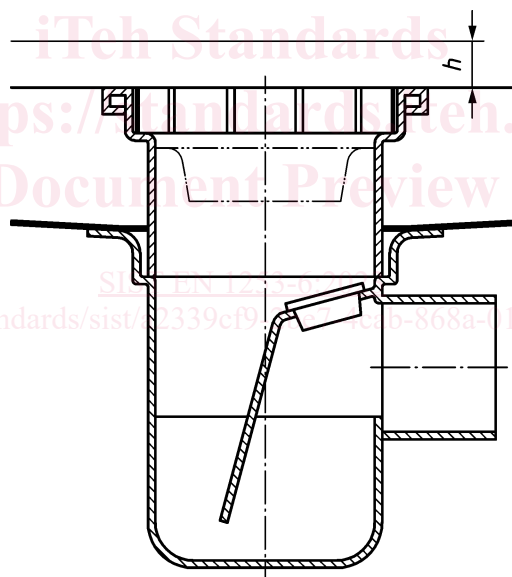
**Key**

h head of water

Figure 2 — Head of water for floor gullies

prEN 1253-6:2020 (E)**3.18****outlet**

male or female connection to the discharge pipe

3.19**nominal size****DN**

numerical indication of size which is a convenient integer approximately equal to the internal diameter (DN/ID) or the external diameter (DN/OD) in millimetres

3.20**clear opening****CO**

diameter of the largest circle that can be inscribed within the unsupported area of the grating

3.21**test load**

specified load which a component is required to withstand

3.22**liquid applied waterproofing kit**

particular combination of a defined set of components to be installed in liquid form for waterproofing by application and/or incorporation and/or joining of the components in accordance with particular design methods

Note 1 to entry: The liquid applied watertight kit is usually a paste-like composite material or a combination of separate materials that can be poured, spread or sprayed on the subsurface by brush, roller or similar suitable applicator.

4 Design and construction**4.1 General**

Floor gullies shall be capable of being connected to the pipework system covered by relevant European Standards, and, when installed in accordance with the manufacturer's instructions, shall form an integral part of the building. There shall be no movement possible between the body and the floor, which would impair the functioning of the installed gully.

In areas where pressure testing of the pipe system is necessary floor gullies for use in the ground floor shall enable such test to be performed.

The upper surfaces of frame and grating shall be flush. When in position, it shall not be possible for gratings and covers to be dislodged from the frame, but they shall be easy to be released for e.g. maintenance and cleaning.

Traps shall be prevented, by design features such as fixings or weights, from uncontrolled floating or becoming displaced.

Floor gullies and their components shall be resistant to normal actions of mechanical and thermal character.

Floor gullies may be designed without side inlet.

Floor gullies shall be delivered with installation instructions.

All pipe joints to and from the floor gully shall be designed to be watertight in accordance with EN 476.

4.2 Appearance

Internal and external surfaces shall be free from sharp edges and imperfections which could impair functioning of the floor gully or give risk of injury.

4.3 Apertures in gratings

Apertures can be holes or slots of any shape and may also be formed between grating and frame.

By means of suitable measuring instruments or balls of suitable sizes, the dimensions of apertures in grating shall be as specified in Table 1.

Table 1 — Apertures in gratings

Class	Dimensions of apertures in gratings	
	Minimum width	Maximum width
H 1,5	4 ^b	15 (max. 8 mm in barefoot areas)
K 3	4 ^b	0 (max. 8 mm in barefoot areas)
L 15 ^a	4	15 (max. 8 mm in barefoot areas)

^a In commercially used premises, gratings may also be used with a maximum width of apertures up to 31 mm.
^b Apertures of less than 4 mm width are permitted but shall not form part of the hydraulic tests.

4.4 Resistance of water seal to pressure

4.4.1 Requirements

The applied pressure which just causes passage of air shall be > 200 Pa.

4.4.2 Test method

Mount the floor gully in a test arrangement as illustrated in Figure 3, and run water through the gully until the trap is filled.

Close the flap and set a pressure of -200 Pa by means of the bypass valves. Open the flap and fill the trap with water.

Close the flap and slowly open after about 5 s. Repeat this procedure until the trap no longer loses water, but no more than 5 times.

Remove 4 mm of water height; this corresponds to the reduction in the depth of water seal due to evaporation over a period of disuse.

Apply to the outlet side a positive pressure such that flow of air just occurs. Record the pressure.

With the flap closed, set the desired negative pressure with the bypass valves, and read the manometer. The sensors in the trap are connected to the recording device. When the flap is closed rapidly, the desired vacuum pressure is established immediately.

By reversing the fan and securing the flap in the closed position, the arrangement can be used also for the measurement of the resistance to positive pressure.