



SLOVENSKI STANDARD
oSIST prEN 1253-7:2020

01-september-2020

Odtoki v stavbah - 7. del: Talni odtoki z mehansko smradno zaporo

Gullies for buildings - Part 7: Trapped floor gullies with mechanical closure

Abläufe für Gebäude - Teil 7: Bodenabläufe mit mechanischem Geruchverschluss

Avaloirs et siphons pour bâtiments - Partie 7: Siphons de sol avec système d'obturation mécanique

(standards.iteh.ai)

Ta slovenski standard je istoveten z: prEN 1253-7

[oSIST prEN 1253-7:2020](https://standards.iteh.ai/catalog/standards/sist/f8929c50-fb5d-4c0d-ac36-7888f2744f4f/osist-pren-1253-7-2020)

<https://standards.iteh.ai/catalog/standards/sist/f8929c50-fb5d-4c0d-ac36-7888f2744f4f/osist-pren-1253-7-2020>

ICS:

91.140.80 Drenažni sistemi Drainage systems

oSIST prEN 1253-7:2020

en,fr,de

iTeh STANDARD PREVIEW
(standards.iteh.ai)

[oSIST prEN 1253-7:2020](#)

<https://standards.iteh.ai/catalog/standards/sist/f8929c50-fb5d-4c0d-ac36-7888f2744f4f/osist-pren-1253-7-2020>

EUROPEAN STANDARD
NORME EUROPÉENNE
EUROPÄISCHE NORM

DRAFT
prEN 1253-7

July 2020

ICS 91.140.80

English Version

Gullies for buildings - Part 7: Trapped floor gullies with mechanical closure

Avaloirs et siphons pour bâtiments - Partie 7: Siphons de sol avec système d'obturation mécanique

Abläufe für Gebäude - Teil 7: Bodenabläufe mit mechanischem Geruchverschluss

This draft European Standard is submitted to CEN members for enquiry. It has been drawn up by the Technical Committee CEN/TC 165.

If this draft becomes a European Standard, CEN members are bound to comply with the CEN/CENELEC Internal Regulations which stipulate the conditions for giving this European Standard the status of a national standard without any alteration.

This draft European Standard was established by CEN in three official versions (English, French, German). A version in any other language made by translation under the responsibility of a CEN member into its own language and notified to the CEN-CENELEC Management Centre has the same status as the official versions.

CEN members are the national standards bodies of Austria, Belgium, Bulgaria, Croatia, Cyprus, Czech Republic, Denmark, Estonia, Finland, France, Germany, Greece, Hungary, Iceland, Ireland, Italy, Latvia, Lithuania, Luxembourg, Malta, Netherlands, Norway, Poland, Portugal, Republic of North Macedonia, Romania, Serbia, Slovakia, Slovenia, Spain, Sweden, Switzerland, Turkey and United Kingdom.

<https://standards.iteh.ai/catalog/standards/sist/f8929c50-fb5d-4c0d-ac36-7888f274481f/osist-pr-en-1253-7-2020>

Recipients of this draft are invited to submit, with their comments, notification of any relevant patent rights of which they are aware and to provide supporting documentation.

Warning : This document is not a European Standard. It is distributed for review and comments. It is subject to change without notice and shall not be referred to as a European Standard.



EUROPEAN COMMITTEE FOR STANDARDIZATION
COMITÉ EUROPÉEN DE NORMALISATION
EUROPÄISCHES KOMITEE FÜR NORMUNG

CEN-CENELEC Management Centre: Rue de la Science 23, B-1040 Brussels

Contents	Page
European foreword.....	3
1 Scope	4
2 Normative references	4
3 Terms and definitions	4
4 Design and construction	8
4.1 General.....	8
4.2 Appearance.....	8
4.3 Apertures in gratings.....	8
4.4 Resistance to pressure	9
4.4.1 Requirements	9
4.4.2 Test method	9
4.5 Blockage prevention	10
4.5.1 Access for cleaning.....	10
4.5.2 Anti-blockage (clogging test)	11
4.6 Places of installation	13
4.6.1 General.....	13
4.6.2 Exceptions.....	13
4.7 Materials.....	13
4.8 Thermal behavior of floor gullies.....	13
4.8.1 General.....	13
4.8.2 Requirements	13
4.8.3 Test method	13
4.8.4 Additional test for floor gullies for use with sheet floor coverings and liquid applied membranes.....	14
4.9 Tightness.....	15
4.9.1 Odour-tightness	15
4.9.2 Watertightness of bodies.....	16
4.9.3 Watertightness of extensions	16
4.10 Mechanical strength.....	16
4.10.1 Loading strength.....	16
4.10.2 Clamping ring strength	19
4.10.3 Additional mechanical strength according to the installation	19
4.10.4 Floor gullies for use with liquid applied membranes	23
4.11 Flow rates.....	23
4.11.1 Principle	23
4.11.2 Requirements	23
4.11.3 Test method	24
4.11.4 Test arrangement.....	24
5 Allocation and sequence of tests	25
6 Marking	25
7 Evaluation of conformity	26
Annex A (normative) Sequence of the tests	27
Annex B (normative) Examples of top view of the positioning of shape of test blocks applied on the gratings	28
Annex C (normative) Test solution	30
Bibliography	31

European foreword

This document (prEN 1253-7:2020) has been prepared by Technical Committee CEN/TC 165 “Waste water engineering”, the secretariat of which is held by DIN.

This document is currently submitted to the CEN Enquiry.

Within its program of work, Technical Committee CEN/TC 165 requested CEN/TC 165/WG 11 “Gratings, covers and other ancillary components for use inside buildings” to prepare the following standard:

EN 1253-7, Trapped floor gullies with mechanical closure.

The EN 1253 series under the main title *Gullies for buildings* will actually consist of the following parts:

- *Part 1: Trapped floor gullies with a depth water seal of at least 50 mm;*
- *Part 2: Roof drains and floor gullies without trap;*
- *Part 3: Evaluation of conformity;*
- *Part 4: Access covers;*
- *Part 5: Gullies with light liquids closure;*
- *Part 6: Trapped floor gullies with a depth of water seal less than 50 mm;*
- *Part 7: Trapped floor gullies with mechanical closure;*
- *Part 8: Trapped floor gullies with combined mechanical closure and water seal.*

Since the versions of EN 1253-1 and EN 1253-2, the most significant technical changes are the following:

- a) grouping of “Requirements” and “Test method” articles for a test;
- b) adding Annex B with examples of top view of the positioning of shape of test blocks applied on the gratings;
- c) adding tolerance;
- d) adding a clogging test;

prEN 1253-7:2020 (E)**1 Scope**

This document classifies floor gullies for use inside buildings, gives guidance for places of installation and specifies requirements for the construction, design, performance and marking of factory made gullies for buildings, irrespective of the material, for use in drainage systems requiring a trap with a mechanical closure (referred to as floor gullies).

NOTE Floor gullies with a mechanical closure are not covered by Part 1, Part 6, Part 8.

These products are intended to be installed where:

- the building does not exceed a ground-floor and three floors above;
- infrequent use could result in a water seal evaporating.

2 Normative references

The following documents are referred to in the text in such a way that some or all of their content constitutes requirements of this document. For dated references, only the edition cited applies. For undated references, the latest edition of the referenced document (including any amendments) applies.

EN 124 (all parts), *Gully tops and manhole tops for vehicular and pedestrian areas — Design requirements, type testing, marking, quality control*

EN 476, *General requirements for components used in drains and sewers*

EN 1253-3, *Gullies for buildings — Part 3: Evaluation of conformity*

3 Terms and definitions

For the purposes of this document, the following terms and definitions apply.

ISO and IEC maintain terminological databases for use in standardization at the following addresses:

- ISO Online browsing platform: available at <https://www.iso.org/obp>
- IEC Electropedia: available at <https://www.electropedia.org/>

3.1**trapped floor gully**

discharge fitting the top of which is a grating or cover capable of installation at ground or floor level, intended to receive wastewater either through apertures in the grating and/or channels joined to the body of the gully and to drain that wastewater through the outlet

Note 1 to entry: See Figure 1.

Note 2 to entry: In this document, the term trapped “floor gully” includes linear products, such as channel drains.

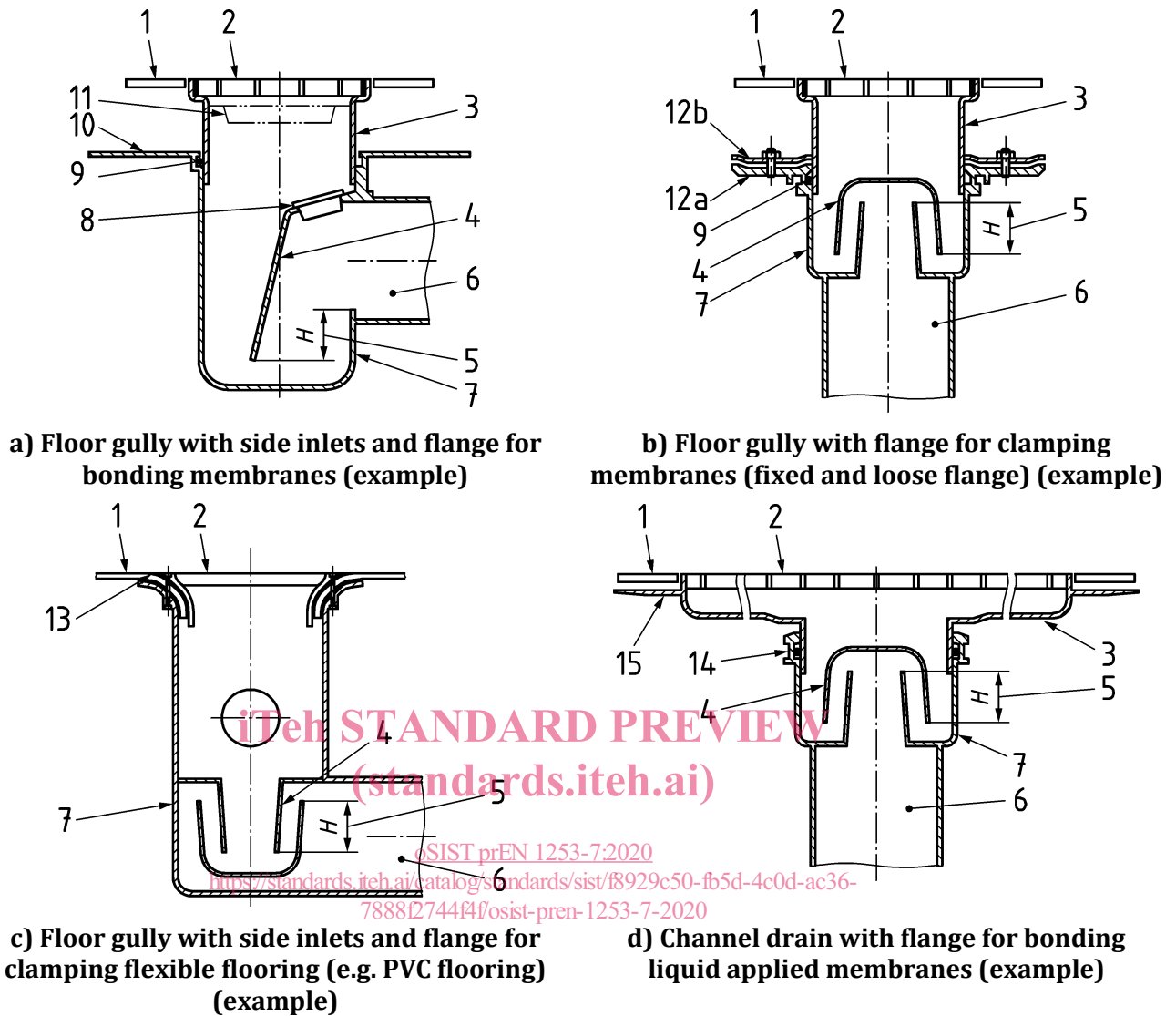

Key

1	finished floor	9	weep hole
2	grating/cover	10	flange for bonding membranes
3	extension	11	sediment bucket
4	trap	12	connecting flange with counter flange
5	depth of water seal ($H \geq 50$ mm)	a	fixed flange
6	outlet	b	loose flange
7	body	13	flange for clamping flexible flooring with a clamping ring
8	access for cleaning	14	seal
		15	flange for bonding liquid applied membrane

Figure 1 — Types of floor gullies

3.2

grating

removable component with apertures which permits the discharge of water

prEN 1253-7:2020 (E)**3.3
frame**

support for a grating or cover which is connected to a body either directly or by means of a membrane clamping ring or an extension

**3.4
cover**

removable part of an access cover which covers the opening

**3.5
body**

part of a floor gully below or in the floor on which the grating/frame/extension is mounted, and to which the pipework is connected

**3.6
extension**

component used to adjust the height of a grating or cover above a body

**3.7
joint**

connection between the adjacent ends of two components including the means of sealing

**3.8
membrane clamping ring**

component used to clamp a membrane or a sheet floor covering to a body or extension

**3.9
connecting flange**

separate or an integral part of a body or of an extension which receives a membrane or sheet floor covering

**3.10
external diameter**

mean external diameter of the pipe barrel at any cross section

**3.11
internal diameter**

mean internal diameter of the pipe barrel at any cross section

**3.12
trap with mechanical closure**

removable part of the body which prevents, by means of mechanical closure system, the passage of foul air from the outlet to the inlet

**3.13
domestic wastewater**

water polluted by the human life, including water discharged from kitchens, laundry rooms, lavatories, bathrooms, toilets and similar facilities

[SOURCE: EN 16323:2014, 2.1.2.3]

3.14**sheet floor covering**

flexible watertight finished layer for floors affixed to the flange by bonding, welding and/or by means of a clamping ring

3.15**membrane**

watertight and damp proof layer attached to the floor gully either in the floor or on the floor

3.16**head of water**

depth h of a water line over the frame of the floor gully

Note 1 to entry: See Figure 2.

Note 2 to entry: For floor gullies without frame, the depth of water line is the lowest level over the finished floor.

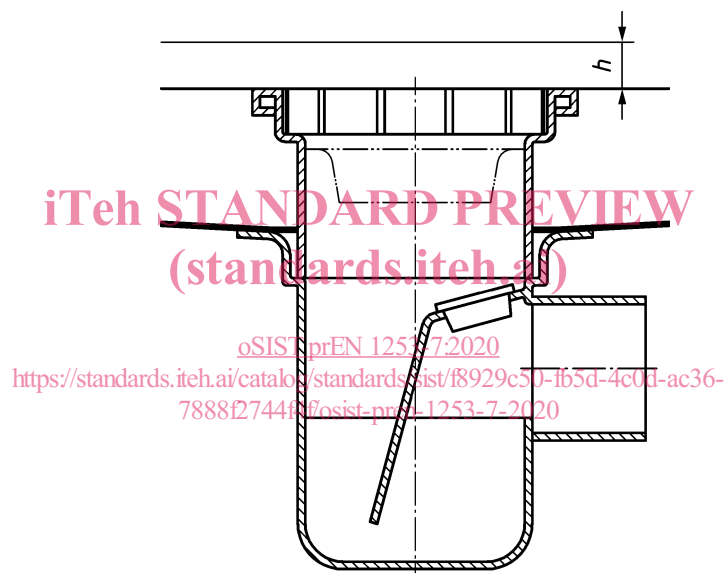
**Key**

h head of water

Figure 2 — Head of water for floor gullies

3.17**outlet**

male or female connection to the discharge pipe

3.18**nominal size****DN**

numerical indication of size which is a convenient integer approximately equal to the internal diameter (DN/ID) or the external diameter (DN/OD) in millimetres

prEN 1253-7:2020 (E)**3.19****clear opening****CO**

diameter of the largest circle that can be inscribed within the unsupported area of the grating

3.20**test load**

specified load which a component is required to withstand

3.21**liquid applied waterproofing kit**

particular combination of a defined set of components to be installed in liquid form for waterproofing by application and/or incorporation and/or joining of the components in accordance with particular design methods

Note 1 to entry: The liquid applied watertight kit is usually a paste-like composite material or a combination of separate materials that can be poured, spread or sprayed on the subsurface by brush, roller or similar suitable applicator.

4 Design and construction**4.1 General**

Floor gullies shall be capable of being connected to the pipework system covered by relevant European Standards, and, when installed in accordance with the manufacturer's instructions, shall form an integral part of the building. There shall be no movement possible between the body and the floor, which would impair the functioning of the installed gully.

In areas where pressure testing of the pipe system is necessary floor gullies for use in the ground floor shall enable such test to be performed.

The upper surfaces of frame and grating shall be flush. When in position, it shall not be possible for gratings and covers to be dislodged from the frame, but they shall be easy to be released for e.g. maintenance and cleaning.

Traps with mechanical closure shall be prevented, by design features such as fixings or weights, from uncontrolled floating or becoming displaced.

Floor gullies and their components shall be resistant to normal actions of mechanical and thermal character.

Floor gullies may be designed without side inlet.

Floor gullies shall be delivered with installation instructions.

All pipe joints to and from the floor gully shall be designed to be watertight in accordance with EN 476.

4.2 Appearance

Internal and external surfaces shall be free from sharp edges and imperfections which could impair functioning of the floor gully or give risk of injury.

4.3 Apertures in gratings

Apertures can be holes or slots of any shape and may also be formed between grating and frame.

By means of suitable measuring instruments or balls of suitable sizes, the dimensions of apertures in grating shall be as specified in Table 1.

Table 1 — Apertures in gratings

Class	Dimensions of apertures in gratings	
	Minimum width	Maximum width
H 1,5	4 ^b	15 (max. 8 mm in barefoot areas)
K 3	4 ^b	0 (max. 8 mm in barefoot areas)
L 15 ^a	4	15 (max. 8 mm in barefoot areas)

^a In commercially used premises, gratings may also be used with a maximum width of apertures up to 31 mm.

^b Apertures of less than 4 mm width are permitted but shall not form part of the hydraulic tests.

4.4 Resistance to pressure

4.4.1 Requirements

The applied pressure shall be +400 Pa.

4.4.2 Test method

Mount the floor gully in a test arrangement as illustrated in Figure 3, and run water through the gully.

Close the flap by means of the bypass valves and slowly increase negative pressure until the mechanical closure opens. Note the pressure.

Air coming in at negative pressure is not a condition of failure.

Open the flap and run water through the gully.

Apply to the outlet side a positive pressure 400 Pa (−0/+10 %) constant over a period of at least 15 min.

The pressure may not drop beyond 90 % of the starting pressure.

Interrupt the test if the pressure cannot be reached or has not stabilized within 2 min (test failed).

Verify that the mechanical closure system remains in place.

With the flap closed, set the desired negative pressure with the bypass valves, and read the manometer. The sensors in the floor gully are connected to the recording device. When the flap is closed rapidly, the desired vacuum pressure is established immediately.

By reversing the fan and securing the flap in the closed position, the arrangement can be used also for the measurement of the resistance to positive pressure.

prEN 1253-7:2020 (E)

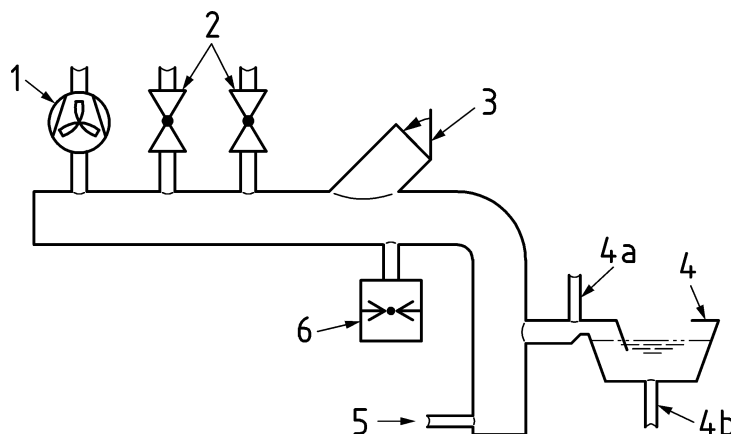
**Key**

- 1 fan
- 2 bypass valves
- 3 flap
- 4 water seal
- 4a connection to pressure recorder
- 4b connection to water level recorder
- 5 drain cock
- 6 pressure measuring device (manometer)

iTech STANDARD PREVIEW
(standards.iteh.ai)

Figure 3 — Typical test arrangement for determining the resistance of water seals to pressure

4.5 Blockage prevention

oSIST prEN 1253-7:2020

4.5.1 Access for cleaning

<https://standards.iteh.ai/catalog/standards/sist/f8929c50-fb5d-4c0d-ac36-7888f2744f4f/osist-pren-1253-7-2020>

4.5.1.1 General

Floor gullies should have provision for mechanical cleaning of the outlet pipe systems leading to and from the gully.

Any opening provided for mechanical cleaning shall be tested in accordance with 4.5.1.3.

4.5.1.2 Requirements

When an opening with an airtight and watertight cover or plug is provided, the clear diameter of such opening shall be as specified in Table 2.

Table 2 — Access for cleaning

DN	Dimensions of access for cleaning (mm)
DN ≤ 110	∅ > 32
125 ≤ DN ≤ 200	∅ > 50

4.5.1.3 Test method

Demount and remount those parts of the floor gully which are designed for cleaning access to the floor gully itself and/or to the pipework to which it is connected.