



SLOVENSKI STANDARD
oSIST prEN 12163:2022
01-oktober-2022

Baker in bakrove zlitine - Palice za splošno uporabo

Copper and copper alloys - Rod for general purposes

Kupfer und Kupferlegierungen - Stangen zur allgemeinen Verwendung

Cuivre et alliages de cuivre - Barres pour usages généraux

Ta slovenski standard je istoveten z: prEN 12163

<https://standards.iteh.ai/catalog/standards/sist/ceb1f0b5-86e3-4ecd-8ecf-3834f2e030c2/osist-pren-12163-2022>

ICS:

77.150.30 Bakreni izdelki Copper products

oSIST prEN 12163:2022

en,fr,de

EUROPEAN STANDARD
NORME EUROPÉENNE
EUROPÄISCHE NORM

DRAFT
prEN 12163

August 2022

ICS 77.150.30

Will supersede EN 12163:2016

English Version

Copper and copper alloys - Rod for general purposes

Cuivre et alliages de cuivre - Barres pour usages
généraux

Kupfer und Kupferlegierungen - Stangen zur
allgemeinen Verwendung

This draft European Standard is submitted to CEN members for enquiry. It has been drawn up by the Technical Committee CEN/TC 133.

If this draft becomes a European Standard, CEN members are bound to comply with the CEN/CENELEC Internal Regulations which stipulate the conditions for giving this European Standard the status of a national standard without any alteration.

This draft European Standard was established by CEN in three official versions (English, French, German). A version in any other language made by translation under the responsibility of a CEN member into its own language and notified to the CEN-CENELEC Management Centre has the same status as the official versions.

CEN members are the national standards bodies of Austria, Belgium, Bulgaria, Croatia, Cyprus, Czech Republic, Denmark, Estonia, Finland, France, Germany, Greece, Hungary, Iceland, Ireland, Italy, Latvia, Lithuania, Luxembourg, Malta, Netherlands, Norway, Poland, Portugal, Republic of North Macedonia, Romania, Serbia, Slovakia, Slovenia, Spain, Sweden, Switzerland, Turkey and United Kingdom.

Recipients of this draft are invited to submit, with their comments, notification of any relevant patent rights of which they are aware and to provide supporting documentation.

Warning : This document is not a European Standard. It is distributed for review and comments. It is subject to change without notice and shall not be referred to as a European Standard.



EUROPEAN COMMITTEE FOR STANDARDIZATION
COMITÉ EUROPÉEN DE NORMALISATION
EUROPÄISCHES KOMITEE FÜR NORMUNG

CEN-CENELEC Management Centre: Rue de la Science 23, B-1040 Brussels

Contents	Page
European foreword.....	4
Introduction	5
1 Scope	6
2 Normative references.....	6
3 Terms and definitions	6
4 Designations.....	7
4.1 Material.....	7
4.1.1 General.....	7
4.1.2 Symbol.....	7
4.1.3 Number	7
4.2 Material condition	7
4.3 Product.....	8
5 Ordering information	10
6 Requirements.....	11
6.1 Composition	11
6.2 Mechanical properties.....	11
6.3 Resistance to dezincification	11
6.4 Residual stress level.....	11
6.5 Dimensions and tolerances	12
6.5.1 Diameter or width across-flats.....	12
6.5.2 Shape tolerances	12
6.5.3 Straightness.....	12
6.5.4 Length.....	12
6.5.5 Corner radii.....	12
6.5.6 Twist of polygonal rod.....	13
6.6 Surface quality.....	13
6.7 Internal inclusion.....	13
7 Sampling.....	13
7.1 General.....	13
7.2 Analysis.....	13
7.3 Mechanical tests	14
7.4 Dezincification resistance and stress corrosion resistance test.....	14
8 Test methods	14
8.1 Analysis.....	14
8.2 Tensile test	14
8.2.1 General.....	14
8.2.2 Location of test pieces	14
8.2.3 Shape and size of test pieces	15
8.2.4 Procedure for testing.....	15
8.2.5 Determination of results	15
8.3 Hardness test.....	15

8.4	Dezincification resistance test.....	15
8.5	Stress corrosion resistance test	15
8.6	Determination of the electrical conductivity	16
8.7	Retests	16
8.7.1	Analysis, tensile, hardness and dezincification resistance tests and determination of the electrical conductivity	16
8.7.2	Stress corrosion resistance test	16
8.8	Rounding of results.....	16
9	Declaration of conformity and inspection documentation	17
9.1	Declaration of conformity	17
9.2	Inspection documentation	17
10	Marking, packaging, labelling	17
Annex ZA (informative) Relationship between this European Standard and the essential requirements of Directive 2014/68/EU (Pressure equipment Directive) aimed to be covered.....		43
Bibliography		44

iTeh STANDARD PREVIEW (standards.iteh.ai)

[oSIST prEN 12163:2022](https://standards.iteh.ai/catalog/standards/sist/ceb1f0b5-86c3-4ecd-8ecf-3834f2e030c2/osist-pren-12163-2022)

<https://standards.iteh.ai/catalog/standards/sist/ceb1f0b5-86c3-4ecd-8ecf-3834f2e030c2/osist-pren-12163-2022>

European foreword

This document (prEN 12163:2022) has been prepared by Technical Committee CEN/TC 133 “Copper and copper alloys”, the secretariat of which is held by DIN.

This document is currently submitted to the CEN Enquiry.

This document will supersede EN 12163:2016.

In comparison with EN 12163:2016, the following significant technical changes were made:

- a) Introduction of 6.7 Internal inclusion;
- b) Modified the definition of diameter or width across-flats at 6.5.1;
- c) Added a new Figure for straightness at 6.5.3 and modified values in Table 18
- d) CuZn4Si4MnP (CW245E) and CuZn9Si4MnP (CW246E) added in the new Table 2 and new Table 10
- e) CuSn5 (CW451K) added in Table 6 and Table 14;
- f) Introduction in the chemical composition Tables of a footnote to explain the meaning of elements for which no upper and lower limits are defined;
- g) Annex ZA added.

This document is one of a series of European Standards for the copper and copper alloy products rod, wire, profile and forgings. Other products are specified as follows:

- EN 12164, *Copper and copper alloys — Rod for free machining purposes*;
- EN 12165, *Copper and copper alloys — Wrought and unwrought forging stock*;
- EN 12166, *Copper and copper alloys — Wire for general purposes*;
- EN 12167, *Copper and copper alloys — Profiles and bars for general purposes*;
- EN 12168, *Copper and copper alloys — Hollow rod for free machining purposes*;
- EN 13601, *Copper and copper alloys — Copper rod, bar and wire for general electrical purposes*;
- EN 13602, *Copper and copper alloys — Drawn, round copper wire for the manufacture of electrical conductors*;
- EN 13605, *Copper and copper alloys — Copper profiles and profiled wire for electrical purposes*.

This document has been prepared under a Standardization Request given to CEN by the European Commission and the European Free Trade Association, and supports essential requirements of EU Directive(s) / Regulation(s).

For relationship with EU Directive(s) / Regulation(s), see informative Annex ZA, which is an integral part of this document.

Introduction

The European Committee for Standardization (CEN) draws attention to the fact that it is claimed that compliance with this document may involve the use of a patent concerning the alloys CuZn4Si4MnP (CW245E) and CuZn9Si4MnP (CW246E) given in 6.1.

CEN takes no position concerning the evidence, validity and scope of this patent right.

The holder of this patent right has ensured the CEN that he is willing to negotiate licenses either free of charge or under reasonable and non-discriminatory terms and conditions with applicants throughout the world. In this respect, the statement of the holder of this patent right is registered with CEN. Information may be obtained from:

Viega Technology GmbH and Co. KG
Viega Platz 1
57439 Attendorn
GERMANY

Attention is drawn to the possibility that some of the elements of this document may be the subject of patent rights other than those identified above. CEN shall not be held responsible for identifying any or all such patent rights.

CEN and CENELEC maintain online lists of patents relevant to their standards. Users are encouraged to consult the lists for the most up to date information concerning patents (<ftp://ftp.cencenelec.eu/EN/IPR/Patents/IPRdeclaration.pdf>).

Due to developing legislation, the composition of a material may be restricted to the composition specified in this European Standard with respect to individual uses (e.g. for the use in contact with drinking water in some Member States of the European Union). These individual restrictions are not part of this European Standard. Nevertheless, for materials for which traditional and major uses are affected, these restrictions are indicated. The absence of an indication, however, does not imply that the material can be used in any application without any legal restriction.

eb1f0b5-86c3-4ecd-8ecf-3834f2e030c2/osist-pren-12163-2022

1 Scope

This document specifies the composition, property requirements and dimensional tolerances for copper alloy rod in the shape of circles, squares, hexagons or octagons, finally produced by drawing or extruding intended for general purposes.

The sampling procedures and the methods of test for verification of conformity to the requirements of this document are also specified.

2 Normative references

The following documents are referred to in the text in such a way that some or all of their content constitutes requirements of this document. For dated references, only the edition cited applies. For undated references, the latest edition of the referenced document (including any amendments) applies.

EN 764-5:2014, *Pressure equipment - Part 5: Inspection documentation of metallic materials and compliance with the material specification*

EN 1173:2008, *Copper and copper alloys - Material condition designation*

EN 1412:2016, *Copper and copper alloys - European numbering system*

EN 10204:2004, *Metallic products - Types of inspection documents*

EN 14977:2006, *Copper and copper alloys - Detection of tensile stress - 5 % ammonia test*

EN ISO 6506-1:2014, *Metallic materials - Brinell hardness test - Part 1: Test method (ISO 6506-1:2014)*

EN ISO 6509-1:2014, *Corrosion of metals and alloys - Determination of dezincification resistance of copper alloys with zinc - Part 1: Test method (ISO 6509-1:2014)*

EN ISO 6892-1:2019, *Metallic materials - Tensile testing - Part 1: Method of test at room temperature (ISO 6892-1:2019)*

ISO 1190-1:1982, *Copper and copper alloys — Code of designation — Part 1: Designation of materials*

ISO 6957:1988, *Copper alloys — Ammonia test for stress corrosion resistance*

3 Terms and definitions

For the purposes of this document, the following terms and definitions apply.

ISO and IEC maintain terminological databases for use in standardization at the following addresses:

- IEC Electropedia: available at <http://www.electropedia.org/>
- ISO Online browsing platform: available at <http://www.iso.org/obp>

3.1

rod

straight product of uniform cross-section along its whole length

3.2

deviation from circular form

difference between the maximum and the minimum diameters measured at any one cross-section of a round product

4 Designations

4.1 Material

4.1.1 General

The material is designated either by symbol or by number (see Tables 1 to 8).

4.1.2 Symbol

The material symbol designation is based on the designation system given in ISO 1190-1:1982.

NOTE Although material symbol designations used in this standard might be the same as those in other standards using the designation system given in ISO 1190-1:1982, the detailed composition requirements are not necessarily the same.

4.1.3 Number

The material number designation is in accordance with the system given in EN 1412:2016.

4.2 Material condition

For the purposes of this document, the following designations, which are in accordance with the system given in EN 1173:2008, apply for the material condition:

- | | |
|------------|--|
| M | Material condition for the product as manufactured without specified mechanical properties; |
| R... | Material condition designated by the minimum value of tensile strength requirement for the product with mandatory tensile property requirements; |
| Y... | Material condition designated by the minimum value of yield strength requirement for the product with mandatory tensile property requirements; |
| H... | Material condition designated by the minimum value of hardness requirement for the product with mandatory hardness requirements; |
| S (suffix) | Material condition for a product which is stress relieved. |

Products in the M, R... or H... material condition may be specially processed (i.e. mechanically or thermally stress relieved) in order to lower the residual stress level to improve the resistance to stress corrosion and the dimensional stability on machining [see Clause 5 list entry l), list entry m) and 8.4].

Exact conversion between material conditions designated R... and H... is not possible.

Except when the suffix S is used, material condition is designated by only one of the above designations.

prEN 12163:2022 (E)**4.3 Product**

The product designation provides a standardized pattern of designation from which a rapid and unequivocal description of a product is conveyed in communication. It provides mutual comprehension at the international level with regard to products which meet the requirements of the relevant European Standard.

The product designation is no substitute for the full content of the standard.

The product designation for products to this standard shall consist of:

- denomination (Rod);
- number of this document (EN 12163);
- material designation, either symbol or number (see Tables 1 to 8);
- DW for compliance in the chemical composition according to the 4 MS Common Composition List. This information is mandatory in the case in which the product is used for drinking water applications according to the 4 MS Common Composition List and not to be given in other cases;
- material condition designation (see Tables 9 to 16);
- cross-sectional shape (the following designations shall be used, as appropriate: RND for round, SQR for square, HEX for hexagonal, OCT for octagonal);
- nominal cross-sectional dimension (diameter or width across-flats);
- tolerance class (see Table 17);
- for polygonal rod, the corner shape (the following designations shall be used as appropriate: SH for sharp, RD for rounded), (see Table 19).

The derivation of a product designation is shown in the following examples.

EXAMPLE 1 Rod for general purposes conforming to this standard, in material designated either CuZn40 or CW509L, for standard applications, in material condition R410, hexagonal, nominal width across-flats 14 mm, tolerance Class B, rounded corners, will be designated as follows:

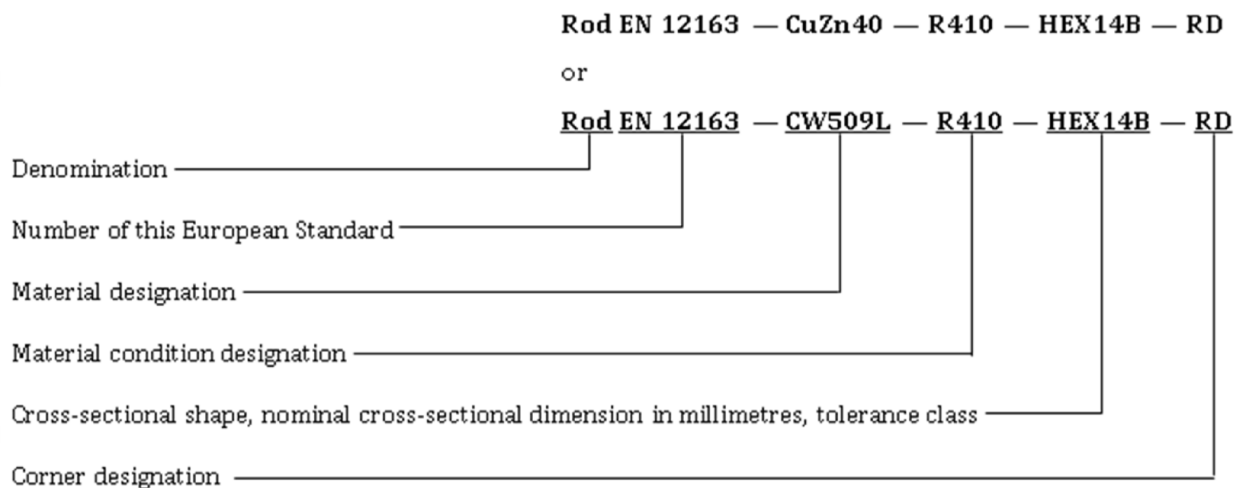

EXAMPLE 2 Rod for general purposes conforming to this standard, in material designated either CuZn40 or CW509L, for drinking water applications according to the 4 MS Common Composition List, in material condition R410, hexagonal, nominal width across-flats 14 mm, tolerance Class B, rounded corners, will be designated as follows:

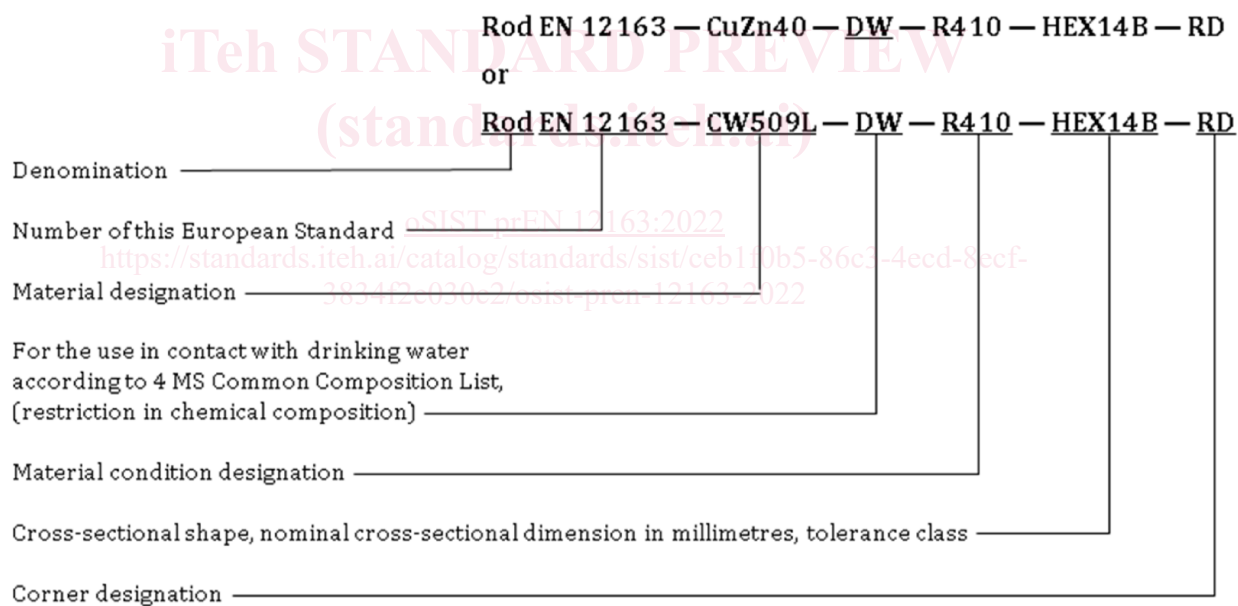

5 Ordering information

In order to facilitate the enquiry, order and confirmation of order procedures between the purchaser and the supplier, the purchaser shall state on his enquiry and order the following information:

- a) mass of product required;
- b) denomination (Rod);
- c) number of this document (EN 12163);
- d) material designation (see Tables 1 to 8);
- e) material condition designation (see 4.2 and Tables 9 to 16) if it is other than M;
- f) DW for compliance in the chemical composition according to the 4 MS Common Composition List. This information is mandatory in the case in which the product is used for drinking water applications according to the 4 MS Common Composition List and not to be given in other cases;
- g) cross-sectional shape;
- h) nominal cross-sectional dimension (diameter or width across-flats);
- i) whether other than class A tolerances are required (see Table 17);
- j) for polygonal rod: whether “sharp” or “rounded” corners are required unless the corner radii shall be left to the discretion of the supplier (see 6.5.5 and Table 19);
- k) length and length tolerance (see 6.5.4).

It is recommended that the product designation, as described in 4.3, is used for items b) to k).

In addition, the purchaser shall also state on the enquiry and order any or the following, if required:

- l) whether the products are required to pass a stress corrosion resistance test. If so, which test method shall be used (see 8.5) if the choice is not to be left to the discretion of the supplier;
- m) whether the products shall be supplied in a thermally stress relieved material condition;
- n) whether special surface quality is required (see 6.6);
- o) whether a declaration of conformity is required (see 9.1);
- p) whether an inspection document is required, and if so, which type (see 9.2);
- q) whether there are any special requirements for marking, packaging or labelling (see Clause 10).

EXAMPLE Ordering details for 500 kg rod for general purposes conforming to EN 12163, in material designated either CuZn40 or CW509L, for drinking water application according to the 4 MS Common Composition List, in material condition R410, hexagonal, nominal width across-flats 14 mm, tolerance class B, rounded corners, length 3 000 mm \pm 100 mm:

500 kg Rod EN 12163 — CuZn40 — DW — R410 — HEX14B — RD
— length 3 000 mm \pm 100 mm

or

500 kg Rod EN 12163 — CW509L — DW — R410 — HEX14B — RD
— length 3 000 mm \pm 100 mm

6 Requirements

6.1 Composition

The composition shall conform to the requirements for the appropriate material given in Tables 1 to 8.

Due to developing legislation, specific applications (see 4.3) may require restrictions in the chemical composition. In this case the limitations shall be specified in the ordering information [see Clause 5, list entry f)].

6.2 Mechanical properties

The tensile or the hardness properties shall conform to the appropriate requirements given in Tables 9 to 16. The tests shall be carried out in accordance with 8.2 or 8.3.

6.3 Resistance to dezincification

This requirement only applies to materials that are declared resistant to dezincification.

The maximum depth of dezincification, in any direction, of CuZn38As (CW511L) and CuZn21Si3P (CW724R)) products shall be 100 μ m.

The test shall be carried out in accordance with 8.4.

NOTE Shape and distribution of beta phase aggregates can influence the dezincification resistance of products. Special requirements relating to shape and distribution of β phase aggregates are subject to agreement between purchaser and supplier.

Products in alloy CuZn38As (CW511L) may be subjected to heat treatment in the range 500 °C to 550 °C during manufacture. If the user needs to heat the material out of the range before specified (i.e. soldering, brazing or welding operations) above then advice should be sought from the supplier.

6.4 Residual stress level

Products ordered and supplied in the stress relieved condition (see 4.2, 2nd paragraph) shall show no evidence of cracking if tested. The tests shall be carried out in accordance with 8.5.