



SLOVENSKI STANDARD
SIST EN 12163:2024

01-december-2024

Baker in bakrove zlitine - Palice za splošno uporabo

Copper and copper alloys - Rod for general purposes

Kupfer und Kupferlegierungen - Stangen zur allgemeinen Verwendung

Cuivre et alliages de cuivre - Barres pour usages généraux

Ta slovenski standard je istoveten z: EN 12163:2024

ICS:

77.150.30 Bakreni izdelki [SIST EN 12163:2024](https://standards.iteh.ai/SIST/EN/12163/2024) Copper products [3834f2e030c2/sist-en-12163-2024](https://standards.iteh.ai/SIST/EN/12163/2024)

SIST EN 12163:2024

en,fr,de

EUROPEAN STANDARD

EN 12163

NORME EUROPÉENNE

EUROPÄISCHE NORM

October 2024

ICS 77.150.30

Supersedes EN 12163:2016

English Version

Copper and copper alloys - Rod for general purposes

Cuiivre et alliages de cuivre - Barres pour usages
générauxKupfer und Kupferlegierungen - Stangen zur
allgemeinen Verwendung

This European Standard was approved by CEN on 30 June 2024.

CEN members are bound to comply with the CEN/CENELEC Internal Regulations which stipulate the conditions for giving this European Standard the status of a national standard without any alteration. Up-to-date lists and bibliographical references concerning such national standards may be obtained on application to the CEN-CENELEC Management Centre or to any CEN member.

This European Standard exists in three official versions (English, French, German). A version in any other language made by translation under the responsibility of a CEN member into its own language and notified to the CEN-CENELEC Management Centre has the same status as the official versions.

CEN members are the national standards bodies of Austria, Belgium, Bulgaria, Croatia, Cyprus, Czech Republic, Denmark, Estonia, Finland, France, Germany, Greece, Hungary, Iceland, Ireland, Italy, Latvia, Lithuania, Luxembourg, Malta, Netherlands, Norway, Poland, Portugal, Republic of North Macedonia, Romania, Serbia, Slovakia, Slovenia, Spain, Sweden, Switzerland, Türkiye and United Kingdom.

iteh Standards
Document Preview

[SIST EN 12163:2024](https://standards.iteh.ai/catalog/standards/sist/ceb1f0b5-86c3-4ecd-8ecf-3834f2e030c2/sist-en-12163-2024)

<https://standards.iteh.ai/catalog/standards/sist/ceb1f0b5-86c3-4ecd-8ecf-3834f2e030c2/sist-en-12163-2024>



EUROPEAN COMMITTEE FOR STANDARDIZATION
COMITÉ EUROPÉEN DE NORMALISATION
EUROPÄISCHES KOMITEE FÜR NORMUNG

CEN-CENELEC Management Centre: Rue de la Science 23, B-1040 Brussels

Contents	Page
European foreword.....	4
Introduction	6
1 Scope	7
2 Normative references.....	7
3 Terms and definitions	7
4 Designations.....	8
4.1 Material.....	8
4.1.1 General.....	8
4.1.2 Symbol.....	8
4.1.3 Number	8
4.2 Material condition	8
4.3 Product.....	8
5 Ordering information	10
6 Requirements	12
6.1 Composition	12
6.2 Mechanical properties.....	12
6.3 Resistance to dezincification	12
6.4 Residual stress level.....	12
6.5 Dimensions and tolerances	12
6.5.1 Diameter or width across-flats.....	12
6.5.2 Shape tolerances	12
6.5.3 Straightness.....	12
6.5.4 Length.....	13
6.5.5 Corner radii.....	13
6.5.6 Twist of polygonal rod.....	13
6.6 Surface quality.....	14
6.7 Internal inclusion.....	14
7 Sampling.....	14
7.1 General.....	14
7.2 Analysis.....	14
7.3 Mechanical tests	14
7.4 Dezincification resistance and stress corrosion resistance test.....	14
8 Test methods	15
8.1 Analysis.....	15
8.2 Tensile test	15
8.2.1 General.....	15
8.2.2 Location of test pieces	15
8.2.3 Shape and size of test pieces	15
8.2.4 Procedure for testing.....	15
8.2.5 Determination of results	15
8.3 Hardness test.....	16
8.4 Dezincification resistance test	16

8.5	Stress corrosion resistance test	16
8.6	Determination of the electrical conductivity	16
8.7	Retests	16
8.7.1	Analysis, tensile, hardness and dezincification resistance tests and determination of the electrical conductivity	16
8.7.2	Stress corrosion resistance test	17
8.8	Rounding of results	17
9	Certificate of compliance and inspection documentation	17
9.1	Certificate of compliance	17
9.2	Inspection documentation	17
10	Marking, packaging, labelling	17
Annex ZA (informative) Relationship between this European Standard and the essential requirements of Directive 2014/68/EU (Pressure equipment Directive) aimed to be covered		43
Bibliography		44

iTech Standards
(<https://standards.iteh.ai>)
Document Preview

[SIST EN 12163:2024](#)

<https://standards.iteh.ai/catalog/standards/sist/ceb1f0b5-86c3-4ecd-8ecf-3834f2e030c2/sist-en-12163-2024>

EN 12163:2024 (E)**European foreword**

This document (EN 12163:2024) has been prepared by Technical Committee CEN/TC 133 “Copper and copper alloys”, the secretariat of which is held by DIN.

This European Standard shall be given the status of a national standard, either by publication of an identical text or by endorsement, at the latest by April 2025, and conflicting national standards shall be withdrawn at the latest by April 2025.

Attention is drawn to the possibility that some of the elements of this document may be the subject of patent rights. CEN shall not be held responsible for identifying any or all such patent rights.

This document supersedes EN 12163:2016.

In comparison with EN 12163:2016, the following significant technical changes were made:

- a) Introduction of 6.7 Internal inclusion;
- b) Modified the definition of diameter or width across-flats at 6.5.1;
- c) Added a new Figure for straightness at 6.5.3 and modified values in Table 18
- d) CuSi4Zn4MnP (CW245E) and CuSi4Zn9MnP (CW246E) added in the new Table 2 and new Table 10
- e) CuSn5 (CW451K) added in Table 6 and Table 14;
- f) Introduction in the chemical composition Tables of a footnote to explain the meaning of elements for which no upper and lower limits are specified;
- g) Annex ZA added.

This document is one of a series of European Standards for the copper and copper alloy products rod, wire, profile and forgings. Other products are specified as follows:

- EN 12164, *Copper and copper alloys — Rod for free machining purposes*;
- EN 12165, *Copper and copper alloys — Wrought and unwrought forging stock*;
- EN 12166, *Copper and copper alloys — Wire for general purposes*;
- EN 12167, *Copper and copper alloys — Profiles and bars for general purposes*;
- EN 12168, *Copper and copper alloys — Hollow rod for free machining purposes*;
- EN 13601, *Copper and copper alloys — Copper rod, bar and wire for general electrical purposes*;
- EN 13602, *Copper and copper alloys — Drawn, round copper wire for the manufacture of electrical conductors*;
- EN 13605, *Copper and copper alloys — Copper profiles and profiled wire for electrical purposes*.

This document has been prepared under a standardization request addressed to CEN by the European Commission. The Standing Committee of the EFTA States subsequently approves these requests for its Member States.

For the relationship with EU Legislation, see informative Annex ZA, which is an integral part of this document.

Any feedback and questions on this document should be directed to the users' national standards body. A complete listing of these bodies can be found on the CEN website.

According to the CEN-CENELEC Internal Regulations, the national standards organisations of the following countries are bound to implement this European Standard: Austria, Belgium, Bulgaria, Croatia, Cyprus, Czech Republic, Denmark, Estonia, Finland, France, Germany, Greece, Hungary, Iceland, Ireland, Italy, Latvia, Lithuania, Luxembourg, Malta, Netherlands, Norway, Poland, Portugal, Republic of North Macedonia, Romania, Serbia, Slovakia, Slovenia, Spain, Sweden, Switzerland, Türkiye and the United Kingdom.

iTeh Standards
(<https://standards.itih.ai>)
Document Preview

[SIST EN 12163:2024](#)

<https://standards.itih.ai/catalog/standards/sist/ceb1f0b5-86c3-4ecd-8ecf-3834f2e030c2/sist-en-12163-2024>

EN 12163:2024 (E)**Introduction**

The European Committee for Standardization (CEN) draws attention to the fact that it is claimed that compliance with this document may involve the use of a patent concerning the alloys CuSi4Zn4MnP (CW245E) and CuSi4Zn9MnP (CW246E) given in 6.1.

CEN takes no position concerning the evidence, validity and scope of this patent right.

The holder of this patent right has ensured the CEN that he is willing to negotiate licenses either free of charge or under reasonable and non-discriminatory terms and conditions with applicants throughout the world. In this respect, the statement of the holder of this patent right is registered with CEN. Information may be obtained from:

Viega Technology GmbH and Co. KG
Viega Platz 1
57439 Attendorn
GERMANY

Attention is drawn to the possibility that some of the elements of this document may be the subject of patent rights other than those identified above. CEN shall not be held responsible for identifying any or all such patent rights.

CEN and CENELEC maintain online lists of patents relevant to their standards. Users are encouraged to consult the lists for the most up to date information concerning patents (<https://www.cencenelec.eu/european-standardization/ipr-and-patents/patents/>).

Due to developing legislation, the composition of a material may be restricted to the composition specified in this European Standard with respect to individual uses (e.g. for the use in contact with drinking water in some Member States of the European Union). These individual restrictions are not part of this European Standard. Nevertheless, for materials for which traditional and major uses are affected, these restrictions are indicated. The absence of an indication, however, does not imply that the material can be used in any application without any legal restriction.

[SIST EN 12163:2024](https://standards.iteh.ai/catalog/standards/sist/ceb1f0b5-86c3-4ecd-8ecf-3834f2e030c2/sist-en-12163-2024)

<https://standards.iteh.ai/catalog/standards/sist/ceb1f0b5-86c3-4ecd-8ecf-3834f2e030c2/sist-en-12163-2024>

1 Scope

This document specifies the composition, property requirements and dimensional tolerances for copper alloy rod in the shape of circles, squares, hexagons or octagons, finally produced by drawing or extruding intended for general purposes.

The sampling procedures and the methods of test for verification of conformity to the requirements of this document are also specified.

2 Normative references

The following documents are referred to in the text in such a way that some or all of their content constitutes requirements of this document. For dated references, only the edition cited applies. For undated references, the latest edition of the referenced document (including any amendments) applies.

EN 764-5:2014, *Pressure equipment - Part 5: Inspection documentation of metallic materials and compliance with the material specification*

EN 1173:2008, *Copper and copper alloys - Material condition designation*

EN 1412:2016, *Copper and copper alloys - European numbering system*

EN 10204:2004, *Metallic products - Types of inspection documents*

EN 14977:2006, *Copper and copper alloys - Detection of tensile stress - 5 % ammonia test*

EN ISO 6506-1:2014, *Metallic materials - Brinell hardness test - Part 1: Test method (ISO 6506-1:2014)*

EN ISO 6509-1:2014, *Corrosion of metals and alloys - Determination of dezincification resistance of copper alloys with zinc - Part 1: Test method (ISO 6509-1:2014)*

EN ISO 6892-1:2019, *Metallic materials - Tensile testing - Part 1: Method of test at room temperature (ISO 6892-1:2019)*

ISO 1190-1:1982, *Copper and copper alloys — Code of designation — Part 1: Designation of materials*

ISO 6957:1988, *Copper alloys — Ammonia test for stress corrosion resistance*

3 Terms and definitions

For the purposes of this document, the following terms and definitions apply.

ISO and IEC maintain terminology databases for use in standardization at the following addresses:

- IEC Electropedia: available at <http://www.electropedia.org/>
- ISO Online browsing platform: available at <http://www.iso.org/obp>

3.1

rod

straight product of uniform cross-section along its whole length

3.2

deviation from circular form

difference between the maximum and the minimum diameters measured at any one cross-section of a round product

EN 12163:2024 (E)**4 Designations****4.1 Material****4.1.1 General**

The material is designated either by symbol or by number (see Tables 1 to 8).

4.1.2 Symbol

The material symbol designation shall be based on the designation system given in ISO 1190-1:1982.

NOTE Although material symbol designations used in this standard might be the same as those in other standards using the designation system given in ISO 1190-1:1982, the detailed composition requirements are not necessarily the same.

4.1.3 Number

The material number designation shall be in accordance with the system given in EN 1412:2016.

4.2 Material condition

For the purposes of this document, the following designations, which are in accordance with the system given in EN 1173:2008, apply for the material condition:

M	Material condition for the product as manufactured without specified mechanical properties;
R...	Material condition designated by the minimum value of tensile strength requirement for the product with mandatory tensile property requirements;
Y...	Material condition designated by the minimum value of yield strength requirement for the product with mandatory tensile property requirements;
H...	Material condition designated by the minimum value of hardness requirement for the product with mandatory hardness requirements;
S (suffix)	Material condition for a product which is stress relieved.

Products in the M, R... or H... material condition may be specially processed (i.e. mechanically or thermally stress relieved) in order to lower the residual stress level to improve the resistance to stress corrosion and the dimensional stability on machining [see Clause 5 list entry m), list entry n) and 8.4].

Exact conversion between material conditions designated R... and H... is not possible.

Except when the suffix S is used, material condition is designated by only one of the above designations.

4.3 Product

The product designation provides a standardized pattern of designation from which a rapid and unequivocal description of a product is conveyed in communication. It provides mutual comprehension at the international level with regard to products which meet the requirements of the relevant European Standard.

The product designation is no substitute for the full content of the standard.

The product designation for products to this standard shall consist of:

- denomination (Rod);
- number of this document (EN 12163);

- material designation, either symbol or number (see Tables 1 to 8);
- DW for compliance in the chemical composition according to the 4 MS Common Composition List. This information is mandatory in the case in which the product is used for drinking water applications according to the 4 MS Common Composition List and not to be given in other cases (see Bibliography [4]);
- material condition designation (see Tables 9 to 16);
- cross-sectional shape (the following designations shall be used, as appropriate: RND for round, SQR for square, HEX for hexagonal, OCT for octagonal);
- nominal cross-sectional dimension (diameter or width across-flats);
- tolerance class (see Table 17);
- for polygonal rod, the corner shape (the following designations shall be used as appropriate: SH for sharp, RD for rounded), (see Table 19).

The derivation of a product designation is shown in the following examples.

EXAMPLE 1 Rod for general purposes conforming to this standard, in material designated either CuZn40 or CW509L, for standard applications, in material condition R410, hexagonal, nominal width across-flats 14 mm, tolerance Class B, rounded corners, will be designated as follows:

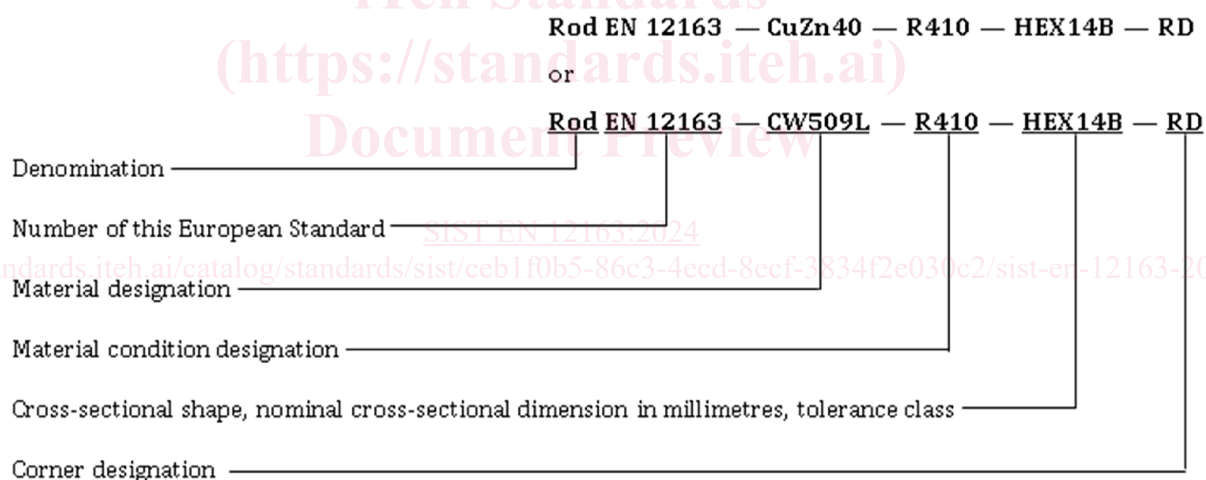

EXAMPLE 2 Rod for general purposes conforming to this standard, in material designated either CuZn40 or CW509L, for drinking water applications according to the 4 MS Common Composition List, in material condition R410, hexagonal, nominal width across-flats 14 mm, tolerance Class B, rounded corners, will be designated as follows:

EN 12163:2024 (E)

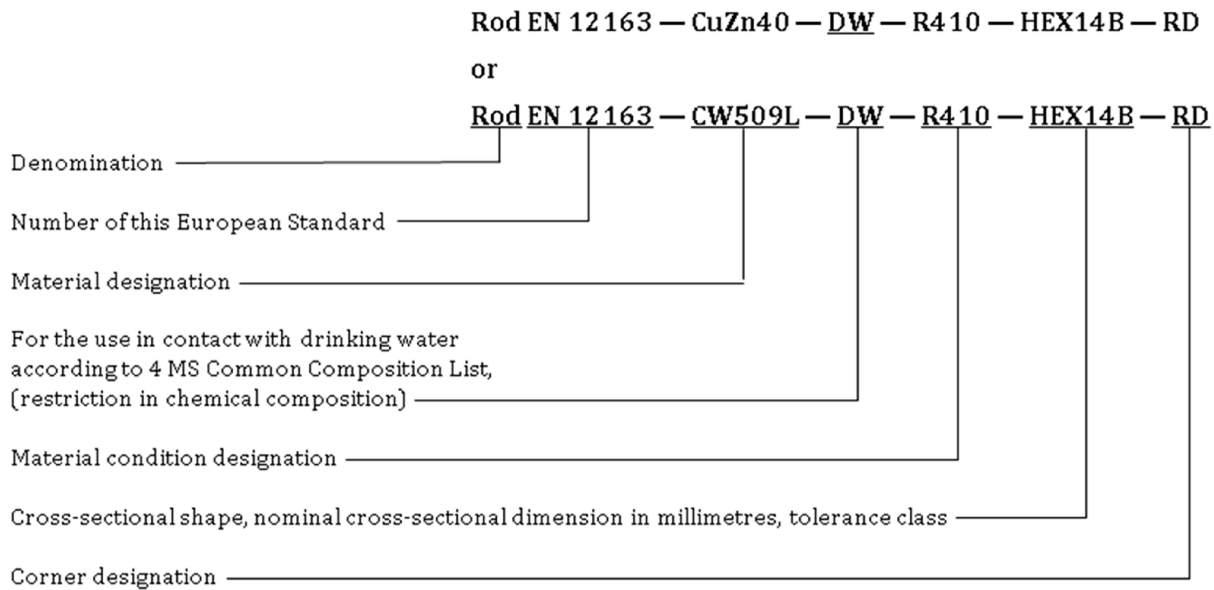

5 Ordering information

In order to facilitate the enquiry, order and confirmation of order procedures the following information shall be specified:

- a) mass of product required;
- b) denomination (Rod);
- c) number of this document (EN 12163);
- d) material designation (see Tables 1 to 8);
- e) material condition designation (see 4.2 and Tables 9 to 16) if it is other than M;
- f) DW for compliance in the chemical composition according to the 4 MS Common Composition List. This information is mandatory in the case in which the product is used for drinking water applications according to the 4 MS Common Composition List and not to be given in other cases;
- g) cross-sectional shape;
- h) nominal cross-sectional dimension (diameter or width across-flats);
- i) whether other than class A tolerances are required (see Table 17);
- j) for polygonal rod: whether “sharp” or “rounded” corners are required unless the corner radii shall be left to the discretion of the supplier (see 6.5.5 and Table 19);
- k) length and length tolerance (see 6.5.4).

It is recommended that the product designation, as described in 4.3, is used for items b) to k).

In addition, it shall also state on the enquiry and order any or the following, if required:

- l) whether the products according to 6.3, are required to pass a dezincification resistance test (see 8.4)