



SLOVENSKI STANDARD
oSIST prEN 12168:2022

01-oktober-2022

Baker in bakrove zlitine - Votle palice za obdelavo z odrezovanjem na avtomatih

Copper and copper alloys - Hollow rod for free machining purposes

Kupfer und Kupferlegierungen - Hohlstangen für die spanende Bearbeitung

Cuivre et alliages de cuivre - Barres creuses pour décolletage

Ta slovenski standard je istoveten z: prEN 12168

<https://standards.iteh.ai/catalog/standards/sist/1ffcd140-3e1d-4e07-b627-6482e449c7ad/osist-pren-12168-2022>

ICS:

77.150.30 Bakreni izdelki Copper products

oSIST prEN 12168:2022

en,fr,de

EUROPEAN STANDARD
NORME EUROPÉENNE
EUROPÄISCHE NORM

DRAFT
prEN 12168

August 2022

ICS 77.150.30

Will supersede EN 12168:2016

English Version

Copper and copper alloys - Hollow rod for free machining purposes

Cuivre et alliages de cuivre ζ Barres creuses pour
décolletage

Kupfer und Kupferlegierungen - Hohlstangen für die
spanende Bearbeitung

This draft European Standard is submitted to CEN members for enquiry. It has been drawn up by the Technical Committee CEN/TC 133.

If this draft becomes a European Standard, CEN members are bound to comply with the CEN/CENELEC Internal Regulations which stipulate the conditions for giving this European Standard the status of a national standard without any alteration.

This draft European Standard was established by CEN in three official versions (English, French, German). A version in any other language made by translation under the responsibility of a CEN member into its own language and notified to the CEN-CENELEC Management Centre has the same status as the official versions.

CEN members are the national standards bodies of Austria, Belgium, Bulgaria, Croatia, Cyprus, Czech Republic, Denmark, Estonia, Finland, France, Germany, Greece, Hungary, Iceland, Ireland, Italy, Latvia, Lithuania, Luxembourg, Malta, Netherlands, Norway, Poland, Portugal, Republic of North Macedonia, Romania, Serbia, Slovakia, Slovenia, Spain, Sweden, Switzerland, Turkey and United Kingdom.

Recipients of this draft are invited to submit, with their comments, notification of any relevant patent rights of which they are aware and to provide supporting documentation.

Warning : This document is not a European Standard. It is distributed for review and comments. It is subject to change without notice and shall not be referred to as a European Standard.



EUROPEAN COMMITTEE FOR STANDARDIZATION
COMITÉ EUROPÉEN DE NORMALISATION
EUROPÄISCHES KOMITEE FÜR NORMUNG

CEN-CENELEC Management Centre: Rue de la Science 23, B-1040 Brussels

Contents	Page
European foreword.....	4
Introduction	6
1 Scope	7
2 Normative references.....	7
3 Terms and definitions	8
4 Designations.....	9
4.1 Material.....	9
4.1.1 General.....	9
4.1.2 Symbol.....	9
4.1.3 Number	9
4.2 Material condition	9
4.3 Product.....	10
5 Ordering information	13
6 Requirements.....	14
6.1 Composition	14
6.2 Mechanical properties.....	14
6.3 Resistance to dezincification	14
6.4 Residual stress level.....	15
6.5 Dimensions and tolerances	15
6.5.1 Diameter or width across-flats.....	15
6.5.2 Tolerance on wall thickness.....	15
6.5.3 Eccentricity.....	15
6.5.4 Shape tolerances	15
6.5.5 Straightness.....	15
6.5.6 Length.....	16
6.5.7 Corner radii.....	16
6.5.8 Twist of polygonal hollow rod.....	16
6.6 Surface quality.....	17
6.7 Internal inclusion.....	17
7 Sampling.....	17
7.1 General.....	17
7.2 Analysis.....	17
7.3 Mechanical tests	18
7.4 Dezincification resistance and stress corrosion resistance tests.....	18
8 Test methods	18
8.1 Analysis.....	18
8.2 Tensile test	18
8.2.1 General.....	18
8.2.2 Location of test pieces	18
8.2.3 Shape and size of test pieces	19
8.2.4 Procedure for testing.....	19
8.2.5 Determination of results	19

8.3	Hardness test.....	19
8.4	Dezincification resistance test.....	19
8.5	Stress corrosion resistance test	19
8.6	Retests	19
8.6.1	Analysis, tensile, hardness and dezincification resistance tests.....	19
8.6.2	Stress corrosion resistance test	20
8.7	Rounding of results.....	20
9	Declaration of conformity and inspection documentation	20
9.1	Declaration of conformity	20
9.2	Inspection documentation	20
10	Marking, packaging, labelling	21
Annex ZA (informative) Relationship between this European Standard and the essential requirements of Directive 2014/68/EU (Pressure equipment Directive) aimed to be covered.....		37
Bibliography		38

iTeh STANDARD PREVIEW (standards.iteh.ai)

[oSIST prEN 12168:2022](https://standards.iteh.ai/catalog/standards/sist/1ffcd140-3e1d-4e07-b627-6482e449c7ad/osist-pren-12168-2022)

<https://standards.iteh.ai/catalog/standards/sist/1ffcd140-3e1d-4e07-b627-6482e449c7ad/osist-pren-12168-2022>

prEN 12168:2022 (E)**European foreword**

This document (prEN 12168:2022) has been prepared by Technical Committee CEN/TC 133 “Copper and copper alloys”, the secretariat of which is held by DIN.

This document is currently submitted to the CEN Enquiry.

This document will supersede EN 12168:2016.

In comparison with EN 12168:2016, the following significant technical changes were made:

- a) Modified the note in Clause 1;
- b) Introduction in 6.6 of eddy current test parameters;
- c) Introduction of 6.7 Internal inclusion;
- d) Modified the definition of diameter or width across-flats at 6.5.4.1;
- e) Added a new Figure for straightness at 6.5.5 and modified values in Table 13;
- f) Introduction in the chemical composition Tables of a footnote to explain the meaning of elements for which no upper and lower limits are defined;
- g) Deleted alloys groups in Table 3;
- h) Chemical composition of CuZn39Pb3 (CW614N), CuZn40Pb2 (CW617N), CuZn35Pb1,5AlAs (CW625N) and CuZn33Pb1,5AlAs (CW626N) modified in Table 3;
- i) Added a new alloy CuZn40Pb1 (CW627N) in Table 6 and Table 7;
- j) Chemical composition of CuZn33Pb1AlSiAs (CW725R) modified in Table 4;
- k) Added a new alloy CuZn36Si1P (CW726R) in Table 4 and Table 8
- l) Modified the range of dimensions in Table 9 and in Table 11;
- m) Table 18 and Table 19 added;
- n) Annex ZA added.

This document is one of a series of European Standards for the copper and copper alloy products rod, wire, profile and forgings. Other products are specified as follows:

- EN 12163, *Copper and copper alloys — Rod for general purposes*;
- EN 12164, *Copper and copper alloys — Rod for free machining purposes*;
- EN 12165, *Copper and copper alloys — Wrought and unwrought forging stock*;
- EN 12166, *Copper and copper alloys — Wire for general purposes*;
- EN 12167, *Copper and copper alloys — Profiles and bars for general purposes*;

- EN 13601, *Copper and copper alloys — Copper rod, bar and wire for general electrical purposes*;
- EN 13602, *Copper and copper alloys — Drawn, round copper wire for the manufacture of electrical conductors*;
- EN 13605, *Copper and copper alloys — Copper profiles and profiled wire for electrical purposes*.

This document has been prepared under a Standardization Request given to CEN by the European Commission and the European Free Trade Association, and supports essential requirements of EU Directive(s) / Regulation(s).

For relationship with EU Directive(s) / Regulation(s), see informative Annex ZA, which is an integral part of this document.

iTeh STANDARD PREVIEW
(standards.iteh.ai)

[oSIST prEN 12168:2022](https://standards.iteh.ai/catalog/standards/sist/1ffcd140-3e1d-4e07-b627-6482e449c7ad/osist-pren-12168-2022)

<https://standards.iteh.ai/catalog/standards/sist/1ffcd140-3e1d-4e07-b627-6482e449c7ad/osist-pren-12168-2022>

Introduction

The European Committee for Standardization (CEN) draws attention to the fact that it is claimed that compliance with this document may involve the use of a patent concerning the alloy CuZn33Pb1AlSiAs (CW725R) and CuZn36Si1P (CW726R) given in 6.1.

CEN takes no position concerning the evidence, validity and scope of this patent right.

The holder of this patent right has ensured the CEN that he is willing to negotiate licenses under reasonable and non-discriminatory terms and conditions with applicants throughout the world. In this respect, the statement of the holder of this patent right is registered with CEN.

— For CuZn33Pb1AlSiAs (CW725R) information may be obtained from:

Diehl Brass Solutions Stiftung & Co. KG
Heinrich-Diehl-Straße 9
D-90552 Röthenbach/Pegnitz
GERMANY

— For CuZn36Si1P (CW726R) information may be obtained from:

Luvata Oy
Kuparitie 5
28330 Pori
FINLAND

iTeh STANDARD PREVIEW

Attention is drawn to the possibility that some of the elements of this document may be the subject of patent rights other than those identified above. CEN shall not be held responsible for identifying any or all such patent rights.

CEN and CENELEC maintain online lists of patents relevant to their standards. Users are encouraged to consult the lists for the most up to date information concerning patents (<ftp://ftp.cenelec.eu/EN/IPR/Patents/IPRdeclaration.pdf>).

Due to developing legislation, the composition of a material may be restricted to the composition specified in this European Standard with respect to individual uses (e.g. for the use in contact with drinking water in some Member States of the European Union). These individual restrictions are not part of this European Standard. Nevertheless, for materials for which traditional and major uses are affected, these restrictions are indicated. The absence of an indication, however, does not imply that the material can be used in any application without any legal restriction.

1 Scope

This document specifies the composition, property requirements and dimensional tolerances for copper alloy hollow rod, finally produced by drawing or extruding, specifically intended for free machining purposes.

NOTE Hollow products having an outside diameter greater than 80 mm and/or a wall thickness less than 2 mm are most frequently specified in EN 12449.

The sampling procedures, the methods of test for verification of conformity to the requirements of this document, are also specified.

2 Normative references

The following documents are referred to in the text in such a way that some or all of their content constitutes requirements of this document. For dated references, only the edition cited applies. For undated references, the latest edition of the referenced document (including any amendments) applies.

EN 764-5:2014, *Pressure equipment - Part 5: Inspection documentation of metallic materials and compliance with the material specification*

EN 1173:2008, *Copper and copper alloys - Material condition designation*

EN 1412:2016, *Copper and copper alloys - European numbering system*

EN 10204:2004, *Metallic products - Types of inspection documents*

EN 14977:2006, *Copper and copper alloys - Detection of tensile stress - 5 % ammonia test*

EN 17263:2019, *Copper and copper alloys - Eddy current testing on the outer surface of rods, bars, hollow rods and wires for the detection of defects by encircling test coil*

EN ISO 6506-1:2014, *Metallic materials - Brinell hardness test - Part 1: Test method (ISO 6506-1:2014)*

EN ISO 6507-1:2018, *Metallic materials - Vickers hardness test - Part 1: Test method (ISO 6507-1:2018)*

EN ISO 6509-1:2014, *Corrosion of metals and alloys - Determination of dezincification resistance of copper alloys with zinc - Part 1: Test method (ISO 6509-1:2014)*

EN ISO 6892-1:2019, *Metallic materials - Tensile testing - Part 1: Method of test at room temperature (ISO 6892-1:2019)*

ISO 1190-1:1982, *Copper and copper alloys — Code of designation — Part 1: Designation of materials*

ISO 6957:1988, *Copper alloys — Ammonia test for stress corrosion resistance*

3 Terms and definitions

For the purposes of this document, the following terms and definitions apply.

ISO and IEC maintain terminological databases for use in standardization at the following addresses:

- IEC Electropedia: available at <http://www.electropedia.org/>
- ISO Online browsing platform: available at <http://www.iso.org/obp>

3.1

hollow rod

straight product, of uniform cross-section along its whole length with an enclosed void for which the longitudinal axes of its external contour and its internal contour, which is the boundary with the enclosed void, are coincidental

Note 1 to entry: The external and internal contours of the rod, at any cross-section, can be that of a circle, square, rectangle, hexagon, or octagon, or with slight modification of those basic shapes by inclusion of detail(s) of relatively small size to the remainder of the cross-section. Examples of hollow rod cross-sections are shown in Figure 1.

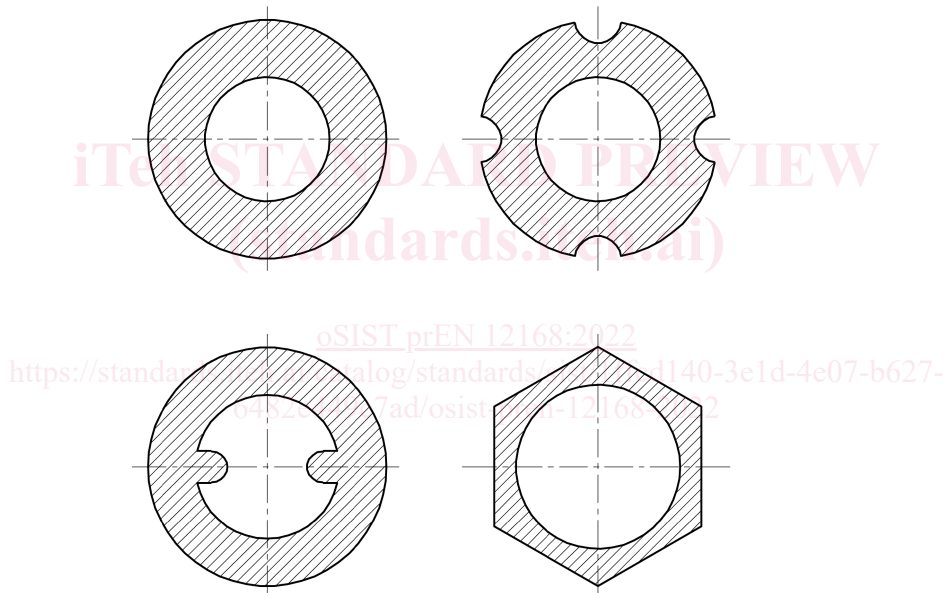

Figure 1 — Examples of hollow rod cross-sections

3.2

deviation from circular form

difference between the maximum and the minimum outside diameters measured at any one cross-section of the product

3.3

eccentricity

difference between the maximum and the minimum wall thickness, measured in the same cross-section perpendicular to the axis of the hollow rod, expressed as a percentage of the sum of the maximum and minimum wall thicknesses ($s_{\max.}$ and $s_{\min.}$):

$$e = \frac{s_{\max.} - s_{\min.}}{s_{\max.} + s_{\min.}} \times 100$$

Note 1 to entry: For polygons, wall thickness is measured perpendicular to the mid-points of the flat outside surfaces.

4 Designations

4.1 Material

4.1.1 General

The material is designated either by symbol or by number (see Tables 1 to 4).

4.1.2 Symbol

The material symbol designation is based on the designation system given in ISO 1190-1:1982.

NOTE Although material symbol designations used in this standard might be the same as those in other standards using the designation system given in ISO 1190-1:1982, the detailed composition requirements are not necessarily the same.

4.1.3 Number

The material number designation is in accordance with the system given in EN 1412:2016.

4.2 Material condition

For the purposes of this document, the following designations, which are in accordance with the system given in EN 1173:2008, apply for the material condition:

- | | |
|------------|--|
| M | material condition for the product as manufactured without specified mechanical properties; |
| R... | material condition designated by the minimum value of tensile strength requirement for the product with mandatory tensile property requirements; |
| H... | material condition designated by the minimum value of hardness requirement for the product with mandatory hardness requirements; |
| S (suffix) | material condition for a product which is stress relieved. |

Products in the M or H... material condition may be specially processed (i.e. mechanically or thermally stress relieved) in order to lower the residual stress level to improve the resistance to stress corrosion and the dimensional stability on machining [see Clause 5 list entry k), list entry l) and 8.5].

Except when the suffix S is used, material condition is designated by only one of the above designations.

prEN 12168:2022 (E)**4.3 Product**

The product designation provides a standardized pattern of designation from which a rapid and unequivocal description of a product can be conveyed in communication. It provides mutual comprehension at the international level with regard to products which meet the requirements of the relevant document.

The product designation is no substitute for the full content of the document.

The product designation for products to this document shall consist of:

- a) denomination (hollow rod);
- b) number of this European Standard (EN 12168);
- c) material designation, either symbol or number (see Tables 1 to 4);
- d) DW for compliance in the chemical composition according to the 4 MS Common Composition List. This information is mandatory in the case in which the product is used for drinking water applications according to the 4 MS Common Composition List and not to be given in other cases;
- e) material condition designation (see Tables 5 to 8);
- f) external and/or internal cross-sectional shape (the following designations shall be used as appropriate: RND for round, SQR for square, RCT for rectangular, HEX for hexagonal, OCT for octagonal, PFL for profile);
- g) nominal cross-sectional dimensions (see Clause 5, list entry g)) or, for profiles, the number of the profile or a fully dimensioned and toleranced drawing, and:
 - 1) tolerance class A, B or C added to the external dimension (see Table 9); and/or
 - 2) tolerance class A or B added to the bore diameter (see Table 11);
- h) wall thickness (the following designation shall be used for wall thickness: WT) (see Table 10);
- i) for square, hexagonal or octagonal external shape, the corner shape (the following designations shall be used as appropriate: SH for sharp, RD for rounded) (see Table 15).

A typical product designation is shown in the following examples.

EXAMPLE 1 Hollow rod for free machining purposes conforming to this document, in material designated either CuZn40Pb2 or CW617N, for standard applications, in material condition H090, round external shape and bore, nominal outside diameter 40 mm, tolerance Class B, and nominal wall thickness 10 mm will be designated as follows:

Hollow rod EN 12168 — CuZn40Pb2 — H090 — RND40B × WT10

or

Hollow rod EN 12168 — CW617N — H090 — RND40B × WT10

Denomination

Number of European Standard

Material designation

Material condition designation

Cross-sectional shape, nominal cross-sectional dimensions in millimetres,
tolerance class, nominal wall thickness

EXAMPLE 2 Hollow rod for free machining purposes conforming to this document, in material designated either CuZn40Pb2 or CW617N, for drinking water applications according to the 4 MS Common Composition List, in material condition H090, round external shape and bore, nominal outside diameter 40 mm, tolerance Class B, and nominal wall thickness 10 mm will be designated as follows:

Hollow rod EN 12168 — CuZn40Pb2 — DW — H090 — RND40B × WT10

or

Hollow rod EN 12168 — CW617N — DW — H090 — RND40B × WT10

Denomination

Number of European Standard

Material designation

For the use in contact with drinking water
according to 4 MS Common Composition List,
(restriction in chemical composition)

Material condition designation

Cross-sectional shape, nominal cross-sectional dimensions in millimetres,
tolerance class, nominal wall thickness

EXAMPLE 3 Hollow rod for free machining purposes conforming to this document, in material designated either CuZn40Pb2 or CW617N, for standard applications, in material condition H090, hexagonal external shape, 60 mm nominal width across-flats dimension, tolerance Class A, round bore of nominal diameter 20 mm, tolerance Class B sharp corners, will be designated as follows: