

---

---

**Controlled equivalence ratio method  
for the determination of hazardous  
components of fire effluents — Steady-  
state tube furnace**

*Méthode du rapport d'équivalence contrôlée pour la détermination  
des substances dangereuses des effluents du feu — Four tubulaire à  
conditions stables*

iTeh STANDARD PREVIEW  
(standards.iteh.ai)

[ISO/TS 19700:2016](https://standards.iteh.ai/catalog/standards/sist/8d4865bc-84ab-4949-9505-51ecc541a066/iso-ts-19700-2016)

<https://standards.iteh.ai/catalog/standards/sist/8d4865bc-84ab-4949-9505-51ecc541a066/iso-ts-19700-2016>



**iTeh STANDARD PREVIEW**  
**(standards.iteh.ai)**

ISO/TS 19700:2016

<https://standards.iteh.ai/catalog/standards/sist/8d4865bc-84ab-4949-9505-51ecc541a066/iso-ts-19700-2016>



**COPYRIGHT PROTECTED DOCUMENT**

© ISO 2016, Published in Switzerland

All rights reserved. Unless otherwise specified, no part of this publication may be reproduced or utilized otherwise in any form or by any means, electronic or mechanical, including photocopying, or posting on the internet or an intranet, without prior written permission. Permission can be requested from either ISO at the address below or ISO's member body in the country of the requester.

ISO copyright office  
Ch. de Blandonnet 8 • CP 401  
CH-1214 Vernier, Geneva, Switzerland  
Tel. +41 22 749 01 11  
Fax +41 22 749 09 47  
copyright@iso.org  
www.iso.org

# Contents

	Page
<b>Foreword</b> .....	<b>v</b>
<b>Introduction</b> .....	<b>vi</b>
<b>1 Scope</b> .....	<b>1</b>
<b>2 Normative references</b> .....	<b>2</b>
<b>3 Terms and definitions</b> .....	<b>2</b>
<b>4 Principle</b> .....	<b>3</b>
<b>5 Apparatus</b> .....	<b>4</b>
5.1 General apparatus.....	4
5.2 Tubular furnace.....	4
5.3 Calibrated thermocouples.....	6
5.4 Quartz furnace tube.....	6
5.5 Combustion boat.....	6
5.6 Combustion boat drive.....	7
5.6.1 Mechanism.....	7
5.6.2 Rate of specimen introduction.....	7
5.7 Mixing and measurement chamber.....	8
5.8 Analysis of gases.....	8
5.9 Determination of smoke aerosols.....	10
5.10 Exhaust system.....	10
<b>6 Air supplies</b> .....	<b>10</b>
6.1 Primary and secondary air supplies.....	10
6.2 Primary airflow calibration.....	10
6.3 Secondary airflow calibration.....	11
6.4 Overall confirmation.....	11
<b>7 Establishment of furnace temperature and setting of furnace temperature</b> .....	<b>11</b>
7.1 General.....	11
7.2 Establishing furnace temperature profile to determine furnace suitability.....	12
7.3 Setting the temperature for an individual test run condition.....	12
<b>8 Test specimen preparation</b> .....	<b>13</b>
8.1 Test specimen form.....	13
8.2 Combustible loading.....	13
8.3 Specimen conditioning.....	13
<b>9 Selection of test decomposition conditions</b> .....	<b>13</b>
9.1 Selection of decomposition conditions for fire hazard analysis or fire safety engineering.....	13
9.2 Stage 1b): oxidative pyrolysis from externally applied radiation.....	14
9.3 Stage 2: well-ventilated flaming.....	14
9.4 Stage 3a): small vitiated fires in closed or poorly ventilated compartments.....	15
9.5 Stage 3b): post-flashover fires in open compartments.....	16
<b>10 Procedure</b> .....	<b>16</b>
10.1 Safety considerations.....	16
10.2 Decomposition of the test specimen.....	16
10.3 Steady-state period.....	18
10.4 Sampling and analysis of fire effluent.....	18
10.4.1 General.....	18
10.4.2 Sampling of fire effluent.....	18
10.4.3 Determination of the mass of the specimen residue.....	20
10.4.4 Ambient conditions.....	20
10.5 Validity of test run.....	21
<b>11 Calculations</b> .....	<b>21</b>
11.1 General.....	21

11.2	Mass-charge concentration and mass-loss concentration.....	21
11.2.1	Mass-charge concentration.....	21
11.2.2	Mass-loss concentration.....	21
11.3	Yield.....	22
11.4	Organic fraction.....	24
<b>12</b>	<b>Test report.....</b>	<b>24</b>
12.1	Contents of test report.....	24
12.2	Test laboratory details.....	25
12.3	Specimen details.....	25
12.4	Test conditions and procedures.....	25
<b>13</b>	<b>Verification of test apparatus with PMMA.....</b>	<b>26</b>
13.1	Procedure.....	26
13.2	Verification criteria.....	26
<b>14</b>	<b>Trueness and uncertainties with respect to steady-state tube furnace concentration and yields.....</b>	<b>26</b>
14.1	Accuracy, trueness and uncertainty.....	26
14.2	Accuracy and trueness of concentration and yield measurements in the steady-state tube furnace (SSTF).....	26
14.3	Extent of variability of concentration and yield measurements from test specimens in the steady-state tube furnace.....	27
14.4	Correlation of effluent yields from the steady-state tube furnace with those obtained from large-scale compartment fire tests under the same combustion conditions.....	27
<b>15</b>	<b>Repeatability and reproducibility.....</b>	<b>28</b>
<b>Annex A</b>	<b>(informative) Guidance on the choice of additional decomposition conditions.....</b>	<b>30</b>
<b>Annex B</b>	<b>(informative) Estimation of lethal toxic potency for combustion products according to ISO 13344 using tube-furnace data.....</b>	<b>32</b>
<b>Annex C</b>	<b>(informative) Application of data from the tube-furnace test to estimation and assessment of toxic hazard in fires according to ISO 13571.....</b>	<b>33</b>
<b>Annex D</b>	<b>(informative) Use of the tube-furnace method for bioassay purposes.....</b>	<b>34</b>
<b>Annex E</b>	<b>(informative) Measurement of optical density from the steady-state tube furnace.....</b>	<b>35</b>
<b>Annex F</b>	<b>(informative) Comparison of data from the steady-state tube furnace, the ISO 9705 room and other compartment fire experiments.....</b>	<b>37</b>
<b>Annex G</b>	<b>(informative) Assessment of mass-loss rate data.....</b>	<b>41</b>
<b>Bibliography</b>	<b>.....</b>	<b>46</b>

## Foreword

ISO (the International Organization for Standardization) is a worldwide federation of national standards bodies (ISO member bodies). The work of preparing International Standards is normally carried out through ISO technical committees. Each member body interested in a subject for which a technical committee has been established has the right to be represented on that committee. International organizations, governmental and non-governmental, in liaison with ISO, also take part in the work. ISO collaborates closely with the International Electrotechnical Commission (IEC) on all matters of electrotechnical standardization.

The procedures used to develop this document and those intended for its further maintenance are described in the ISO/IEC Directives, Part 1. In particular the different approval criteria needed for the different types of ISO documents should be noted. This document was drafted in accordance with the editorial rules of the ISO/IEC Directives, Part 2 (see [www.iso.org/directives](http://www.iso.org/directives)).

Attention is drawn to the possibility that some of the elements of this document may be the subject of patent rights. ISO shall not be held responsible for identifying any or all such patent rights. Details of any patent rights identified during the development of the document will be in the Introduction and/or on the ISO list of patent declarations received (see [www.iso.org/patents](http://www.iso.org/patents)).

Any trade name used in this document is information given for the convenience of users and does not constitute an endorsement.

For an explanation on the meaning of ISO specific terms and expressions related to conformity assessment, as well as information about ISO's adherence to the World Trade Organization (WTO) principles in the Technical Barriers to Trade (TBT) see the following URL: [www.iso.org/iso/foreword.html](http://www.iso.org/iso/foreword.html).

The committee responsible for this document is ISO/TC 92, *Fire safety*, Subcommittee SC 3, *Fire threat to people and environment*.

This second edition cancels and replaces the first edition (ISO/TS 19700:2007), which has been technically revised.

The changes in this document are as follows.

- The interlaboratory reproducibility has been assessed with homogenous thermoplastic materials.
- A verification procedure of the test apparatus with PMMA has been introduced.
- A new section on trueness and uncertainties with respect to steady-state tube furnace concentration and yields has been added.
- A new section on repeatability and reproducibility has been added.
- New informative annexes have been added (see [Annexes F](#) and [G](#)).
- The list of references has been updated.

## Introduction

Fire safety engineering using performance-based design requires engineering methods for specific performance aspects of fire safety, but applicable to all types of structural systems, products and processes. This includes standard test methods for obtaining data on specific fire-related phenomena including the generation of harmful fire effluents. These have been designed to provide the input data necessary for engineering calculation methods for physical, chemical and biological properties. The exposure conditions and performance need to be adequately quantified to allow extrapolation from test conditions to different fire situations occurring in the real world.

The toxic hazard to an occupant of a building or transport enclosure during a fire depends on exposure to the time-varying concentrations of toxic products (gases and smoke particulates) in each occupant's breathing zone, the effect of each toxicant and the interactions between them. The concentrations of toxic gases and particles depend primarily on the mass-loss rate of the fuel, the yields of each toxicant and the dynamics of air entrainment and effluent dispersal within the occupied enclosure(s). Other factors, such as losses from deposition on the walls of the enclosure, may also need to be considered.

For fire safety calculations, such as those described in ISO 16732-1<sup>[1]</sup>, the yields of toxic products from the burning fuel are necessary inputs. Since combustion conditions vary during a fire and between different fires, it is also necessary to measure the toxic product yields under a range of defined combustion conditions. In order to make a performance-based assessment of the toxic hazard in a fire, yield data of toxic products under different specified fire conditions comprise one category of the required inputs.

For any specific material, the effluent yields in fires depend upon the thermal decomposition conditions. The most important variables are whether the decomposition is non-flaming or flaming, and for flaming decomposition, the fuel/oxygen ratio. Based upon these variables, it is possible to classify fires into a number of types, as detailed in ISO 19706:2011, Table 1.

This method has been developed to measure toxic product yields from materials over a range of defined decomposition conditions in fires. At this stage, the interlaboratory reproducibility has been assessed with homogenous thermoplastic materials, and this document is therefore limited in applicability to such materials. The decomposition conditions are defined in terms of fuel/air equivalence ratio, temperature and flaming behaviour.

The method has been shown to replicate the production yields of toxic fire effluents in a number of studies for a range of polymers, described in [14.4](#) and [Annex F](#).

The use of this document provides data on the range of toxic product yields likely to occur in different types and stages of full-scale fires. More comprehensive data on the relationships between decomposition conditions and product yields can be obtained by using a wider range of apparatus settings. Guidance on the choice of additional decomposition conditions is given in [Annex A](#). The estimation of lethal toxic potency data according to ISO 13344 is described in [Annex B](#). The use of data to assess toxic hazard according to ISO 13571 is described in [Annex C](#). Guidance on the application of data for bioassay purposes is described in [Annex D](#).

The test method has been developed to fulfil the requirements of ISO 16312-1 and ISO 19706, for data on the yields of toxic products in fire effluents evolved under different fire conditions as part of the data required for input to the toxic-hazard-assessment calculation methods described in ISO 13571. The data may also be used as input for the toxic-potency calculation methods described in ISO 13344 and ISO 13571.

# Controlled equivalence ratio method for the determination of hazardous components of fire effluents — Steady-state tube furnace

## 1 Scope

This document describes a steady-state tube furnace (SSTF) method for the generation of fire effluent for the identification and measurement of its constituent combustion products, in particular, the yields of toxicants under a range of fire decomposition conditions.

It uses a moving test specimen and a tube furnace at different temperatures and airflow rates as the fire model. The interlaboratory reproducibility has been assessed with selected homogenous thermoplastic materials and this document is therefore limited in applicability to such materials. The method is validated for testing homogeneous thermoplastic materials that produce yields of a defined consistency. See limitations in [Clause 12](#).

This method has been designed as a performance-based engineering method to provide data for input to hazard assessments and fire safety engineering design calculations. The method can be used to model a wide range of combustion conditions by using different combinations of temperature, non-flaming and flaming decomposition conditions and different fuel/oxygen ratios in the tube furnace. These include the combustion conditions for the following types of fires, as detailed in ISO 19706:2011, Table 1:

- Stage 1: Non-flaming:
  - Stage 1b) Oxidative pyrolysis from externally applied radiation;
- Stage 2: Well-ventilated flaming (representing a flaming developing fire);
- Stage 3: Under-ventilated flaming:
  - Stage 3a) Small localized fires in closed or poorly ventilated compartments;
  - Stage 3b) Post-flashover fires.

For each flaming fire type, the minimum conditions of test are specified in terms of the equivalence ratio,  $\phi$ , as follows:

Stage 2	$\phi \leq 0,75$ ;
Stages 3a) and 3b)	$\phi = 2 \pm 0,2$ .

Guidance on the choice of additional decomposition conditions is given in [Annex A](#).

The data on toxic product concentrations and yields obtained using this document can be used as part of the estimation of toxic potencies, in conjunction with toxic potency calculation methods in ISO 13344, and as an input to the toxic hazard assessment from fires in conjunction with fire growth and effluent dispersal modelling, and fractional effective dose (FED) calculation methods in ISO 13571.

Application of data from the steady-state tube furnace to the estimation of lethal toxic potency and to the assessment of toxic hazards in fires is considered in [Annex B](#) and [Annex C](#), respectively. Guidance on application of data from the steady-state tube furnace to the use of the steady-state tube furnace method for bioassay purposes is given in [Annex D](#).

The test method described in this document can be used solely to measure and describe the production of toxic effluent from homogeneous thermoplastic materials, in response to heat or flame under controlled laboratory conditions. It is not suitable to be used, by itself, for describing or appraising



the fire hazard of materials under actual fire conditions, or as the sole source on which regulations pertaining to toxicity can be based.

The yields of combustion products determined using this document pertain to the time interval during which steady-state burning is observed. To the extent that this interval is not a large fraction of the total burning time (i.e. if less than 5 min), the steady-state yield values are applicable with caution to fire safety analyses.

## 2 Normative references

The following documents are referred to in the text in such a way that some or all of their content constitutes requirements of this document. For dated references, only the edition cited applies. For undated references, the latest edition of the referenced document (including any amendments) applies.

ISO 291, *Plastics — Standard atmospheres for conditioning and testing*

ISO 12828-1, *Validation method for fire gas analysis — Part 1: Limits of detection and quantification*

ISO 12828-2, *Validation method for fire gas analysis — Part 2: Intralaboratory validation of quantification methods*

ISO 13344, *Estimation of the lethal toxic potency of fire effluents*

ISO 13571, *Life-threatening components of fire — Guidelines for the estimation of time to compromised tenability in fires*

ISO 19701, *Methods for sampling and analysis of fire effluents*

ISO 19702, *Guidance for sampling and analysis of toxic gases and vapours in fire effluents using Fourier Transform Infrared (FTIR) spectroscopy*

ISO 29903, *Guidance for comparison of toxic gas data between different physical fire models and scales*

ISO/IEC Guide 98-3, *Uncertainty of measurement — Part 3: Guide to the expression of uncertainty in measurement (GUM:1995)*

## 3 Terms and definitions

For the purposes of this document, the terms and definitions given in ISO 13344, ISO 13571, ISO 13943, and the following apply.

ISO and IEC maintain terminological databases for use in standardization at the following addresses:

- IEC Electropedia: available at <http://www.electropedia.org/>
- ISO Online browsing platform: available at <http://www.iso.org/obp>

### 3.1 accuracy

extent to which the measured value represents the true value, including the variability and uncertainties of the measured value

Note 1 to entry: The extent to which yields measured in the tube furnace for a specimen are predictive of the yields occurring when specimens are decomposed under the same combustion condition in large-scale compartment fire tests describes accuracy in this case.

Note 2 to entry: Definition of the accuracy of a measured value of a product concentration or yield from a tube furnace test run, see also [Clause 14](#).



**3.2****sample**

gas-phase fire effluent removed for analysis

**3.3****specimen**

representative piece of the homogeneous material to be tested

**3.4****steady-state burning conditions**

combustion of fuel at a constant rate under constant ventilation, providing constant combustion conditions

Note 1 to entry: The steady-state tube furnace is designed to combust test specimens under steady-state conditions, by introducing fuel into the furnace at a constant rate under a constant flow of air. During a test run, steady-state conditions can be confirmed by continuous measurement of the carbon dioxide and oxygen concentrations. The criteria of steady-state combustion conditions using this method are defined in [10.3](#).

**4 Principle**

The yields of combustion products from fires depend upon the decomposition conditions.<sup>[2][3][4][5][6]</sup> The specified test conditions have been chosen to replicate oxidative pyrolysis under non-flaming conditions, well-ventilated flaming conditions at an equivalence ratio of less than 0,75, under-ventilated pre-flashover flaming conditions and post-flashover under-ventilated flaming conditions, both at an equivalence ratio of around 2 as defined in ISO 19706. The test is designed to combust materials under a range of conditions, different fuel/air equivalence ratios and temperatures. This test combusts materials under defined conditions with respect to non-flaming and flaming combustion, different fuel/air equivalence ratios and temperatures experienced in real fires as defined in ISO 19706. It is essential that proper observations are made during testing to ensure that the specified conditions are being met.

<https://standards.iteh.ai/catalog/standards/sist/8d4865bc-84ab-4949-9505-537ed5412d66/iso-ts-19700-2016>

Specimens of a material are combusted under one or more steady-state conditions whose temperature and equivalence ratio are representative of a particular stage of a fire. A test specimen (in the form of granules or pellets, or as a continuous material) is uniformly distributed along an 800 mm quartz combustion boat. This is introduced at a constant rate into a quartz furnace tube which passes through a fixed tubular furnace. A stream of primary air is passed through the quartz furnace tube and over the test specimen at constant flow. The test specimen is driven into the hot zone of the tubular furnace. Under flaming conditions, ignition occurs, then the flame stabilizes, burning the test specimen at a fixed rate, in the presence of a controlled flow of primary air. The fire effluent moves through the quartz furnace tube into a mixing and measurement chamber where it is diluted with secondary air, giving a total flow of  $(50 \pm 1) \text{ dm}^3 \cdot \text{min}^{-1}$  through the chamber, and is then exhausted to the fume extraction system.

In oxidative pyrolysis conditions, the furnace temperature is set below the auto-ignition temperature. The three flaming conditions are accomplished by using furnace temperatures above the auto-ignition temperature. For flaming decomposition conditions, different, constant primary airflows are used at a constant rate of introduction of the test specimen to obtain different fuel-to-oxygen ratios, and hence different equivalence ratios.

The secondary, dilution air generates a greater sample flow and cooler effluent which permits a large number of gas and smoke sampling procedures to be used without the need for additional replicate tests.

The requirement in each test run is to obtain stable, steady-state decomposition conditions, for at least 5 min, or longer if possible, during which the concentrations of effluent gases and particles shall be measured. The time taken for steady-state conditions to be established varies, depending upon the nature of the test specimen and the test conditions.

The concentrations of carbon dioxide and oxygen are recorded continuously to identify the period in which steady-state burning conditions occur and samples of the effluent mixture are taken from the chamber during the steady-state period for analysis. A sample of smoke shall be drawn through a filter and the mass of particles is determined.

## 5 Apparatus

### 5.1 General apparatus

The apparatus consists of a tubular furnace and a quartz furnace tube which passes through the furnace and into a mixing and measurement chamber. A drive mechanism pushes the combustion boat into the quartz furnace tube at a pre-set, controlled rate. A constant, known flow of primary air moves through the quartz furnace tube, over the moving test specimen, to the mixing and measurement chamber. A controlled secondary supply goes directly into the mixing and measurement chamber. Gaseous samples are taken from the mixing and measurement chamber.

The arrangement of the apparatus is shown in [Figure 1](#). Unless otherwise stated, all tolerances are  $\pm 5$  mm.

NOTE A light/photo cell system can be used to determine smoke density across the mixing and measurement chamber (see [Annex E](#)).

### 5.2 Tubular furnace

The tubular furnace shall have a heating zone length of 500 mm to 800 mm and an inside diameter of 50 mm to 65 mm. The furnace shall be equipped with an adjustable electric heating system capable of reaching 1 000 °C and maintaining the furnace temperature to within  $\pm 2$  % of the set temperature with an empty quartz furnace tube in place under static conditions.

The heating element should preferably be rated at 1 300 °C. The furnace is similar to that used in IEC 60754-2.

With the peak furnace temperature set at  $(650 \pm 10)$  °C, the temperature shall not decrease by more than 100 °C over a length of at least  $\pm 125$  mm from the point of peak temperature measurement. The method used to determine this temperature profile is given in [7.2](#).

NOTE This will also reduce the likelihood of a hot spot in the furnace, to which the pyrolysis rate will be sensitive.

iTeh STANDARD PREVIEW

(standards.iteh.ai)

ISO/TS 19700:2016

https://standards.iteh.ai/catalog/standards/sist/51ecc541a066/iso-ts-19700-2016

51ecc541a066/iso-ts-19700-2016

Dimensions in millimetres

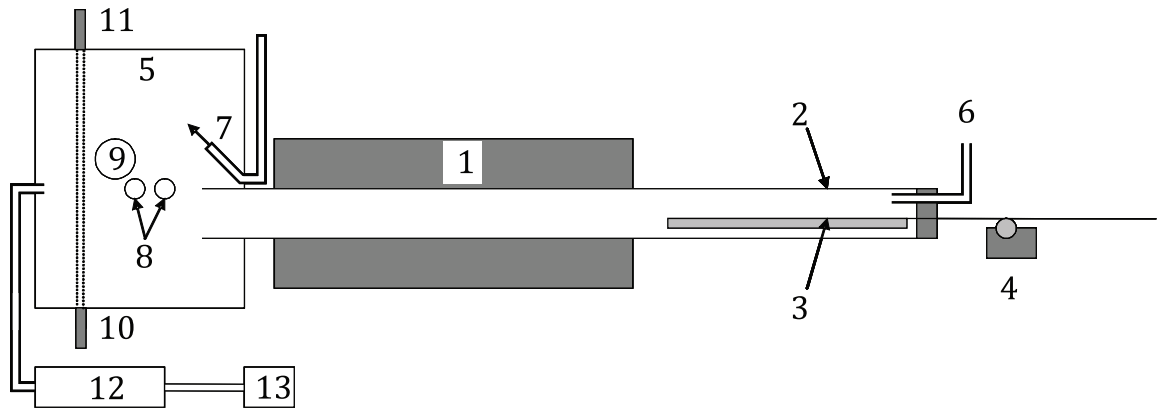

a) General arrangement of apparatus

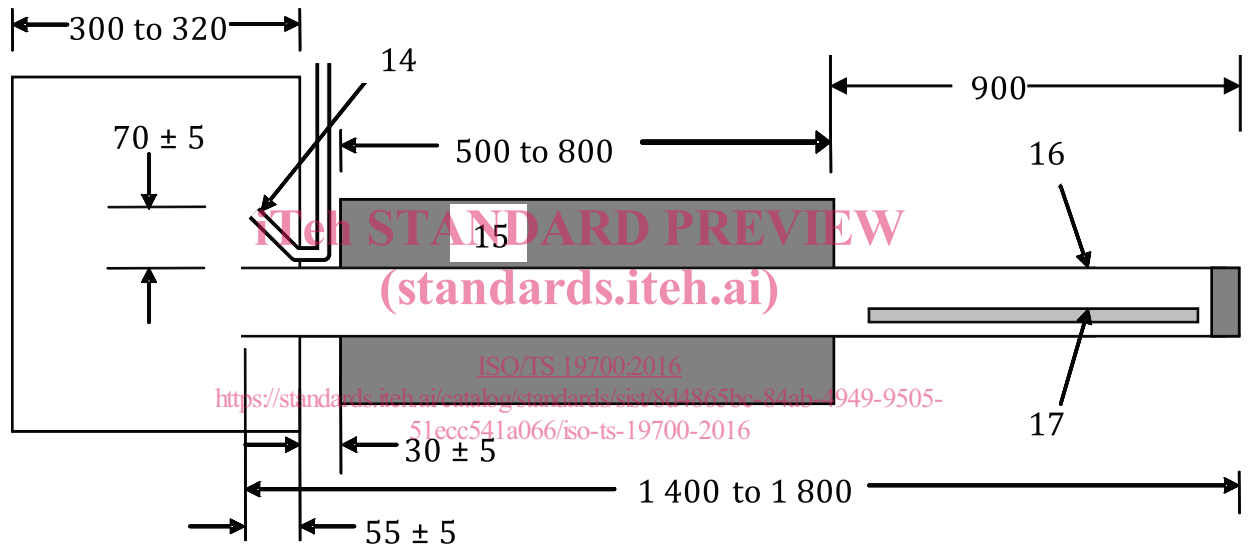

b) Critical dimensions of assembly

**Key**

- |                                   |  |
|-----------------------------------|--|
| 1 tube furnace                    | 10 light source (see Annex E)                        |
| 2 quartz furnace tube             | 11 photodetector (see Annex E)                       |
| 3 combustion boat                 | 12 gas bubblers (optional gas sampling method)       |
| 4 combustion boat drive mechanism | 13 pump with flow meter (optional, for gas bubblers) |
| 5 mixing and measurement chamber  | 14 secondary air inlet 45° to vertical               |
| 6 primary air inlet               | 15 tube furnace                                      |
| 7 secondary air inlet             | 16 furnace tube                                      |
| 8 ports for sampling lines        | 17 combustion boat 800 mm long                       |
| 9 smoke-particle filter           |  |

**Figure 1 — Tube-furnace decomposition and sampling apparatus**

### 5.3 Calibrated thermocouples

Calibrated stainless-steel sheathed thermocouples,  $(1,5 \pm 0,1)$  mm in diameter, shall be used for measuring the temperature in the furnace tube, the temperature in the mixing and measurement chamber and for calibrating the furnace.

### 5.4 Quartz furnace tube

The quartz furnace tube, as shown in [Figure 2](#), is made of clear heat-resistant quartz, resistant to the effects of fire effluent. The tube shall be long enough to accommodate the combustion boat outside the furnace, to pass through the furnace and protrude into the mixing and measurement chamber at the far end of the furnace. The tube shall therefore be at least (furnace length + 895 mm) in length. It has an external, approximately concentric diameter of  $(47,5 \pm 1)$  mm and a wall thickness of  $(2 \pm 0,5)$  mm. The outside diameter shall permit a smooth fit within the tube furnace ([5.2](#)) and allow expansion at operating temperatures.

The input end of the furnace tube shall have a closure with openings in it to allow the primary air inlet and the combustion boat drive to pass through while maintaining a leak-proof seal.

NOTE 1 A polytetrafluoroethylene (PTFE) gland seal has been found to be suitable.

The downstream end of the furnace tube shall pass through a heat-resisting sealed gland and shall protrude  $55 \pm 5$  mm into the mixing and measurement chamber ([5.7](#)).

NOTE 2 A gland made from glass wool or from glass rope inside a metal collar has been found to be suitable.

The end of the furnace tube should be able to accommodate an airflow restrictor reducing the outlet diameter of the quartz furnace tube to the mixing and measurement chamber to a maximum area of  $100 \text{ mm}^2$ . This prevents air from the mixing chamber diffusing back to the furnace tube at low primary airflows.

NOTE 3 A suitable flow restrictor has been made using a  $100 \text{ cm}^3$  borosilicate glass laboratory beaker which fits snugly inside the furnace tube, with a 35 mm diameter circular hole cut into the base. The hole was cut with the beaker under water, using a low voltage "Dremel" drill and grinding bit.

The distance between the exit of the tubular furnace and the mixing and measurement chamber shall be  $(30 \pm 5)$  mm.

The quartz furnace tube shall be horizontal (within  $\pm 1$  mm in the vertical direction per metre along the furnace axis) to ensure that molten fuels cannot flow up or down the combustion boat during a run.

### 5.5 Combustion boat

The combustion boat, as shown in [Figure 2](#), is made from quartz tubing of diameter  $(41 \pm 1)$  mm, with a length of 800 mm and a wall thickness of  $(2 \pm 0,5)$  mm. The boat should be cleaned after each test.

NOTE 1 A suitable combustion boat has been made from quartz tubing with a nominal diameter of 41 mm. This was sliced in half along its axis to provide a semi-circular cross-section, nominally of 41 mm width, 18 mm depth and 800 mm length. Flat semi-circular quartz plates were fused onto each end.

NOTE 2 A boat diameter (41 mm) provides the maximum test specimen capacity.

A boat length of 800 mm has been found suitable for testing most materials. Where materials take a long time to reach steady-state burning, or where a steady-state period of longer than 5 min is required, longer boats may be used.

NOTE 3 A convenient method of cleaning both the boat and tube is to remove obvious residues mechanically, then heat in a furnace at  $1\ 000 \text{ }^\circ\text{C}$ , followed by washing in water to remove any inorganic residues.

## 5.6 Combustion boat drive

### 5.6.1 Mechanism

The combustion boat is connected to a notched drive bar, which passes through the gland seal (5.4) at the upstream end of the furnace tube, and connects to a drive mechanism. The drive mechanism advances the boat at a typical rate of  $(40 \pm 1) \text{ mm}\cdot\text{min}^{-1}$ . The drive mechanism shall allow different advance rates to be selected.

The capacity of the drive mechanism shall be sufficient to move the combustion boat at least 800 mm. This will move the front of the boat from the near end of the furnace all the way to the far end of the furnace, just allowing the rear end of the 800 mm boat to enter the furnace. The mechanism shall enable the boat to be rapidly retracted into the upstream, external part of the furnace tube at the end of the test run. This may be achieved manually after detaching the push rod from the drive mechanism.

A drive advance rate of  $40 \text{ mm}\cdot\text{min}^{-1}$  has been found suitable for most materials under most decomposition conditions. For some fast-burning or low-density materials, it has been found necessary to use advance rates of up to  $60 \text{ mm}\cdot\text{min}^{-1}$ . For tests involving specimens of uniform linear density, such as rods of material, the drive advance rate should be adjusted to give a fuel feed rate of  $1 \text{ g}\cdot\text{min}^{-1}$ .

### 5.6.2 Rate of specimen introduction

The rate of introduction of the combustion boat (in  $\text{mm}\cdot\text{min}^{-1}$ ) shall be determined by advancing the boat over a distance of  $(800 \pm 1) \text{ mm}$  and measuring the time taken. This is  $(1\,200 \pm 12) \text{ s}$  at an advance rate of  $(40 \pm 1) \text{ mm}\cdot\text{min}^{-1}$ . The most important criterion for this parameter is repeatability, which should be within  $\pm 1 \%$ . The actual advance rate may be up to 10 % higher or lower than the specified rate. The actual advance rate shall be measured to 1% accuracy and the specimen mass loading is adjusted to provide a mass feed rate equivalent to that specified (see 9.2 and 9.3).

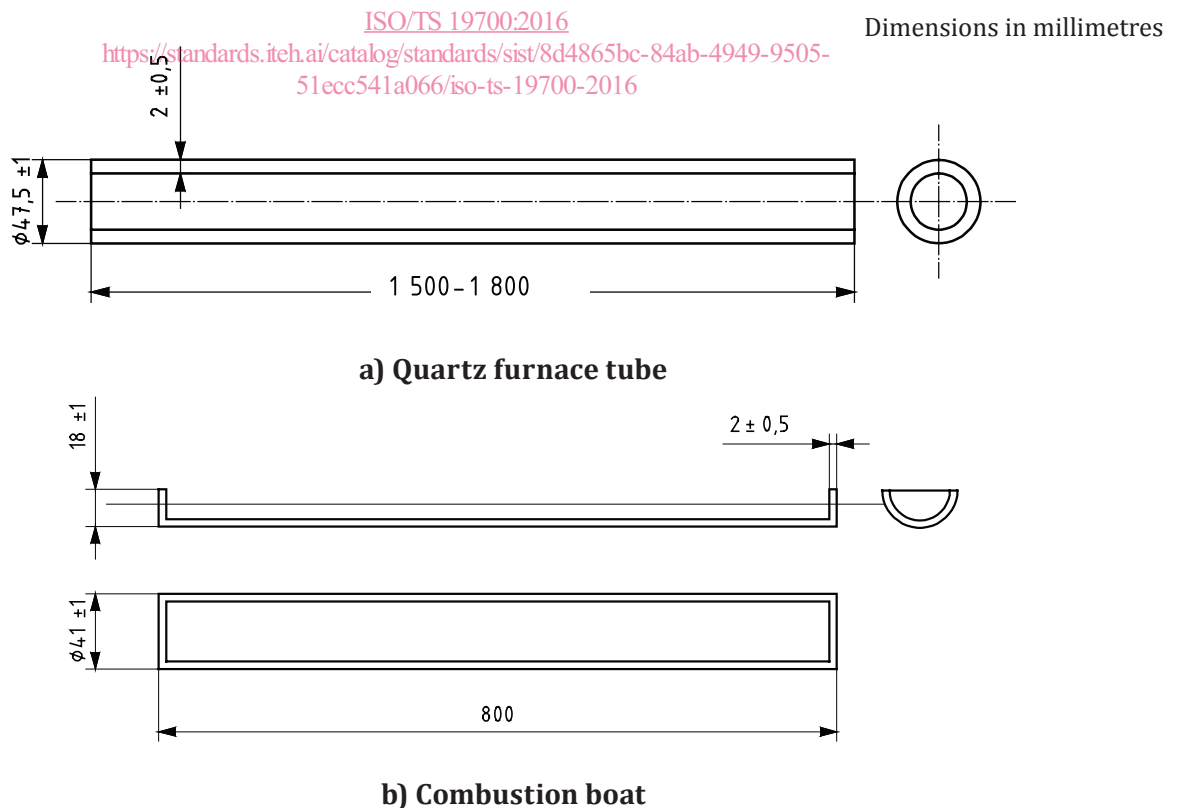

Figure 2 — Dimensions of a suitable quartz furnace tube and combustion boat

## 5.7 Mixing and measurement chamber

The mixing and measurement chamber shall be an approximately cubic box with a side length of  $(31 \pm 2)$  cm (see [Figure 3](#)), although the exact dimensions are not critical. The front of the chamber has a door, providing a seal when shut, but enabling cleaning of the chamber when open.

NOTE 1 The walls of the box can be made of any suitable material which has a low affinity for the analytes being quantified. Stainless steel coated with PTFE film, PMMA and polycarbonate have been found to be suitable materials. A suitable chamber can be made from a commercially available desiccator cabinet with nominal dimensions of 310 mm × 310 mm × 340 mm (see [Figure 3](#)). This would have an internal volume of 33 dm<sup>3</sup> compared with the airflow volume of 50 dm<sup>3</sup> in 1 min. For non-heat resistant wall materials (e.g. PMMA), the back wall of the chamber and the rear portion of the roof are protected by a stainless steel plate fitted to the inner surface, the top of the plate extending 140 mm across the chamber roof, so as to be resistant to heat and any flames emanating from the end of the furnace tube.

The volume of the mixing and measurement chamber needs to be large enough to accommodate the sampling points but smaller than the total volume of air flowing through the chamber in 1 min.

The roof of the chamber shall be fitted with a safety blow-out panel 75 mm in diameter, which will burst in the event of an explosion.

NOTE 2 This is important for safety reasons.

A port approximately 35 mm in diameter is provided at the base of the rear face of the chamber for the test atmosphere to be exhausted to waste.

The chamber shall include all the necessary sampling and measurement points (gas sampling probes to bubblers, etc., and particulate filters). Measurement points are located away from the rising plume and the chamber walls; these may be sited in any convenient location. The open end of each sample probe shall be  $(30 \pm 5)$  mm from the wall of the mixing and measurement chamber.

NOTE 3 The sampling points are positioned away from the furnace-tube exit plume and chamber walls but can be sited in any convenient location. Suitable locations are shown in [Figure 3](#).

NOTE 4 A thermocouple ([5.3](#)), extending approximately 50 mm into the mixing and measurement chamber, can be located as shown in [Figure 3](#), for monitoring of the temperature in the chamber during the tests.

## 5.8 Analysis of gases

This document requires the determination of certain combustion gases to characterize the fire condition. The means of gas sampling and analysis shall be those given in ISO 19701 and ISO 19702. The mixing chamber thermocouple shall be located in close proximity to the sampling port to ensure isothermal sampling conditions.

Carbon dioxide and oxygen concentrations shall be determined by continuous sampling throughout the test. These data are used to identify and monitor the steady-state burning period and also to characterize the fire condition. The concentration of carbon monoxide shall also be determined continuously.

The oxygen meter shall be capable of an accuracy of a volume fraction of 0,01 %.

The selection of toxic components of the fire effluent shall follow the appropriate hazard assessment, such as those set out in ISO 13344 or ISO 13571.

Further guidance is given in [10.4](#).

Dimensions in millimetres

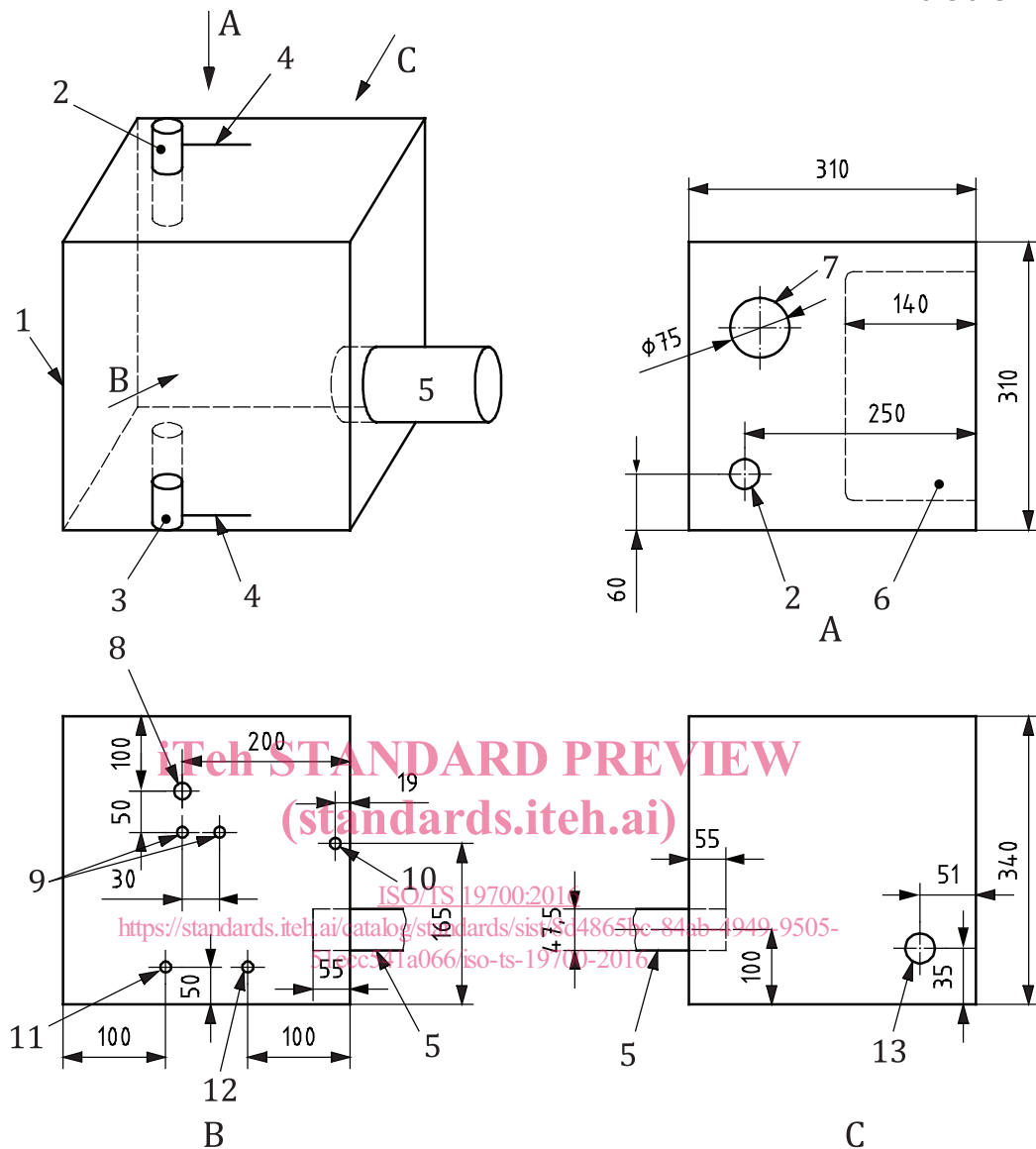

**Key**

- |  |   |
|--|---|
| 1 door   | 9 ports for sampling lines  |
| 2 tube containing photodetector (see Annex E)                  | 10 secondary air inlet  |
| 3 tube containing light source (see Annex E)                   | 11 port for thermocouple  |
| 4 purge tubes for photodetector and light source (see Annex E) | 12 port for tube to sample atmosphere in furnace tube for measurement of oxygen concentration |
| 5 quartz furnace tube  | 13 exhaust port   |
| 6 stainless-steel plate  | A top   |
| 7 safety blow-out panel  | B side-view   |
| 8 smoke particle filter  | C side-view   |

**Figure 3 — Dimensions of mixing and measurement chamber**