

---

---

**Road vehicles — Connectors for the  
electrical connection of towing and  
towed vehicles —**

Part 2:

**Connectors for braking systems and  
running gear of vehicles with 12 V  
nominal supply voltage**

iTeh STANDARD PREVIEW  
(standards.iteh.ai)

*Véhicules routiers — Connecteurs pour liaisons électriques entre  
véhicules tracteurs et véhicules tractés —*

<https://standards.iteh.ai/catalog/standards/sist/407a85c-71ef-4d72-8ed1-96a3b691b605/iso-7638-2-2018>

*Partie 2: Connecteurs pour les équipements de freinage et les organes  
de roulement des véhicules à tension nominale de 12 V*



**iTeh STANDARD PREVIEW**  
**(standards.iteh.ai)**

ISO 7638-2:2018

<https://standards.iteh.ai/catalog/standards/sist/407a8f5c-31e6-4d72-8edb-96a3b69cb605/iso-7638-2-2018>



**COPYRIGHT PROTECTED DOCUMENT**

© ISO 2018

All rights reserved. Unless otherwise specified, or required in the context of its implementation, no part of this publication may be reproduced or utilized otherwise in any form or by any means, electronic or mechanical, including photocopying, or posting on the internet or an intranet, without prior written permission. Permission can be requested from either ISO at the address below or ISO's member body in the country of the requester.

ISO copyright office  
CP 401 • Ch. de Blandonnet 8  
CH-1214 Vernier, Geneva  
Phone: +41 22 749 01 11  
Fax: +41 22 749 09 47  
Email: [copyright@iso.org](mailto:copyright@iso.org)  
Website: [www.iso.org](http://www.iso.org)

Published in Switzerland

# Contents

	Page
Foreword .....	iv
<b>1 Scope .....</b>	<b>1</b>
<b>2 Normative references .....</b>	<b>1</b>
<b>3 Terms and definitions .....</b>	<b>1</b>
4 Dimensional characteristics .....	1
4.1 General .....	1
4.2 Plug .....	2
4.3 Socket .....	2
4.4 Park socket .....	2
5 Application of the connector .....	2
5.1 General .....	2
5.2 Contact allocation .....	6
5.3 Contact designation .....	7
5.4 Terminals .....	7
5.5 Connecting cable .....	7
6 Tests and specific requirements .....	7
6.1 General .....	7
6.2 Mismatching .....	8
6.3 Connection and disconnection .....	8
6.4 Endurance .....	8

**ITeH STANDARD PREVIEW**  
(standards.iteh.ai)

[ISO 7638-2:2018](https://standards.iteh.ai/catalog/standards/sist/407a8f5c-31e6-4d72-8edb-96a3b69cb605/iso-7638-2-2018)

<https://standards.iteh.ai/catalog/standards/sist/407a8f5c-31e6-4d72-8edb-96a3b69cb605/iso-7638-2-2018>

## Foreword

ISO (the International Organization for Standardization) is a worldwide federation of national standards bodies (ISO member bodies). The work of preparing International Standards is normally carried out through ISO technical committees. Each member body interested in a subject for which a technical committee has been established has the right to be represented on that committee. International organizations, governmental and non-governmental, in liaison with ISO, also take part in the work. ISO collaborates closely with the International Electrotechnical Commission (IEC) on all matters of electrotechnical standardization.

The procedures used to develop this document and those intended for its further maintenance are described in the ISO/IEC Directives, Part 1. In particular the different approval criteria needed for the different types of ISO documents should be noted. This document was drafted in accordance with the editorial rules of the ISO/IEC Directives, Part 2 (see [www.iso.org/directives](http://www.iso.org/directives)).

Attention is drawn to the possibility that some of the elements of this document may be the subject of patent rights. ISO shall not be held responsible for identifying any or all such patent rights. Details of any patent rights identified during the development of the document will be in the Introduction and/or on the ISO list of patent declarations received (see [www.iso.org/patents](http://www.iso.org/patents)).

Any trade name used in this document is information given for the convenience of users and does not constitute an endorsement.

For an explanation on the voluntary nature of standards, the meaning of ISO specific terms and expressions related to conformity assessment, as well as information about ISO's adherence to the World Trade Organization (WTO) principles in the Technical Barriers to Trade (TBT) see the following URL: [www.iso.org/iso/foreword.html](http://www.iso.org/iso/foreword.html). (standards.iteh.ai)

This document was prepared by Technical Committee ISO/TC 22, *Road vehicles*, Subcommittee SC 32, *Electrical and electronic components and general system aspects*.

This third edition cancels and replaces the second edition (ISO 7638-2:2003), which has been technically revised. The main changes compared to the previous edition are as follows:

— corrected figures.

A list of all parts in the ISO 7638 series can be found on the ISO website.

# Road vehicles — Connectors for the electrical connection of towing and towed vehicles —

## Part 2:

# Connectors for braking systems and running gear of vehicles with 12 V nominal supply voltage

## 1 Scope

This part of ISO 7638 gives the dimensions of, and specifies the contact allocation and tests and test requirements for, connectors for the electrical connection of the braking systems and running gear of towing and towed vehicles with 12 V nominal supply voltage. In addition, it specifies a park socket used to receive and store the plug when disconnected.

## 2 Normative references

The following documents, in whole or in part, are normatively referenced in this document and are indispensable for its application. For dated references, only the edition cited applies. For undated references, the latest edition of the referenced document (including any amendments) applies.

ISO 4091, *Road vehicles — Connectors for the electrical connection of towing and towed vehicles — Definitions, tests and requirements* ISO 7638-2:2018

ISO 4141 (all parts), *Road vehicles — Multi-core connecting cables* https://standards.iteh.ai/catalog/standards/sist/407a8f5c-31e6-4d72-8edb-96a3b69cb605/iso-7638-2-2018

ISO 7638-1, *Road vehicles — Connectors for the electrical connection of towing and towed vehicles — Part 2: Connectors for braking systems and running gear of vehicles with 12 V nominal supply voltage*

ISO 11992-1, *Road vehicles — Interchange of digital information on electrical connections between towing and towed vehicles — Part 1: Physical layer and data-link layer*

ISO 11992-2, *Road vehicles — Interchange of digital information on electrical connections between towing and towed vehicles — Part 2: Application layer for brakes and running gear*

ISO 12098, *Road vehicles — Connectors for the electrical connection of towing and towed vehicles — 15 pole connector for vehicles with 24 V nominal supply voltage*

## 3 Terms and definitions

For the purposes of this document, the terms and definitions given in ISO 4091 apply.

ISO and IEC maintain terminological databases for use in standardization at the following addresses:

- IEC Electropedia: available at <http://www.electropedia.org/>
- ISO Online browsing platform: available at <https://www.iso.org/obp>

## 4 Dimensional characteristics

### 4.1 General

Details not specified are at the manufacturer's discretion.

The contacts shall be floating and shall align to the datum position when plug and socket are engaged.

#### 4.2 Plug

Dimensions of the plug shall be in accordance with [Figure 1](#). The locking lever design shall take into consideration the space required for screws used to fasten the socket (see [Figure 2](#)).

#### 4.3 Socket

Dimensions of the socket shall be in accordance with [Figure 2](#). The cover is shown in the open position: it shall close automatically when the plug is disconnected.

#### 4.4 Park socket

Dimensions of the park socket shall be in accordance with [Figure 3](#). The cover is shown in the open position: it shall close automatically when the plug is disconnected.

### 5 Application of the connector

#### 5.1 General

The coiled cable assembly is fitted to the semi-trailer towing vehicle (fifth wheel tractor) and may be connected to the electrical on-board network of the towing vehicle with or without the connection (see [Figure 4](#)).

The uncoiled cable assembly is fitted to the drawbar trailer. Therefore, the trailer towing vehicle (drawbar tractor) shall be fitted with a socket mounted at the rear of the vehicle (see [Figure 4](#)).

ISO 7638-2:2018  
<https://standards.iteh.ai/catalog/standards/sist/407a8f5c-31e6-4d72-8edb-96a3b69cb605/iso-7638-2-2018>

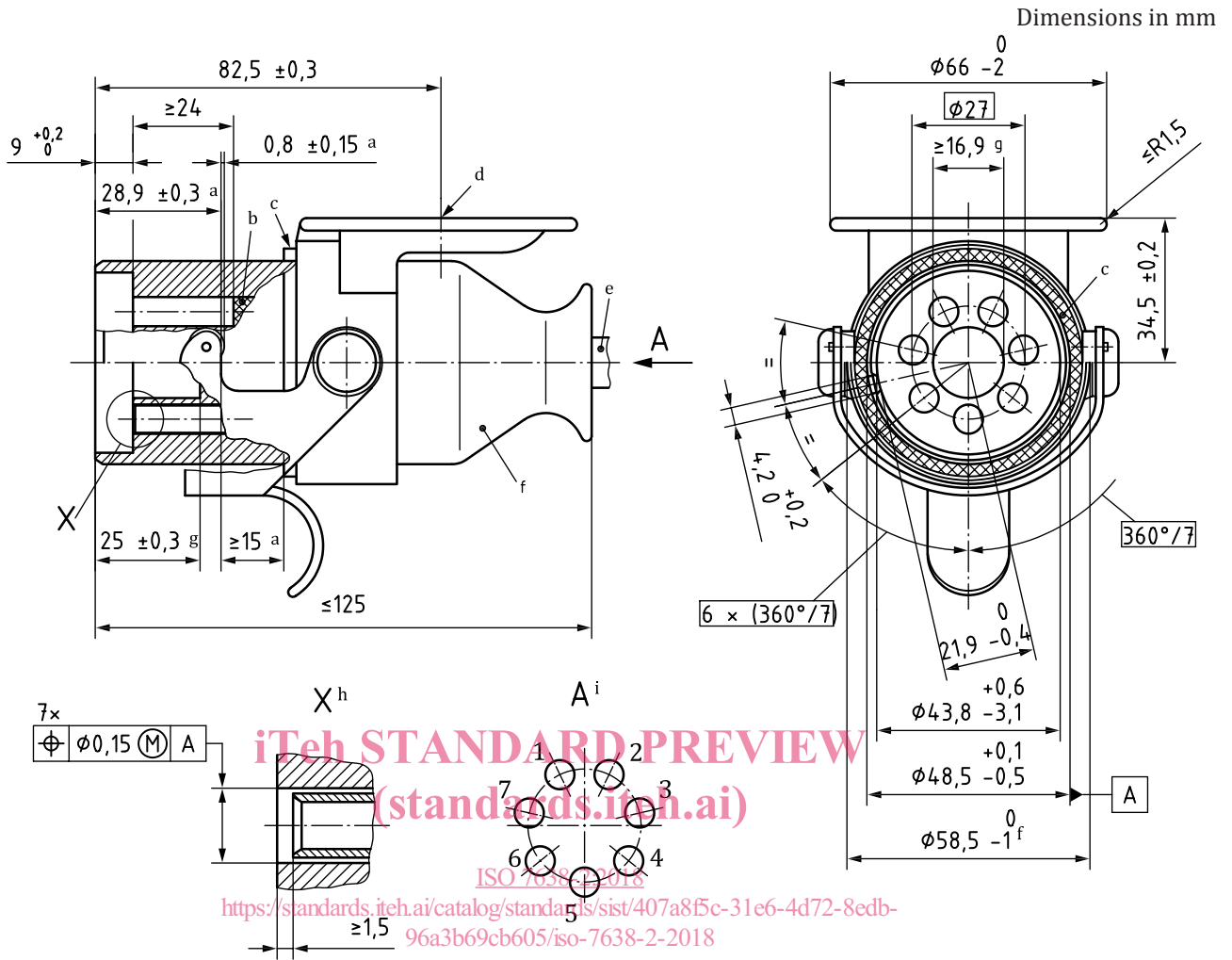

**Key**

- a Dimension refers to the locking lever in its locked position.
- b If contacts 6 and 7 are not used, blanking plugs shall, where applicable, be inserted to accept later fitment of pins and tubes. These blanks shall permit 5-pole versions to be mated with 7-pole versions.
- c The sealing ring shall be mounted such that it cannot become detached under normal use.
- d Centre of cover rest.
- e See ISO 4141-3.
- f Other housing designs are permitted provided they are in compliance with the maximum distance of 58 mm for the locking lever.
- g Minimum space required for the ejection from the socket.
- h Spring tube.
- i Contact numbers.

**Figure 1 — Plug**

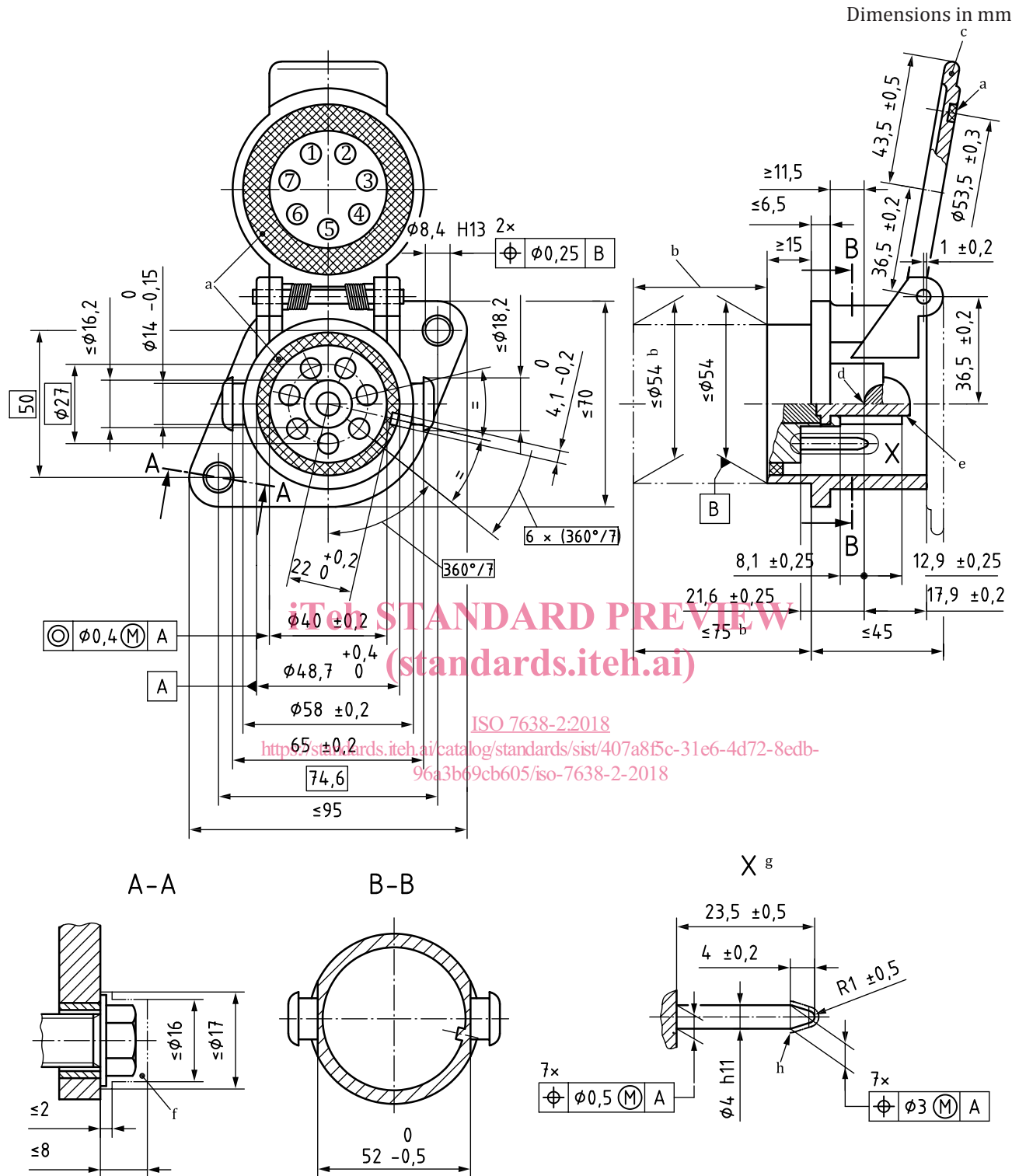

**Key**

- a The sealing ring shall be mounted such that it cannot become detached under normal use.
- b For existing products for which the cable outlet is mounted from the rear, the outside diameter of the outlet may be larger with the vehicle manufacturer's agreement. However, to ensure socket exchangeability, future applications should have a maximum outside diameter of 54 mm over a maximum length of 75 mm.
- c Opening angle  $\geq 120^\circ$ .
- d Reference point for engaged locking lever.
- e Ejector.
- f Minimum space required for screws used to fasten the socket.



- g If contacts 6 and 7 are not used, blanking plugs shall, where applicable, be inserted to accept later fitment of pins and tubes. These blanks shall permit 5-pole versions to be mated with 7-pole versions.
- h This area shall be smooth and burr-free.

Figure 2 — Socket

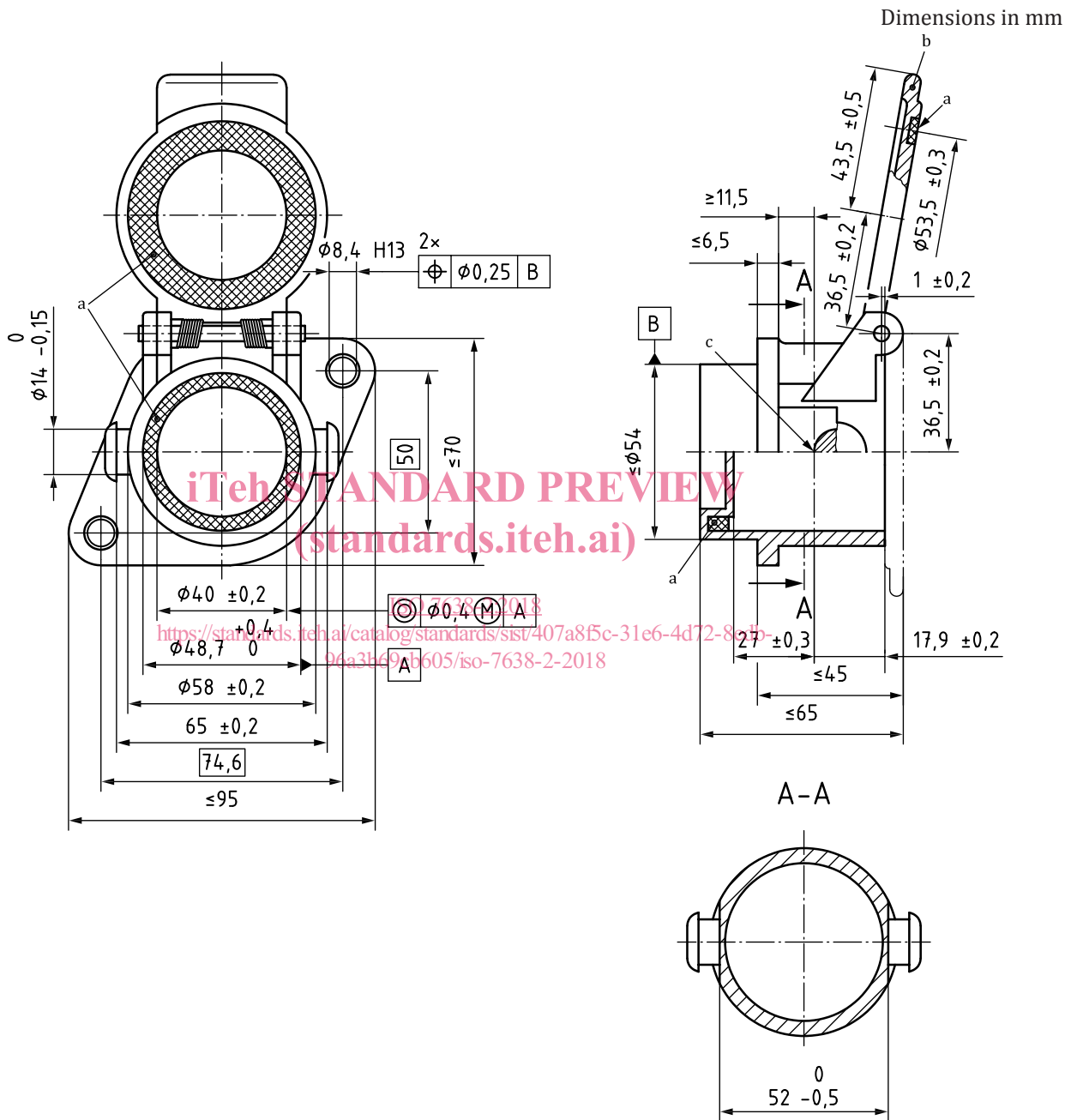

Key

- a The sealing ring shall be mounted such that it cannot become detached under normal use.
- b Opening angle  $\geq 120^\circ$ .
- c Reference point for engaged locking lever.

Figure 3 — Park socket