

---

---

**Liquid pumps and pumps units —  
Noise test code — Grades 2 and 3 of  
accuracy**

*Pompes et groupes motopompes pour liquides — Code d'essai  
acoustique — Classes de précision 2 et 3*

**iTeh STANDARD PREVIEW**  
**(standards.iteh.ai)**

[ISO 20361:2019](https://standards.iteh.ai/catalog/standards/sist/88956ac5-254d-4735-8b46-88679ca6a33b/iso-20361-2019)

<https://standards.iteh.ai/catalog/standards/sist/88956ac5-254d-4735-8b46-88679ca6a33b/iso-20361-2019>



## iTeh STANDARD PREVIEW (standards.iteh.ai)

ISO 20361:2019

<https://standards.iteh.ai/catalog/standards/sist/88956ac5-254d-4735-8b46-88679ca6a33b/iso-20361-2019>



### **COPYRIGHT PROTECTED DOCUMENT**

© ISO 2019

All rights reserved. Unless otherwise specified, or required in the context of its implementation, no part of this publication may be reproduced or utilized otherwise in any form or by any means, electronic or mechanical, including photocopying, or posting on the internet or an intranet, without prior written permission. Permission can be requested from either ISO at the address below or ISO's member body in the country of the requester.

ISO copyright office  
CP 401 • Ch. de Blandonnet 8  
CH-1214 Vernier, Geneva  
Phone: +41 22 749 01 11  
Fax: +41 22 749 09 47  
Email: [copyright@iso.org](mailto:copyright@iso.org)  
Website: [www.iso.org](http://www.iso.org)

Published in Switzerland

# Contents

	Page
<b>Foreword</b> .....	<b>iv</b>
<b>Introduction</b> .....	<b>v</b>
<b>1 Scope</b> .....	<b>1</b>
<b>2 Normative references</b> .....	<b>1</b>
<b>3 Terms and definitions</b> .....	<b>2</b>
<b>4 Pump family and pump configuration</b> .....	<b>2</b>
<b>5 Sound power level determination</b> .....	<b>2</b>
5.1 General.....	2
5.2 Specific considerations for reference box, measurement surface, position of microphones, and intensity probe.....	4
5.2.1 General.....	4
5.2.2 Reference box.....	5
5.2.3 Measurement surface and microphone positions.....	6
5.2.4 Position of microphones and intensity probes.....	10
<b>6 Emission sound pressure level determination</b> .....	<b>10</b>
6.1 Basic standard to be used.....	10
6.2 Relevant work station.....	10
<b>7 Uncertainty</b> .....	<b>10</b>
<b>8 Installation and mounting conditions</b> .....	<b>11</b>
8.1 General.....	11
8.2 Noise test situation.....	11
8.2.1 General.....	11
8.2.2 Test on site.....	12
8.2.3 Test on shop test stand.....	12
8.2.4 Test on a specific facility intended for acoustic measurement.....	12
<b>9 Operating conditions during noise measurement</b> .....	<b>12</b>
9.1 General.....	12
9.2 Pumped liquid.....	13
9.3 NPSHA value.....	13
<b>10 Information to be recorded and to be reported</b> .....	<b>13</b>
10.1 General.....	13
10.2 Test report.....	13
<b>11 Declaration and verification of noise emission values</b> .....	<b>14</b>
<b>Annex A (normative) Pump alone — Measurement surface</b> .....	<b>15</b>
<b>Annex B (normative) Pump units — Microphone positions for sound pressure level measurement on the measurement surface for different pump types and sizes</b> .....	<b>16</b>
<b>Annex C (informative) Example of a dual-number noise declaration</b> .....	<b>23</b>
<b>Bibliography</b> .....	<b>24</b>

## Foreword

ISO (the International Organization for Standardization) is a worldwide federation of national standards bodies (ISO member bodies). The work of preparing International Standards is normally carried out through ISO technical committees. Each member body interested in a subject for which a technical committee has been established has the right to be represented on that committee. International organizations, governmental and non-governmental, in liaison with ISO, also take part in the work. ISO collaborates closely with the International Electrotechnical Commission (IEC) on all matters of electrotechnical standardization.

The procedures used to develop this document and those intended for its further maintenance are described in the ISO/IEC Directives, Part 1. In particular, the different approval criteria needed for the different types of ISO documents should be noted. This document was drafted in accordance with the editorial rules of the ISO/IEC Directives, Part 2 (see [www.iso.org/directives](http://www.iso.org/directives)).

Attention is drawn to the possibility that some of the elements of this document may be the subject of patent rights. ISO shall not be held responsible for identifying any or all such patent rights. Details of any patent rights identified during the development of the document will be in the Introduction and/or on the ISO list of patent declarations received (see [www.iso.org/patents](http://www.iso.org/patents)).

Any trade name used in this document is information given for the convenience of users and does not constitute an endorsement.

For an explanation of the voluntary nature of standards, the meaning of ISO specific terms and expressions related to conformity assessment, as well as information about ISO's adherence to the World Trade Organization (WTO) principles in the Technical Barriers to Trade (TBT), see [www.iso.org/iso/foreword.html](http://www.iso.org/iso/foreword.html).

This document was prepared by the European Committee for Standardization (CEN) Technical Committee CEN/TC 197, *Pumps*, in collaboration with ISO Technical Committee TC 115, *Pumps*, in accordance with the agreement on technical cooperation between ISO and CEN (Vienna Agreement).

This third edition cancels and replaces the second edition (ISO 20361:2015), which has been technically revised. The main changes compared to the previous edition are as follows:

- addition of [Clause 7](#) on measurement uncertainty;
- addition of information in [Clause 8](#) on noise test situation and background noise;
- change of title of previous [Clause 9](#) (now [Clause 10](#)).

Any feedback or questions on this document should be directed to the user's national standards body. A complete listing of these bodies can be found at [www.iso.org/members.html](http://www.iso.org/members.html).

## Introduction

The noise emitted by a pump unit can be radiated by the casing of the pump, the driving system (e.g. motor, gear box, coupling), the piping system, and all the connected structures.

On site, the perceived noise can be significantly increased by reverberation effects or by the radiation of extraneous sources.

Depending on the type of pump it can be useful to know the following:

- a) the noise of the pumping system (including piping);
- b) the noise of the pump unit, including the driver and the transmission elements but excluding the noise of the piping system;
- c) the noise emitted by the pump alone, excluding the noise from the driver, transmission elements, and the piping;
- d) the noise emitted by each of those elements in respect to a given requirement or in view of an efficient sound proofing of the installation.

This document describes methods for the determination of the noise emitted by a pump unit [case b)] or a pump alone [case c)]. Noise emission is expressed in terms of the sound power level of the machine and the emission sound pressure level at the relevant work station (see 6.2).

This document is intended to enable the manufacturer to

- show the effectiveness of noise reduction, and
- declare the noise emission levels.

This document is a type-C standard as stated in ISO 12100.

This document is of relevance, in particular, for the following stakeholder groups representing the market players with regard to machinery safety:

- machine manufacturers (small, medium and large enterprises);
- health and safety bodies (regulators, accident prevention organizations, market surveillance, etc.).

Others can be affected by the level of machinery safety achieved with the means of the document by the above-mentioned stakeholder groups:

- machine users/employers (small, medium and large enterprises);
- machine users/employees (e.g. trade unions, organizations for people with special needs);
- service providers, e.g. for maintenance (small, medium and large enterprises);
- consumers (in case of machinery intended for use by consumers).

The above-mentioned stakeholder groups have been given the possibility to participate at the drafting process of this document. The machinery concerned and the extent to which hazards, hazardous situations or hazardous events are covered are indicated in the Scope of this document.

When requirements of this type-C standard are different from those which are stated in type-A or type-B standards, the requirements of this type-C standard take precedence over the requirements of the other standards for machines that have been designed and built according to the requirements of this type-C standard.

The machinery concerned and the extent to which noise is covered are indicated in the scope of this document.

**iTeh STANDARD PREVIEW**  
**(standards.iteh.ai)**

ISO 20361:2019

<https://standards.iteh.ai/catalog/standards/sist/88956ac5-254d-4735-8b46-88679ca6a33b/iso-20361-2019>

# Liquid pumps and pumps units — Noise test code — Grades 2 and 3 of accuracy

## 1 Scope

This document specifies all the information necessary to carry out efficiently and under standardized conditions the determination, declaration, and verification of the airborne noise emission of liquid pumps or pump units (see 4.1). It specifies the noise measurement methods and the operating and mounting conditions that shall be used for the test.

Noise emission characteristics include emission sound pressure levels at specified positions and the sound power level. The determination of these quantities is necessary for

- declaring the noise emission values, and
- purpose of noise control at source at the design stage.

The determination of these quantities is also necessary for comparing the noise emitted by liquid pumps on the market.

The use of this document ensures the reproducibility of the determination of the airborne noise-emission characteristics within specified limits determined by the grade of accuracy of the basic airborne noise measurement method used. Noise measurement methods according to this document are engineering methods (grade 2) and survey methods (grade 3).

This document does not deal with the characterization of the structure-borne sound and liquid-borne noise generated by liquid pumps.

NOTE This document is specified in EN 809+A1 for noise measurements of the pump (or pump unit).

## 2 Normative references

The following documents are referred to in the text in such a way that some or all of their content constitutes requirements of this document. For dated references, only the edition cited applies. For undated references, the latest edition of the referenced document (including any amendments) applies.

ISO 3743-1:2010, *Acoustics — Determination of sound power levels and sound energy levels of noise sources using sound pressure — Engineering methods for small movable sources in reverberant fields — Part 1: Comparison method for a hard-walled test room*

ISO 3743-2:2018, *Acoustics — Determination of sound power levels of noise sources using sound pressure — Engineering methods for small, movable sources in reverberant fields — Part 2: Methods for special reverberation test rooms*

ISO 3744:2010, *Acoustics — Determination of sound power levels and sound energy levels of noise sources using sound pressure — Engineering methods for an essentially free field over a reflecting plane*

ISO 3746:2010, *Acoustics — Determination of sound power levels and sound energy levels of noise sources using sound pressure — Survey method using an enveloping measurement surface over a reflecting plane*

ISO 4871:1996, *Acoustics — Declaration and verification of noise emission values of machinery and equipment*

ISO 9614-1:1993, *Acoustics — Determination of sound power levels of noise sources using sound intensity — Part 1: Measurement at discrete points*

## ISO 20361:2019(E)

ISO 9614-2:1996, *Acoustics — Determination of sound power levels of noise sources using sound intensity — Part 2: Measurement by scanning*

ISO 11203:1995, *Acoustics — Noise emitted by machinery and equipment — Determination of emission sound pressure levels at a work station and at other specified positions from the sound power level*

ISO 17769-1:2012, *Liquid pumps and installation — General terms — Definitions, quantities, letter symbols and units*

ISO 17769-2:2012, *Liquid pumps and installation — General terms — Definitions, quantities, letter symbols and units*

### 3 Terms and definitions

For the purposes of this document, the terms and definitions given in ISO 17769-1, ISO 17769-2 and the following apply.

ISO and IEC maintain terminological databases for use in standardization at the following addresses:

- ISO Online browsing platform: available at <https://www.iso.org/obp>
- IEC Electropedia: available at <http://www.electropedia.org/>

#### 3.1

##### **pump**

equipment that is defined as being terminated by its inlet and outlet branches as well as in general its shaft ends

#### 3.2

##### **pump unit**

equipment that is comprised of the *pump* (3.1) and its driver (e.g. electric motor, steam turbine) including transmission elements (e.g. coupling gear), baseplates, and any auxiliary equipment supplied with the pump

### 4 Pump family and pump configuration

4.1 Pumps covered by this document comprise of liquid pumps of the rotodynamic and positive displacement, rotary, and reciprocating types.

4.2 This document provides two possibilities of measurement, either pump alone (see [Table 1](#)) or pump units (see [Table 2](#)). In these two cases, the pumps shall be installed

- on site (see [8.2.2](#)), or
- on shop test stand (see [8.2.3](#)), or
- in a specific facility intended for acoustic measurement (see [8.2.4](#)).

4.3 Safety guards, e.g. coupling guards, insulation hoods, etc., if any, shall be installed during noise-emission determination.

### 5 Sound power level determination

#### 5.1 General

One of the following grade 2 of accuracy methods for determining the sound power level shall be used:

- ISO 3743-1 or ISO 3743-2;



NOTE 1 ISO 3743-1 is based upon a hard-walled room and low background noise. This document gives specifications to sound pressure level measurement in octave bands in order to calculate the sound power level.

NOTE 2 ISO 3743-2 is based upon special reverberation test room. This document gives specifications to sound pressure measurement in octave bands or overall A-weighted sound pressure level measurement in order to calculate the sound power level.

— ISO 3744;

NOTE 3 ISO 3744 is based upon a non-reverberant environment and low background noise. This document specifies a method to calculate the sound power level from the measured A-weighted sound pressure levels, or sound pressure levels in octave or third octave bands.

— ISO 9614-1 or ISO 9614-2.

If it has been shown that the applicability requirements of these grade 2 standards cannot be attained, e.g. too much background noise, then one of the following grade 3 methods shall be used:

— ISO 3746;

NOTE 4 ISO 3746 is less demanding, it only gives specifications to the measurement of A-weighted sound pressure levels and provides A-weighted sound power levels with grade 3 of accuracy.

— ISO 9614-1 or ISO 9614-2;

NOTE 5 ISO 9614 (all parts) can be used in all environments, including reverberation and extraneous noise sources to a large extent. This document gives specifications to sound intensity and sound pressure measurement. Depending on the level of the reverberation and extraneous noise, it provides the sound power level either as A-weighted overall level or in octave or third-octave band. For grade 3 measurements, only the overall A-weighted sound power level is available.

NOTE 6 ISO 9614-1 requires measurements of sound intensity and simultaneously sound pressure level (at discrete points). In this case, the number of points is generally higher than the number of points used for the standards based on sound pressure measurements.

NOTE 7 ISO 9614-2 requires measurement of sound intensity and simultaneously sound pressure level by scanning. This can be made on partial or global surface depending on the configuration of the machine. The method generally reduces the measurement time.

— ISO/TS 7849-1 or ISO/TS 7849-2.

NOTE 8 ISO/TS 7849 (both parts) are Technical Specifications that can be used only when the prescriptions of the other methods are not fulfilled. These methods are based upon measurement of vibration velocity of the relevant parts of the pump or pump unit. ISO/TS 7849-1 provides an estimation (upper limit) of the A-weighted sound power level and ISO/TS 7849-2 provides the A-weighted sound power level or sound power level in octave or third octave bands.

For selection of the basic International Standard for determination of the sound power level of a pump, [Table 1](#) for pumps (pump alone) and [Table 2](#) for pump units shall be used.

The reflecting plane shall be either a hard plane or a surface of water.

The International Standard, indicated in bold letters in [Tables 1](#) and [2](#), describes the preferred method and shall be used where practical. If it is not practical, one of the other noted basic International Standards shall be used.

**Table 1 — Pumps (pump alone) — Selection of International Standards for determination of sound power level**

Test arrangement	Grade	Pump power input $P$ kW			
		$0,5 < P \leq 15$	$15 < P \leq 75$	$75 < P \leq 300$	$P > 300$
Specific facility <sup>a</sup>	2	ISO 3744 ISO 3743-2 ISO 9614 <sup>b</sup>	ISO 9614 <sup>b</sup> ISO 3744 ISO 3743-2	ISO 9614 <sup>b</sup> ISO 3744	ISO 9614 <sup>b</sup> ISO 3744
Shop test stand	2	ISO 9614 <sup>b</sup>			impractical
	3	ISO 9614 <sup>b</sup> ISO 3746		ISO 9614 <sup>b</sup>	
On site	2	ISO 9614 <sup>b</sup>			impractical
	3	ISO 9614 <sup>b</sup> ISO 3746		ISO 9614 <sup>b</sup> ISO/TR 7849	

<sup>a</sup> A facility can be qualified as specifically designed for noise measurements if it yields grade 2 measurements.  
<sup>b</sup> ISO 9614 means ISO 9614-1 or ISO 9614-2.

**Table 2 — Pump unit — Selection of standards for determination of sound power level**

Test arrangement	Grade	Pump power input $P$ kW			
		$0,5 < P \leq 15$	$15 < P \leq 75$	$75 < P \leq 300$	$P > 300$
Specific facility <sup>a</sup>	2	ISO 3744 ISO 3743-2 ISO 9614 <sup>b</sup>	ISO 3744 ISO 9614 <sup>b</sup>	ISO 9614 <sup>b</sup> ISO 3744	ISO 9614 <sup>b</sup> ISO 3744
Shop test stand	2	ISO 3744 ISO 3743-1 <sup>c</sup> ISO 9614 <sup>b</sup>	ISO 3744 ISO 9614 <sup>b</sup>	ISO 9614 <sup>b</sup> ISO 3744	ISO 9614 <sup>b</sup>
	3	ISO 3746 ISO 9614 <sup>b</sup>		ISO 9614 <sup>b</sup> ISO 3746	ISO 9614 <sup>b</sup> ISO 3746
On site	2	ISO 9614 <sup>b</sup> ISO 3744			ISO 9614 <sup>b</sup>
	3	ISO 3746 ISO 9614 <sup>b</sup>		ISO 9614 <sup>b</sup> ISO 3746	

<sup>a</sup> A facility can be qualified as specifically designed for noise measurements if it yields grade 2 measurements.  
<sup>b</sup> ISO 9614 means ISO 9614-1 or ISO 9614-2.  
<sup>c</sup> ISO 3743-1 can be used for pump units in a shop test stand at the condition that pipings are properly lagged.

## 5.2 Specific considerations for reference box, measurement surface, position of microphones, and intensity probe

### 5.2.1 General

When ISO 3744, ISO 3746, or ISO 9614 is used, 5.2.2 to 5.2.4 apply.

### 5.2.2 Reference box

The reference box is a hypothetical surface, the smallest simple volume (parallelepiped, box, cylinder, etc.) containing the pump unit or pump and the flanges of the machine but excluding the pipings for the pump unit and pipings, transmission elements, and driver for pumps (pump alone) and small individual components of the source that do not contribute to the sound radiation. For ISO 3744 and ISO 3746, the reference box is a parallelepiped. The box encloses the source and terminates on the reflecting plane (hard ground or water). For examples of reference boxes, see [Figures 1](#) and [2](#).

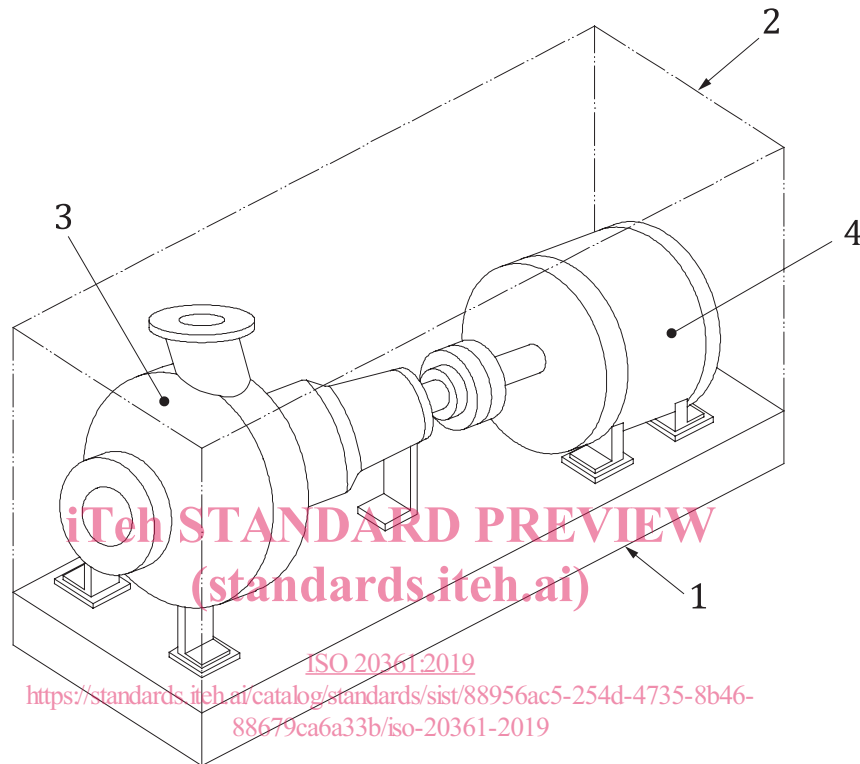

#### Key

- 1 reflecting plane
- 2 reference box
- 3 pump
- 4 driver

**Figure 1 — Reference box for pump unit (example)**

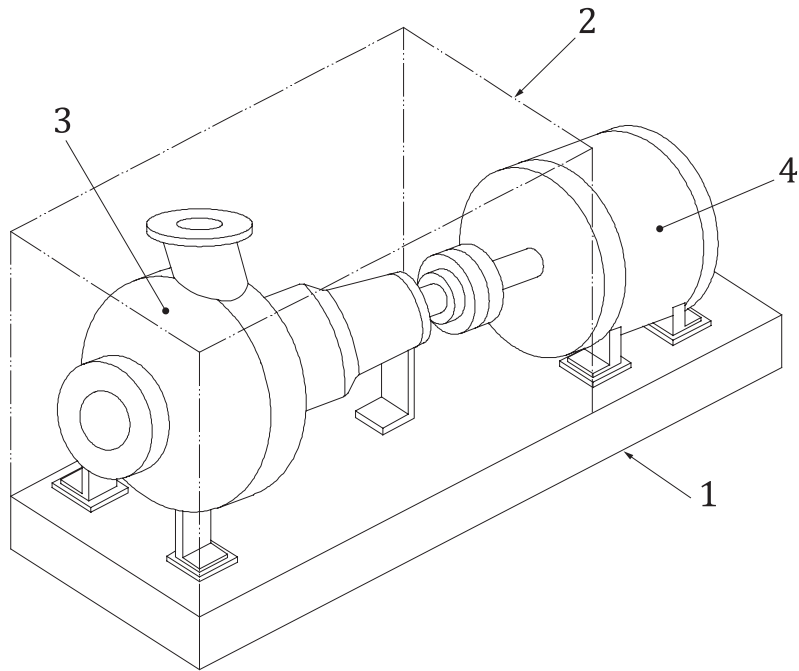

- Key**
- 1 reflecting plane
  - 2 reference box
  - 3 pump
  - 4 driver

**iTeh STANDARD PREVIEW**  
(standards.iteh.ai)

**Figure 2 — Reference box for pump (alone) (example)**  
ISO 20361:2019  
<https://standards.iteh.ai/catalog/standards/sist/88956ac5-254d-4735-8b46-88679ca6a33b/iso-20361-2019>

**5.2.3 Measurement surface and microphone positions**

The measurement surface is a surface enveloping the reference box at a given distance to the box.

The distance between the measurement surface and the reference box is called the measurement distance. It depends on the basic method used.

- For ISO 3744 and ISO 3746, both of which are based on sound pressure level measurements, the distance shall be chosen equal to 1 m.

Where the background noise requirements of these International Standards are not met, a distance smaller than 1 m but larger than 0,25 m can be chosen.

- For ISO 9614-1 and ISO 9614-2, both of which are based on a sound intensity measurement, the distance shall be
  - $d_1 \geq 0,5$  m for ISO 9614-1;
  - $0,2 \text{ m} \leq d_2 \leq 0,5$  m for ISO 9614-2.

For the measurement surface, see [Figures 3](#) to [6](#).

Reference shall also be made to [Annex A](#).