



# SLOVENSKI STANDARD

## SIST EN 15567-1:2015+A1:2020

01-maj-2020

Nadomešča:  
SIST EN 15567-1:2015

---

**Športni in rekreacijski pripomočki - Vrvni plezalni parki - 1. del: Konstrukcijske in varnostne zahteve**

Sports and recreational facilities - Ropes courses - Part 1: Construction and safety requirements

Sport- und Freizeitanlagen - Seilgärten - Teil 1: Konstruktion und sicherheitstechnische Anforderungen

(standards.iteh.ai)

Structures de sport et d'activités de plein air - Parcours acrobatiques en hauteur - Partie 1 : Exigences de construction et de sécurité

<https://standards.iteh.ai/catalog/standards/sist/5119f1fd-45f1-4ce7-967c-98318e8d3ffd/sist-en-15567-1-2015a1-2020>

**Ta slovenski standard je istoveten z: EN 15567-1:2015+A1:2020**

---

**ICS:**

97.220.10      Športni objekti                      Sports facilities

**SIST EN 15567-1:2015+A1:2020                      en,fr,de**

**iTeh STANDARD PREVIEW**  
**(standards.iteh.ai)**

[SIST EN 15567-1:2015+A1:2020](https://standards.iteh.ai/catalog/standards/sist/5119f1fd-45f1-4ce7-967c-98318e8d3ffd/sist-en-15567-1-2015a1-2020)

<https://standards.iteh.ai/catalog/standards/sist/5119f1fd-45f1-4ce7-967c-98318e8d3ffd/sist-en-15567-1-2015a1-2020>

EUROPEAN STANDARD

EN 15567-1:2015+A1

NORME EUROPÉENNE

EUROPÄISCHE NORM

February 2020

ICS 97.220.10

Supersedes EN 15567-1:2015

English Version

## Sports and recreational facilities - Ropes courses - Part 1: Construction and safety requirements

Structures de sport et d'activités de plein air - Parcours  
acrobatiques en hauteur - Partie 1 : Exigences de  
construction et de sécurité

Sport- und Freizeitanlagen - Seilgärten - Teil 1:  
Konstruktion und sicherheitstechnische  
Anforderungen

This European Standard was approved by CEN on 12 March 2015 and includes Amendment 1 approved by CEN on 11 November 2019.

CEN members are bound to comply with the CEN/CENELEC Internal Regulations which stipulate the conditions for giving this European Standard the status of a national standard without any alteration. Up-to-date lists and bibliographical references concerning such national standards may be obtained on application to the CEN-CENELEC Management Centre or to any CEN member.

This European Standard exists in three official versions (English, French, German). A version in any other language made by translation under the responsibility of a CEN member into its own language and notified to the CEN-CENELEC Management Centre has the same status as the official versions.

CEN members are the national standards bodies of Austria, Belgium, Bulgaria, Croatia, Cyprus, Czech Republic, Denmark, Estonia, Finland, France, Germany, Greece, Hungary, Iceland, Ireland, Italy, Latvia, Lithuania, Luxembourg, Malta, Netherlands, Norway, Poland, Portugal, Republic of North Macedonia, Romania, Serbia, Slovakia, Slovenia, Spain, Sweden, Switzerland, Turkey and United Kingdom.



EUROPEAN COMMITTEE FOR STANDARDIZATION  
COMITÉ EUROPÉEN DE NORMALISATION  
EUROPÄISCHES KOMITEE FÜR NORMUNG

CEN-CENELEC Management Centre: Rue de la Science 23, B-1040 Brussels

<b>Contents</b>	<b>Page</b>
European foreword.....	3
Introduction .....	5
1 Scope.....	6
2 Normative references.....	6
3 Terms and definitions .....	7
4 Safety requirements.....	12
4.1 Choice of site .....	12
4.2 Material.....	13
4.3 Design and manufacture.....	16
4.4 Personal protective equipment (PPE).....	22
5 Test methods .....	23
6 Marking.....	23
6.1 Element identification.....	23
6.2 Element marking.....	23
7 Inspection and maintenance.....	24
7.1 Inspection .....	24
7.2 Maintenance manual.....	25
8 Documents.....	26
8.1 General.....	26
8.2 User manual for operators.....	26
8.3 Arboreal assessment report.....	27
Annex A (normative) Minimum information to be included in an arboreal assessment report.....	28
Annex B (normative) Instructions for the use of the ropes course.....	29
Annex C (informative) Relevance of ISO 4309:2010 to EN 15567-1 for Ropes Courses.....	31
Annex D (informative) Guidance on risk assessment.....	36
Bibliography.....	37

## European foreword

This document (EN 15567-1:2015+A1:2020) has been prepared by Technical Committee CEN/TC 136 “Sports, playground and other recreational facilities and equipment”, the secretariat of which is held by DIN.

This European Standard shall be given the status of a national standard, either by publication of an identical text or by endorsement, at the latest by August 2020, and conflicting national standards shall be withdrawn at the latest by August 2020.

Attention is drawn to the possibility that some of the elements of this document may be the subject of patent rights. CEN shall not be held responsible for identifying any or all such patent rights.

This document includes amendment 1, approved by CEN on 11 November 2019.

This document supersedes <sup>A1</sup> EN 15567-1:2015. <sup>A1</sup>

The start and finish of text introduced or altered by amendment is indicated in the text by tags <sup>A1</sup> <sup>A1</sup>.

EN 15567 consists of the following parts, under the general title, *Sports- and recreational facilities — Ropes courses*:

— *Part 1: Construction and safety requirements;*

— *Part 2: Operation requirements.*

The main changes to EN 15567-1:2007 are:

- a) terms and definitions revised (Clause 3);
- b) requirements for wire ropes revised (4.2.4);
- c) new clause for synthetic ropes included (4.2.5);
- d) influence of loads revised (4.3.2);
- e) requirements for trees revised (4.3.3.3);
- f) requirements for zip lines revised (4.3.4.2);
- g) requirements for safety systems revised (4.3.5);
- h) requirements for personal protective equipment revised in accordance with existing standards (4.4);
- i) requirements for inspection and maintenance revised (Clause 7);
- j) Annex A revised;
- k) Annex B deleted;

**EN 15567-1:2015+A1:2020 (E)**

- l) new Annex C “Relevance of ISO 4309:2010 to EN 15567-1 for ropes courses” added;
- m) correction of editorial errors.

According to the CEN/CENELEC Internal Regulations, the national standards organizations of the following countries are bound to implement this European Standard: Austria, Belgium, Bulgaria, Croatia, Cyprus, Czech Republic, Denmark, Estonia, Finland, France, Germany, Greece, Hungary, Iceland, Ireland, Italy, Latvia, Lithuania, Luxembourg, Malta, Netherlands, Norway, Poland, Portugal, Republic of North Macedonia, Romania, Slovakia, Slovenia, Spain, Sweden, Switzerland, Turkey and the United Kingdom.

## **iTeh STANDARD PREVIEW** **(standards.iteh.ai)**

[SIST EN 15567-1:2015+A1:2020](https://standards.iteh.ai/catalog/standards/sist/5119f1fd-45f1-4ce7-967c-98318e8d3ffd/sist-en-15567-1-2015a1-2020)

<https://standards.iteh.ai/catalog/standards/sist/5119f1fd-45f1-4ce7-967c-98318e8d3ffd/sist-en-15567-1-2015a1-2020>

## Introduction

Ropes courses vary considerably and may be used for educational, recreational, training or therapeutic purposes.

Ropes course activities involve risks that should be managed by the manufacturers and operators. This is achieved through careful design, manufacture, supervision, training, instruction, information etc.

Ropes course activities should only be undertaken by those who are physically and mentally able to comply with the safety requirements specified by the operator.

The various safety devices (for protection against falling from a height and collisions) consist of equipment designed to limit the consequences of falls or collisions. There are inherent risks associated with ropes courses. These risks should, however, be appropriately managed and reduced to an acceptable level by the ropes course operator. However, it should be understood that such risks cannot be eliminated altogether. It should be noted that no safety system can prevent deliberate misuse.

On the basis of a risk assessment, that takes into account the manufacturer's manual, operators should take reasonably practicable measures to ensure the safety of participants and staff. This means that the degree of risks in a particular job/work place/facility need to be balanced against the time, trouble, cost, benefits and physical difficulty of taking measures to avoid or reduce the risk.

Ropes course operators should also consider EN 15567-2, when carrying out risk assessments.

## iTeh STANDARD PREVIEW (standards.iteh.ai)

[SIST EN 15567-1:2015+A1:2020](https://standards.iteh.ai/catalog/standards/sist/5119fffd-45ff-4ce7-967c-98318e8d3ffd/sist-en-15567-1-2015a1-2020)

<https://standards.iteh.ai/catalog/standards/sist/5119fffd-45ff-4ce7-967c-98318e8d3ffd/sist-en-15567-1-2015a1-2020>

**EN 15567-1:2015+A1:2020 (E)****1 Scope**

This European Standard applies to permanent and mobile ropes courses and their components.

This European Standard specifies safety requirements for the design, construction, inspection and maintenance of ropes courses and their components.

This European Standard does not apply to temporary ropes courses (see 3.3) and children's play grounds (see EN 1176 all parts).

For the use of ropes courses EN 15567-2 applies.

**2 Normative references**

The following documents, in whole or in part, are normatively referenced in this document and are indispensable for its application. For dated references, only the edition cited applies. For undated references, the latest edition of the referenced document (including any amendments) applies.

EN 335, *Durability of wood and wood-based products - Use classes: definitions, application to solid wood and wood-based products*

EN 350-2:1994, *Durability of wood and wood-based products — Natural durability of solid wood — Part 2: Guide to natural durability and treatability of selected wood species of importance in Europe*

EN 351-1:2007, *Durability of wood and wood-based products - Preservative-treated solid wood - Part 1: Classification of preservative penetration and retention*

EN 358, *Personal protective equipment for work positioning and prevention of falls from a height - Belts and lanyards for work positioning or restraint*

EN 361, *Personal protective equipment against falls from a height - Full body harnesses*

EN 636, *Plywood — Specifications*

EN 813, *Personal fall protection equipment - Sit harnesses*

EN 1176-1, *Playground equipment and surfacing - Part 1: General safety requirements and test methods*

EN 12277, *Mountaineering equipment — Harnesses — Safety requirements and test methods*

EN 12927-6, *Safety requirements for cableway installations designed to carry persons — Ropes — Part 6: Discard criteria*

EN 13411-1, *Terminations for steel wire ropes — Safety — Part 1: Thimbles for steel wire rope slings*

EN 13411-2, *Terminations for steel wire ropes — Safety — Part 2: Splicing of eyes for wire rope slings*

EN 13411-3:2004+A1:2008, *Terminations for steel wire ropes - Safety - Part 3: Ferrules and ferrule-securing*

EN 13411-4, *Terminations for steel wire ropes - Safety - Part 4: Metal and resin socketing*

EN 13411-5, *Terminations for steel wire ropes — Safety — Part 5: U-bolt wire rope grips*

EN 13411-6, *Terminations for steel wire ropes — Safety — Part 6: Asymmetric wedge socket*



EN 13411-7, *Terminations for steel wire ropes — Safety — Part 7: Symmetric wedge socket*

EN 15567-2:2015, *Sports- and recreational facilities - Ropes courses - Part 2: Operation requirements*

ISO 4309:2010, *Cranes — Wire ropes — Care and maintenance, inspection and discard*

### 3 Terms and definitions

For the purposes of this document, the following terms and definitions apply.

#### 3.1

##### ropes course

constructed facility consisting of one or more activity systems, support systems and, if needed, an appropriate safety system with restricted access and requiring supervision

Note 1 to entry: See Figure 1.

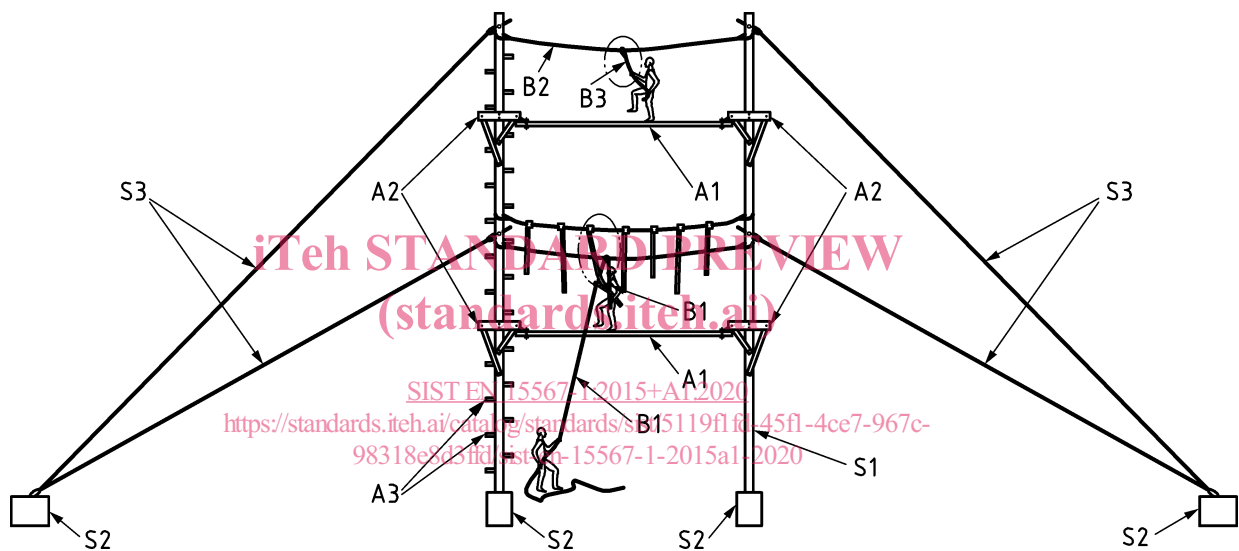

#### Key

Activity systems A		Support systems S		Belaying systems B	
A1	Elements	S1	Poles	B1	Assisted belaying system
A2	Platforms	S2	trees buildings, rock, other supporting structures	B2	Safety line
A3	Access	S3	Foundations, anchors Guy lines	B3	Safety system (categories A to E)

Figure 1 — Example of a ropes course

#### 3.2

##### permanent ropes course

facility installed for more than seven days on the same site

**EN 15567-1:2015+A1:2020 (E)****3.3****temporary ropes course**

facility that is not a mobile ropes course and is installed for a maximum of seven days

**3.4****mobile ropes course**

facility constructed in such a way that the support system is transportable from site to site

**3.5****support system**

artificial and/or natural structure intended for installation of activity and safety systems

Note 1 to entry: See Figure 1 for examples.

**3.6****activity system**

facility that permits the progression of the participant

EXAMPLE Examples are elements, platforms and access structures, see Figure 1.

**3.7****element**

activity unit in a ropes course

**iTeh STANDARD PREVIEW**  
**(standards.iteh.ai)**

**3.8****platform**

raised area usually before or after an element on which participants can stand

[SIST EN 15567-1:2015+A1:2020](https://standards.iteh.ai/catalog/standards/sist/5119f1fd-45f1-4ce7-967c-98318e8d3ffd/sist-en-15567-1-2015a1-2020)

**3.9****giant swing**

activity system where the participant performs guided pendulums (to- and-fro movements)

<https://standards.iteh.ai/catalog/standards/sist/5119f1fd-45f1-4ce7-967c-98318e8d3ffd/sist-en-15567-1-2015a1-2020>

**3.10****zip line**

activity system in which the participant glides under gravity in a sloping direction

**3.11****landing area**

area in which a participant exiting an element can land

**3.12****change-over**

manual transfer from one part of a safety system to another

**3.13****safety line**

flexible or rigid, horizontal, vertical or sloping, continuous or discontinuous device used as a protection against falling from a height

**3.14****interlocking device**

device with at least two gates whereby an action on the one gate results in an effect on another gate

EXAMPLE The opening of one gate causes the locking of another gate.

**3.15****safety system**

system used either to prevent, to arrest or cushion a participant's fall

Note 1 to entry: Examples of fall safety systems are guard rails, safety line, landing mat, net, retractable lifeline.

**3.16****individual safety system**

component(s) connecting the harness to the safety line

Note 1 to entry: Each of the following systems A to E provide adequate levels of safety when used in combination with appropriate supervision, training, instruction and information. See also EN 15567-2.

**3.16.1****individual safety system category A**

self-closing device which is not automatically self-locking

EXAMPLE Self-closing or screw gate connector.

**3.16.2****individual safety system category B**

self-locking device

EXAMPLE Self-locking connector.

**3.16.3****individual safety system category C**

interlocking device designed to reduce the likelihood of unintentional detaching from the safety system

**3.16.4****individual safety system category D**

interlocking device designed to prevent unintentional detaching from the safety system

**3.16.5****individual safety system category E**

device that is permanently attached during operation and can only be opened with a tool

**3.17****collective safety system**

system which can protect at least one person and, once properly installed or erected, does not require any action by the user to make sure it will work

Note 1 to entry: Examples include scaffolds, towers, nets, airbags, etc.

**3.18****assisted belay system**

belaying system where the participant is secured by at least one person

**3.19****spotting**

one or more persons working to catch, hold or give physical support to other participants

**3.20****critical application**

application where the consequences of a failure are likely to lead to a serious injury or death

ITEH STANDARD PREVIEW  
(standards.iteh.ai)

SIST EN 15567-1:2015+A1:2020

<https://standards.iteh.ai/catalog/standards/sist/5119f1fd-45f1-4ce7-967c-98318e8d3ffd/sist-en-15567-1-2015a1-2020>

## EN 15567-1:2015+A1:2020 (E)

**3.21****serious injury** <ropes courses>

any of the following injuries:

- fractures, other than to fingers, thumbs and toes;
- amputations;
- any injury likely to lead to permanent loss of sight or reduction in sight;
- any crush injury to the head or torso causing damage to the brain or internal organs;
- serious burns (including scalding) which:
  - covers more than 10 % of the body;
  - causes significant damage to the eyes, respiratory system or other vital organs;
- any scalping requiring hospital treatment;
- any loss of consciousness caused by head injury or asphyxia;
- any other injury arising from working in an enclosed space which:
  - leads to hypothermia or heat-induced illness;
  - requires resuscitation or admittance to hospital for more than 24 h

iTeh STANDARD PREVIEW  
(standards.iteh.ai)

**3.22****primary brake**

braking system engaged during normal operation to arrest the participant which can be either active or passive

[SIST EN 15567-1:2015+A1:2020](https://standards.iteh.ai/catalog/standards/sist/5119f1fd-45f1-4ce7-967c-98318e8d3ffd/sist-en-15567-1-2015a1-2020)

<https://standards.iteh.ai/catalog/standards/sist/5119f1fd-45f1-4ce7-967c-98318e8d3ffd/sist-en-15567-1-2015a1-2020>

**3.22.1****active braking system**

braking system operated by the participant or another person

**3.22.2****passive braking system**

braking system operating without manual intervention

**EXAMPLE**

Examples are bungee, gravity, net, water, impact absorbers, impact absorbent floors, landing mats, etc.

**3.23****emergency brake**

passive braking system that controls participant deceleration upon failure of the primary brake without causing serious injury or death

**3.24****level 1 supervision**

situation whereby an instructor can physically intervene to prevent a misuse of the individual safety system that would otherwise lead to a significant risk of serious injury or death

**3.25****level 2 supervision**

situation whereby an instructor is able to see the participant and intervene verbally

**3.26****level 3 supervision**

situation whereby a participant is in a position to alert an instructor of their need for assistance, who is able to respond promptly to the alert and provide adequate assistance

Note 1 to entry: It is intended that the role of the instructor is to be available to provide adequate assistance to a participant if called upon to do so. This is a largely reactive, rather than proactive, role.

**3.27****fall factor**

the height of the fall or distance fallen divided by the length of the lanyard or rope that is used

**3.28****falling space**

any space into which a participant may enter during a fall stopped by the safety system

**3.29****free space**

space in, on or around an element that can accommodate a participant whilst attached to the safety system

**EXAMPLE**

Examples are oscillating space for a zip line or for a giant swing.

**3.30****free height of fall**

greatest vertical distance from the clearly intended structure supporting the body to the impact area below

**3.31****dead load**

weight of the element when unloaded

**3.32****characteristic load**

maximum (un-factored) load that can be generated in normal use

**3.33****imposed load**

load corresponding to the average weight of a participant multiplied by the number of participants simultaneously authorized on the element

**3.34****dynamic load**

vertical impact force imposed on the safety system generated by a falling participant

**3.35****routine visual check**

inspection intended to identify obvious hazards that can result from vandalism, use or weather conditions