

---

---

**Protective clothing for users of hand-  
held chainsaws —**

**Part 3:  
Test methods for footwear**

*Vêtements de protection pour utilisateurs de scies à chaîne tenues à  
la main —*

**iTeh STANDARD PREVIEW**  
*Partie 3: Méthodes d'essai pour chaussures*  
**(standards.iteh.ai)**

[ISO 11393-3:2018](https://standards.iteh.ai/catalog/standards/sist/85193813-ae57-4eba-8417-2c372a2a7e94/iso-11393-3-2018)

[https://standards.iteh.ai/catalog/standards/sist/85193813-ae57-4eba-8417-  
2c372a2a7e94/iso-11393-3-2018](https://standards.iteh.ai/catalog/standards/sist/85193813-ae57-4eba-8417-2c372a2a7e94/iso-11393-3-2018)



**iTeh STANDARD PREVIEW**  
**(standards.iteh.ai)**

ISO 11393-3:2018

<https://standards.iteh.ai/catalog/standards/sist/85193813-ae57-4eba-8417-2c372a2a7e94/iso-11393-3-2018>



**COPYRIGHT PROTECTED DOCUMENT**

© ISO 2018

All rights reserved. Unless otherwise specified, or required in the context of its implementation, no part of this publication may be reproduced or utilized otherwise in any form or by any means, electronic or mechanical, including photocopying, or posting on the internet or an intranet, without prior written permission. Permission can be requested from either ISO at the address below or ISO's member body in the country of the requester.

ISO copyright office  
CP 401 • Ch. de Blandonnet 8  
CH-1214 Vernier, Geneva  
Phone: +41 22 749 01 11  
Fax: +41 22 749 09 47  
Email: [copyright@iso.org](mailto:copyright@iso.org)  
Website: [www.iso.org](http://www.iso.org)

Published in Switzerland

# Contents

	Page
Foreword.....	iv
Introduction.....	vi
<b>1 Scope.....</b>	<b>1</b>
<b>2 Normative references.....</b>	<b>1</b>
<b>3 Terms and definitions.....</b>	<b>1</b>
<b>4 Test specimens.....</b>	<b>1</b>
<b>5 Checking of protective area.....</b>	<b>2</b>
5.1 Sizing body for laced footwear.....	2
5.2 Procedure.....	2
<b>6 Testing resistance to cutting.....</b>	<b>3</b>
6.1 Apparatus.....	3
6.1.1 Test rig.....	3
6.1.2 Footwear mounting devices.....	3
6.1.3 Material for filling footwear.....	3
6.2 Test procedure.....	4
6.2.1 General.....	4
6.2.2 Cuts on vamp area.....	5
6.2.3 Cuts on throat area.....	6
6.2.4 Cuts on leg region.....	7
6.2.5 Additional cuts for footwear with non-steel toecaps.....	9
<b>7 Test report.....</b>	<b>9</b>

ISO 11393-3:2018

<https://standards.iteh.ai/catalog/standards/sist/85193813-ae57-4eba-8417-2c372a2a7e94/iso-11393-3-2018>

## Foreword

ISO (the International Organization for Standardization) is a worldwide federation of national standards bodies (ISO member bodies). The work of preparing International Standards is normally carried out through ISO technical committees. Each member body interested in a subject for which a technical committee has been established has the right to be represented on that committee. International organizations, governmental and non-governmental, in liaison with ISO, also take part in the work. ISO collaborates closely with the International Electrotechnical Commission (IEC) on all matters of electrotechnical standardization.

The procedures used to develop this document and those intended for its further maintenance are described in the ISO/IEC Directives, Part 1. In particular the different approval criteria needed for the different types of ISO documents should be noted. This document was drafted in accordance with the editorial rules of the ISO/IEC Directives, Part 2 (see [www.iso.org/directives](http://www.iso.org/directives)).

Attention is drawn to the possibility that some of the elements of this document may be the subject of patent rights. ISO shall not be held responsible for identifying any or all such patent rights. Details of any patent rights identified during the development of the document will be in the Introduction and/or on the ISO list of patent declarations received (see [www.iso.org/patents](http://www.iso.org/patents)).

Any trade name used in this document is information given for the convenience of users and does not constitute an endorsement.

For an explanation on the voluntary nature of standards, the meaning of ISO specific terms and expressions related to conformity assessment, as well as information about ISO's adherence to the World Trade Organization (WTO) principles in the Technical Barriers to Trade (TBT) see the following URL: [www.iso.org/iso/foreword.html](http://www.iso.org/iso/foreword.html). (standards.iteh.ai)

This document was prepared by the European Committee for Standardization (CEN) Technical Committee CEN/TC 162, *Protective clothing including hand and arm protection and lifejackets*, in collaboration with ISO Technical Committee TC 94, *Personal safety* – *Personal protective equipment*, Subcommittee SC 13, *Protective clothing*, in accordance with the agreement on technical cooperation between ISO and CEN (Vienna Agreement).

This second edition cancels and replaces the first edition (ISO 11393-3:1999), which has been technically revised. The main changes compared to the previous edition are as follows:

- in the Introduction, the term “hand-held chainsaws primarily constructed for cutting wood” has been added;
- the normative references have been updated;
- the term and definition 3.1 has been added;
- in Clause 4, the definition has been adapted to 6.2;
- in Clause 5, the definition and normative reference has been specified;
- in 6.1.2.2, 6.2.1, 6.2.2, 6.2.3, 6.2.4 and Clause 7, definitions have been specified;
- in 6.1.3, a new comprising procedure has been defined;
- in 6.2.1, the total number of cuts has been enlarged, “protection class” has been renamed as “level” and “class 0” has been deleted;
- in 6.2.4, an alternative system for fastening the footwear to the test rig has been added;
- in 6.2.5, the definition “non-steel” has been used following ISO 17249.

A list of all parts in the ISO 11393 series can be found on the ISO website.

Any feedback or questions on this document should be directed to the user's national standards body. A complete listing of these bodies can be found at [www.iso.org/members.html](http://www.iso.org/members.html).

**iTeh STANDARD PREVIEW**  
**(standards.iteh.ai)**

ISO 11393-3:2018

<https://standards.iteh.ai/catalog/standards/sist/85193813-ae57-4eba-8417-2c372a2a7e94/iso-11393-3-2018>

## Introduction

This document forms part of a series concerned with personal protective equipment (PPE) designed to protect against the risks arising from the use of hand-held chainsaws primarily constructed for cutting wood.

No PPE can ensure a 100 % protection against cutting from a hand-held chainsaw. Nevertheless, experience has shown that it is possible to design PPE that offers a certain degree of protection.

Different functional principles may be applied in order to give protection. These include:

- a) chain slipping: on contact the chain does not cut the material;
- b) clogging: fibres are drawn by the chain into the drive sprocket and block chain movement;
- c) chain braking: fibres have a high resistance to cutting and absorb rotational energy, thereby reducing the chain speed.

Often more than one principle is applied.

## iTeh STANDARD PREVIEW (standards.iteh.ai)

[ISO 11393-3:2018](https://standards.iteh.ai/catalog/standards/sist/85193813-ae57-4eba-8417-2c372a2a7e94/iso-11393-3-2018)

<https://standards.iteh.ai/catalog/standards/sist/85193813-ae57-4eba-8417-2c372a2a7e94/iso-11393-3-2018>

# Protective clothing for users of hand-held chainsaws —

## Part 3: Test methods for footwear

### 1 Scope

This document specifies test methods for assessing the resistance of footwear to cutting by hand-held chainsaws.

This document is applicable only to footwear with integral protection.

NOTE Methods for testing other forms of foot and leg protection (e.g. gaiters) against hand-held chainsaws are covered in other parts of the ISO 11393 series.

### 2 Normative references

The following documents are referred to in the text in such a way that some or all of their content constitutes requirements of this document. For dated references, only the edition cited applies. For undated references, the latest edition of the referenced document (including any amendments) applies.

ISO 11393-1:2018, *Protective clothing for users of hand-held chainsaws — Part 1: Test rig for testing resistance to cutting by a chainsaw*

ISO 17249, *Safety footwear with resistance to chain saw cutting*

ISO 20344:2011, *Personal protective equipment — Test methods for footwear*

### 3 Terms and definitions

For the purposes of this document, the following terms and definitions apply.

ISO and IEC maintain terminological databases for use in standardization at the following addresses:

- ISO Online browsing platform: available at <https://www.iso.org/obp>
- IEC Electropedia: available at <http://www.electropedia.org/>

#### 3.1

##### **cut-through**

any visible change on the underside of the innermost layer of the test sample caused by the saw chain

#### 3.2

##### **integral protection**

footwear in which the chainsaw protective material either comprises the material of the footwear or is permanently attached to the footwear

### 4 Test specimens

For footwear with steel toecaps, four pairs of three different sizes, representing the smallest, largest and medium size, shall be tested.

For footwear with non-steel toecaps, five pairs of three different sizes, representing the smallest, largest and medium size, shall be tested.

Additional samples can be needed for additional test cuts according to 6.2.1.

## 5 Checking of protective area

### 5.1 Sizing body for laced footwear

The sizing body for laced footwear shall have a total height of minimum 500 mm, comprising:

- ankle cylinder: height  $(76 \pm 1)$  mm; diameter  $(84 \pm 1)$  mm;
- conical section: height  $(274 \pm 1)$  mm;
- upper cylinder: height 150 mm min.; diameter  $(110 \pm 1)$  mm.

See Figure 1.

Dimensions in millimetres

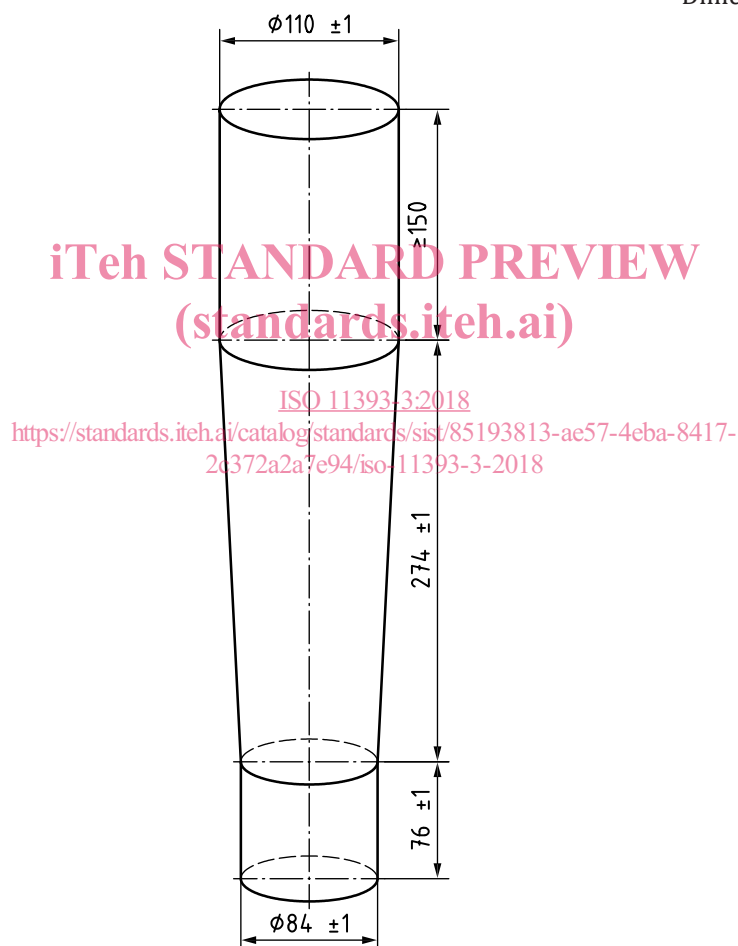

Figure 1 — Sizing body for laced footwear

### 5.2 Procedure

Insert the sizing body for laced footwear into the leg of the footwear and tighten any fastenings (e.g. laces or straps) about it. Measure the protective area given in ISO 17249.

Test one pair each of the smallest, largest and medium sizes. Samples that have been cut tested according to 6.2 may be used.



Check and report whether the protective material extends throughout the protective area as specified by ISO 17249.

Report any gaps or areas not covered by protective material.

Report whether the protective material is continuous throughout the protective area specified, and whether the protective material consists of more than one type of material.

## 6 Testing resistance to cutting

### 6.1 Apparatus

#### 6.1.1 Test rig

The test rig shall be as described in ISO 11393-1, with additional elements to fulfil the requirements of 6.2.

#### 6.1.2 Footwear mounting devices

##### 6.1.2.1 Base

The base for mounting the footwear shall be capable of holding the footwear in the required positions.

Devices for fixing the footwear to the base, including holes and bolts, shall not interfere with the protective material under test.

##### 6.1.2.2 Test mount

The test mount shall be made of hardwood or similar material, covered with a  $(14 \pm 2)$  mm thick layer of flexible cellular material of copolymer foam as described in ISO 11393-1:2018, 5.4.

The diameter of the cylinder shall be  $(50 \pm 1)$  mm plus the thickness of the cellular material.

See [Figure 2](#).

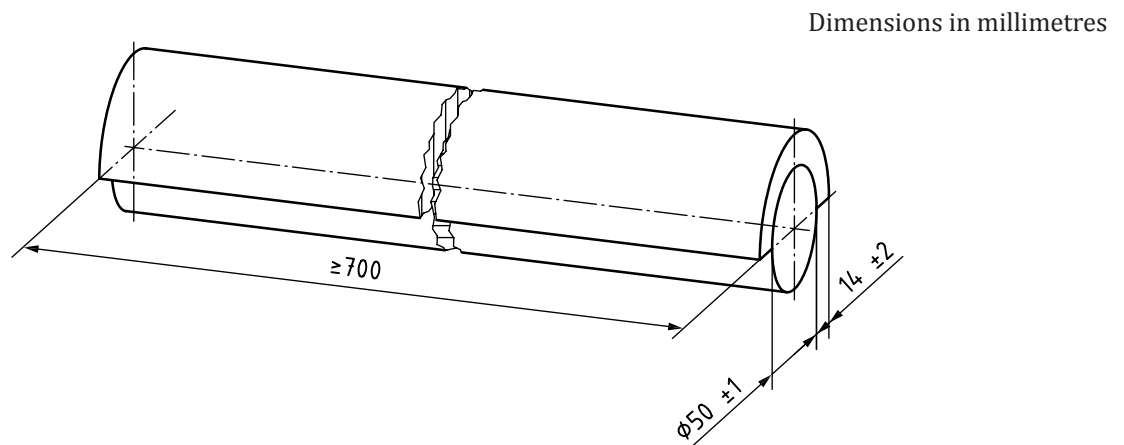

Figure 2 — Test mount

#### 6.1.3 Material for filling footwear

The material for filling footwear comprises:

- dry peas;