

# INTERNATIONAL STANDARD

Information technology – Underwater Acoustic Sensor Network (UWASN) –  
Part 4: Interoperability

**(standards.iteh.ai)**

[ISO/IEC 30140-4:2018](#)

<https://standards.iteh.ai/catalog/standards/sist/8b6c8984-ecf5-4a93-8829-c2dc394f52e2/iso-iec-30140-4-2018>



**THIS PUBLICATION IS COPYRIGHT PROTECTED**  
**Copyright © 2018 ISO/IEC, Geneva, Switzerland**

All rights reserved. Unless otherwise specified, no part of this publication may be reproduced or utilized in any form or by any means, electronic or mechanical, including photocopying and microfilm, without permission in writing from either IEC or IEC's member National Committee in the country of the requester. If you have any questions about ISO/IEC copyright or have an enquiry about obtaining additional rights to this publication, please contact the address below or your local IEC member National Committee for further information.

IEC Central Office  
3, rue de Varembe  
CH-1211 Geneva 20  
Switzerland

Tel.: +41 22 919 02 11  
[info@iec.ch](mailto:info@iec.ch)  
[www.iec.ch](http://www.iec.ch)

**About the IEC**

The International Electrotechnical Commission (IEC) is the leading global organization that prepares and publishes International Standards for all electrical, electronic and related technologies.

**About IEC publications**

The technical content of IEC publications is kept under constant review by the IEC. Please make sure that you have the latest edition, a corrigenda or an amendment might have been published.

**IEC Catalogue - [webstore.iec.ch/catalogue](http://webstore.iec.ch/catalogue)**

The stand-alone application for consulting the entire bibliographical information on IEC International Standards, Technical Specifications, Technical Reports and other documents. Available for PC, Mac OS, Android Tablets and iPad.

**IEC publications search - [webstore.iec.ch/advsearchform](http://webstore.iec.ch/advsearchform)**

The advanced search enables to find IEC publications by a variety of criteria (reference number, text, technical committee,...). It also gives information on projects, replaced and withdrawn publications.

**IEC Just Published - [webstore.iec.ch/justpublished](http://webstore.iec.ch/justpublished)**

Stay up to date on all new IEC publications. Just Published details all new publications released. Available online and also once a month by email.

**Electropedia - [www.electropedia.org](http://www.electropedia.org)**

The world's leading online dictionary of electronic and electrical terms containing 21 000 terms and definitions in English and French, with equivalent terms in 16 additional languages. Also known as the International Electrotechnical Vocabulary (IEV) online.

**IEC Glossary - [std.iec.ch/glossary](http://std.iec.ch/glossary)**

67 000 electrotechnical terminology entries in English and French extracted from the Terms and Definitions clause of IEC publications issued since 2002. Some entries have been collected from earlier publications of IEC TC 37, 77, 86 and CISPR.

**IEC Customer Service Centre - [webstore.iec.ch/csc](http://webstore.iec.ch/csc)**

If you wish to give us your feedback on this publication or need further assistance, please contact the Customer Service Centre: [sales@iec.ch](mailto:sales@iec.ch)

<https://standards.iteh.ai/catalog/standards/sist/866914-ccc5-4a93-8829-c2dc394f52e2/iso-iec-30140-4-2018>



ISO/IEC 30140-4

Edition 1.0 2018-07

# INTERNATIONAL STANDARD

---

Information technology – Underwater Acoustic Sensor Network (UWASN) –  
Part 4: Interoperability  
**(standards.iteh.ai)**

ISO/IEC 30140-4:2018  
<https://standards.iteh.ai/catalog/standards/sist/8b6c8984-ecf5-4a93-8829-c2dc394f52e2/iso-iec-30140-4-2018>

INTERNATIONAL  
ELECTROTECHNICAL  
COMMISSION

---

ICS 35.110

ISBN 978-2-8322-5913-9

**Warning! Make sure that you obtained this publication from an authorized distributor.**

## CONTENTS

FOREWORD.....	3
INTRODUCTION.....	4
1 Scope.....	5
2 Normative references .....	5
3 Terms and definitions .....	5
4 Abbreviated terms .....	5
5 Interoperability in UWASN .....	6
5.1 Overview.....	6
5.1.1 Interoperability definition .....	6
5.1.2 Achieving interoperability.....	6
5.1.3 The need for interoperability .....	6
5.1.4 UWASN interoperability .....	6
5.2 Interoperability between the user and the UWA-GW.....	9
5.3 Interoperability between the UWA-GW and the UWA-FN.....	9
5.4 Interoperability between UWA-FNs .....	10
5.5 Interoperability between UWA-GWs .....	11
6 UWASN communication technology interoperability architecture point of view .....	11
7 UWASN communication technology interoperability architecture from service point of view.....	12
7.1 General.....	12
7.2 Example: Interoperability between heterogeneous networks .....	14
Bibliography.....	16
Figure 1 – Interoperability in UWASN.....	8
Figure 2 – Graphical representation of interoperable UWASN .....	8
Figure 3 – Interoperability of UWASN .....	9
Figure 4 – Generic standardized interface for interoperability in UWASNs .....	9
Figure 5 – Multiple interfaces on a UWA-GW to provide interoperability in UWASN.....	10
Figure 6 – Interoperability between fundamental networks .....	11
Figure 7 – Interoperability between UWA-GWs .....	11
Figure 8 – UWASN communication technology interoperability architecture point of view.....	12
Figure 9 – UWASN communication technology interoperability architecture a from service point of view .....	13
Figure 10 – Interoperability between heterogeneous networks .....	15
Table 1 – UWASN CTI-AP Entities .....	14
Table 2 – UWASN CTI-AP interoperability .....	14

ITCI STANDARD PREVIEW  
 (standards.iteh.ai)  
 ISO/IEC 30140-4:2018  
<https://standards.iteh.ai/catalog/standards/sist/8b6c8984-ecf5-4a93-8829-c2dc394f52e2/iso-iec-30140-4-2018>

# INFORMATION TECHNOLOGY – UNDERWATER ACOUSTIC SENSOR NETWORK (UWASN) –

## Part 4: Interoperability

### FOREWORD

- 1) ISO (the International Organization for Standardization) and IEC (the International Electrotechnical Commission) form the specialized system for worldwide standardization. National bodies that are members of ISO or IEC participate in the development of International Standards through technical committees established by the respective organization to deal with particular fields of technical activity. ISO and IEC technical committees collaborate in fields of mutual interest. Other international organizations, governmental and non-governmental, in liaison with ISO and IEC, also take part in the work. In the field of information technology, ISO and IEC have established a joint technical committee, ISO/IEC JTC 1.
- 2) The formal decisions or agreements of IEC and ISO on technical matters express, as nearly as possible, an international consensus of opinion on the relevant subjects since each technical committee has representation from all interested IEC National Committees and ISO member bodies.
- 3) IEC, ISO and ISO/IEC publications have the form of recommendations for international use and are accepted by IEC National Committees and ISO member bodies in that sense. While all reasonable efforts are made to ensure that the technical content of IEC, ISO and ISO/IEC publications is accurate, IEC or ISO cannot be held responsible for the way in which they are used or for any misinterpretation by any end user.
- 4) In order to promote international uniformity, IEC National Committees and ISO member bodies undertake to apply IEC, ISO and ISO/IEC publications transparently to the maximum extent possible in their national and regional publications. Any divergence between any ISO, IEC or ISO/IEC publication and the corresponding national or regional publication should be clearly indicated in the latter.
- 5) ISO and IEC do not provide any attestation of conformity. Independent certification bodies provide conformity assessment services and, in some areas, access to IEC marks of conformity. ISO or IEC are not responsible for any services carried out by independent certification bodies.
- 6) All users should ensure that they have the latest edition of this publication.  
<https://standards.iteh.ai/catalog/standards/sist/8b6c8984-ecf5-4a93-8829-c2dc394b2e2/iso-iec-30140-4-2018>
- 7) No liability shall attach to IEC or ISO or its directors, employees, servants or agents including individual experts and members of their technical committees and IEC National Committees or ISO member bodies for any personal injury, property damage or other damage of any nature whatsoever, whether direct or indirect, or for costs (including legal fees) and expenses arising out of the publication of, use of, or reliance upon, this ISO/IEC publication or any other IEC, ISO or ISO/IEC publications.
- 8) Attention is drawn to the normative references cited in this publication. Use of the referenced publications is indispensable for the correct application of this publication.
- 9) Attention is drawn to the possibility that some of the elements of this ISO/IEC publication may be the subject of patent rights. ISO and IEC shall not be held responsible for identifying any or all such patent rights.

International Standard ISO/IEC 30140-4 was prepared by subcommittee 41: Internet of Things and related technologies, of ISO/IEC joint technical committee 1: Information technology.

The list of all currently available parts of the ISO/IEC 30140 series, under the general title *Information technology – Underwater acoustic sensor network (UWASN)*, can be found on the IEC and ISO websites.

This International Standard has been approved by vote of the member bodies, and the voting results may be obtained from the address given on the second title page.

This publication has been drafted in accordance with the ISO/IEC Directives, Part 2.

A bilingual version of this publication may be issued at a later date.

## INTRODUCTION

Water covers approximately 71 % of the surface of the Earth. Modern technologies introduce new methods to monitor the body of water, for example pollution monitoring and detection. Underwater data gathering techniques require exploring the water environment, which can be most effectively performed by underwater acoustic sensor networks (UWASNs). Applications developed for the UWASNs can record underwater climate, detect and control water pollution, monitor marine biology, discover natural resources, detect pipeline leakages, monitor and locate underwater intruders, perform strategic surveillance, and so on.

The ISO/IEC 30140 series provides general requirements, reference architecture (RA) including the entity models and high-level interface guidelines supporting interoperability among UWASNs in order to provide the essential UWASN construction information to help and guide architects, developers and implementers of UWASNs.

Additionally, the ISO/IEC 30140 series provides high-level functional models related to underwater sensor nodes and relationships among the nodes to construct architectural perspective of UWASNs. However, the ISO/IEC 30140 series is an application agnostic standard. Thus, the ISO/IEC 30140 series specifies neither any type of communication waveforms for use in UWASNs nor any underwater acoustic communication frequencies. Specifying communication waveforms and/or frequencies are the responsibility of architects, developers and implementers<sup>1</sup>.

Acoustical data communication in sensor networks necessitates the introduction of acoustical signals that overlap biologically important frequency bands into the subject environment. These signals can conflict with regional, national, or international noise exposure regulations. Implementers of acoustical communication networks should consult the relevant regulatory agencies prior to designing and deployment of these systems to ensure compliance with regulations and avoid conflicts with the agencies.

<https://standards.iteh.ai/catalog/standards/sist/8b6c8984-ecf5-4a93-8829-140331e321e0/iso-iec-30140-4-2018>

The purpose of the ISO/IEC 30140 series is to provide general requirements, guidance and facilitation in order for the users of the ISO/IEC 30140 series to design and develop the target UWASNs for their applications and services.

The ISO/IEC 30140 series comprises four parts as shown below.

- Part 1 provides a general overview and requirements of the UWASN reference architecture.
- Part 2 provides reference architecture models for UWASN.
- Part 3 provides descriptions for the entities and interfaces of the UWASN reference architecture.
- Part 4 provides information on interoperability requirements among the entities within a UWASN and among various UWASNs.

---

<sup>1</sup> Architects, developers, and implementers need to be aware of the submarine emergency frequency band, near and below 12 kHz, and it is recommended to provide a provision for such submarine emergency band in their UWASN design and applications.

# INFORMATION TECHNOLOGY – UNDERWATER ACOUSTIC SENSOR NETWORK (UWASN) –

## Part 4: Interoperability

### 1 Scope

This part of ISO/IEC 30140 specifies interoperability between the selected physical entities of UWASN.

### 2 Normative references

The following documents are referred to in the text in such a way that some or all of their content constitutes requirements of this document. For dated references, only the edition cited applies. For undated references, the latest edition of the referenced document (including any amendments) applies.

ISO/IEC 29182-2, *Information technology – Sensor networks: Sensor Network Reference Architecture (SNRA) – Part 2: Vocabulary and terminology*

iTeh STANDARD PREVIEW

### 3 Terms and definitions (standards.iteh.ai)

For the purposes of this document, the terms and definitions given in ISO/IEC 29182-2 apply.

ISO and IEC maintain terminological databases for use in standardization at the following addresses:

- IEC Electropedia: available at <http://www.electropedia.org/>
- ISO Online browsing platform: available at <http://www.iso.org/obp>

### 4 Abbreviated terms

ad-hoc UWA-SNode	ad-hoc underwater acoustic sensor node
CTI-AP	communication technology interoperability architecture point of view
CTI-SP	communication technology interoperability architecture from service point of view
UWA-APS	underwater application layer
UWA-BUN	underwater bundle layer
UWA-DL	underwater datalink layer
UWA-EUN	underwater acoustic extend united network
UWA-FN	underwater acoustic fundamental network
UWA-GW	underwater acoustic gateway
UWA-NWK	underwater network layer
UWA-PHY	underwater physical layer
UWA-SNode	underwater acoustic sensor node
UWASN	underwater acoustic sensor network
UWA-UN	underwater acoustic united network

## 5 Interoperability in UWASN

### 5.1 Overview

#### 5.1.1 Interoperability definition

Interoperability refers to the ability of two or more components, applications, devices, systems, or networks to exchange information.

#### 5.1.2 Achieving interoperability

Interoperability can be achieved using a gateway between networks for protocol translation, by having standard interfaces, or by defining common protocols between networks.

#### 5.1.3 The need for interoperability

End-to-end connectivity is required to achieve interoperability. To maintain end-to-end communication, heterogeneous networks can interoperate with the help of a gateway.

UWASN interoperability allows underwater data to be transferred between heterogeneous networks effectively.

UWASN interoperability is typically related to the following.

- Software or hardware platforms, components, and systems enable device-to-device communication. Typically, these types of interoperability focus on communication protocols and infrastructure. (standards.iteh.ai)
- Data formats should have well-defined syntax and encoding to transfer messages using communication protocols. ISO/IEC 30140-4:2018
- For interoperability at the content level, the meaning of exchanged information has to be understood by both elements. <https://standards.iteh.ai/catalog/standards/sist/8b6c8984-ecf5-4a93-8829-c2dc394f52e2/iso-iec-30140-4-2018>

Interoperability can be achieved by a standard development process that promotes open architectures and standardization of interfaces between UWASN service frameworks.

The ability to read and process information and exchange data between heterogeneous networks is mandatory for interoperability, as shown in Figure 1. Defining standardized interfaces for the UWASN is the most efficient way to make sensor networks interoperable.

Standardized interfaces should include the following:

- 1) standardized data format, type, name, definition and data processing rules;
- 2) standardized communication interfaces between UWASN service framework entities.

#### 5.1.4 UWASN interoperability

UWASN is a system of spatially distributed underwater acoustic sensor nodes that interact acquire, process, and provide information about the underwater environment and optionally react to such information.

There are numerous different UWASN applications such as environmental monitoring, assisted navigation, disaster prevention, and tactical surveillance. Depending on the domain, significant differences exist in the service requirements, service types, processing functions, interfaces, operational attributes, and data formats. These differences influence the interoperability of UWASNs.

Due to these differences, a UWASN can be classified as either homogeneous or heterogeneous.



The differentiation of homogeneous and heterogeneous UWASNs can be viewed from underwater sensor type and communication protocol perspective. From the sensor type perspective, homogeneous sensor networks can be classified as having the same type or functionally identical UWA-SNodes. Heterogeneous UWASNs can be classified as having different types of UWA-SNodes or functionally different UWA-SNodes. From the communication protocol perspective, homogeneous UWASNs can be classified as having the same or interoperable protocols, whereas heterogeneous UWASNs can be classified as having different or not interoperable protocols. In this document, the communication protocol perspective is used to differentiate the types of UWASNs.

From the communication protocol perspective, homogeneous UWASNs are interoperable because they use the same communication protocol between the entities of their service domains. On the other hand, heterogeneous UWASNs cannot interoperate because they use different communication protocols.

Heterogeneity is a common feature of UWASN; however, this can cause various problems. UWASN applications can rely on different sub-networks in a heterogeneous UWASN.

Therefore, interoperability between heterogeneous UWASNs is a significant challenge in the UWASN reference architecture.

The flow of information from UWA-FN to users can be represented in a hierarchical architecture (Figure 1).

- 1) Interoperability 1: between the user and gateway (mandatory)
- 2) Interoperability 2: between gateway and underwater fundamental network (mandatory)
- 3) Interoperability 3: between underwater fundamental networks (optional)
- 4) Interoperability 4: between gateways (optional)

<https://standards.iteh.ai/catalog/standards/sist/8b6c8984-ecf5-4a93-8829-c2dc394f52e2/iso-iec-30140-4-2018>

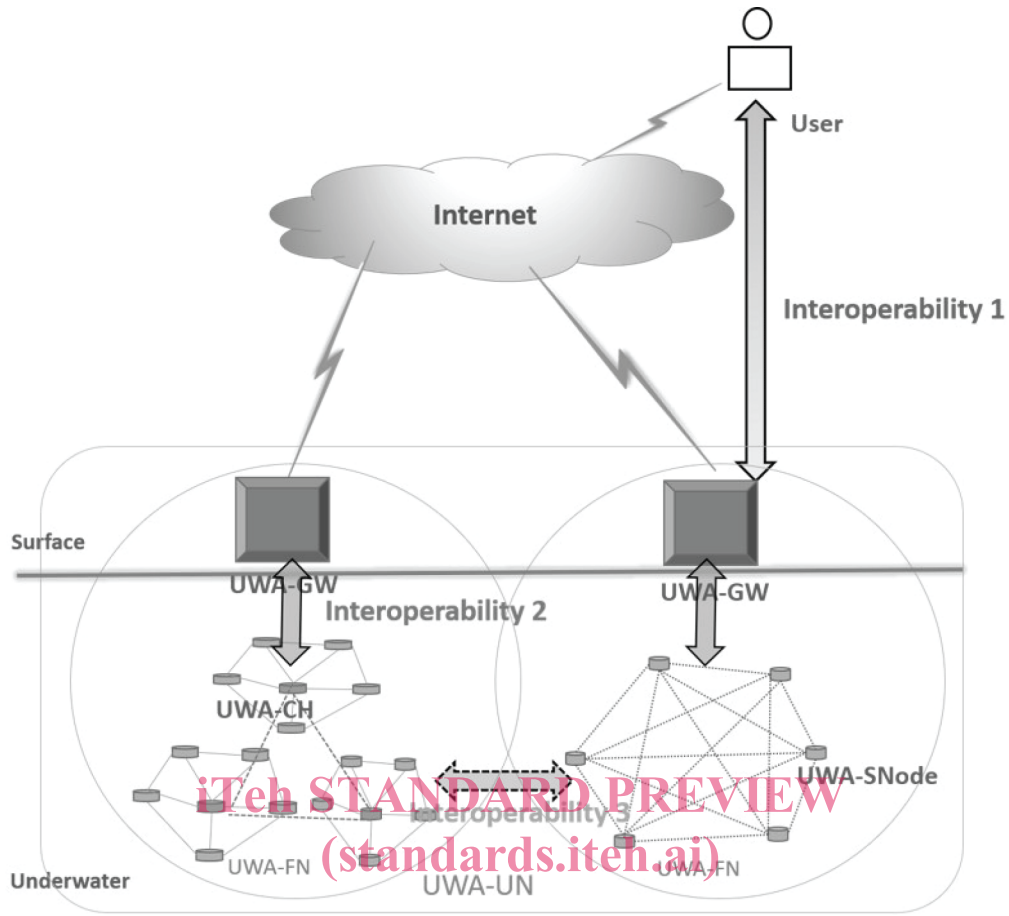

ISO/IEC 30140-4:2018

IEC

<https://standards.iteh.ai/catalog/standards/sist/8b6c8984-ecf5-4a93-8829-c2d6594b2c7d/iso-30140-4-2018>

**Figure 1 – Interoperability in UWASN**

There are various communication protocols or interfaces for each entity. Interoperability implies an internetworking capability between entities in the UWASN framework. Figure 2 is a graphical representation of an interoperable UWASN framework. Here, the arrows represent interfaces that enable seamless interoperability between entities.

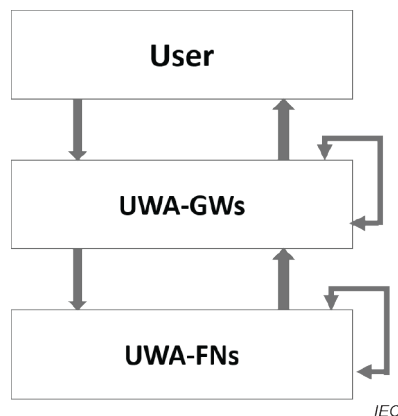

IEC

**Figure 2 – Graphical representation of interoperable UWASN**

Interoperability should also allow information to be exchanged seamlessly within the hierarchical structure of the sensor networks to support a complex system of systems. Therefore, various cases for the interoperability of sensor networks should be considered. Figure 3 illustrates the complexity of interoperability within this system of systems.

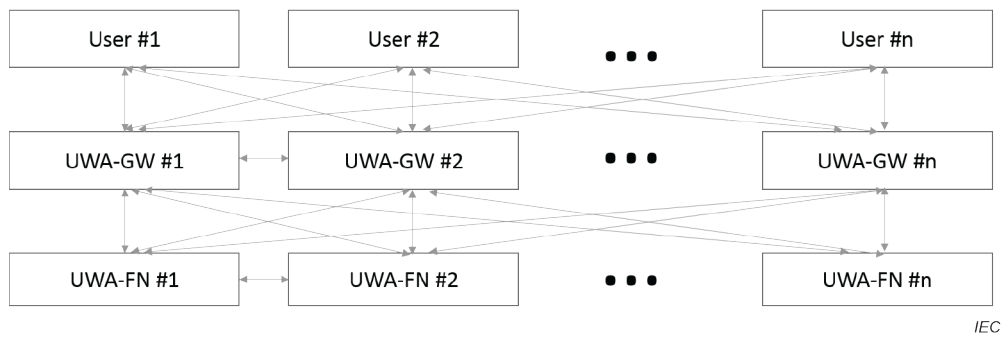

**Figure 3 – Interoperability of UWASN**

Various entities of the UWASN framework can use different communication technologies, protocols, and data formats. Therefore, data flow between various entities should be interoperable.

**5.2 Interoperability between the user and the UWA-GW**

UWA-GW is an intermediate entity that interconnects appropriate users and UWA-FNs. The data collected from the UWA-FNs and management messages, such as underwater data and device management messages, are exchanged via this interface.

iTech STANDARD PREVIEW  
(standards.iteh.ai)

The gateway should be capable of exchanging information with any user. Using a generic sensor network application interface is one way to ensure interoperability between the gateway and the user, as shown in Figure 4.

ISO/IEC 30140-4:2018

There are numerous approaches to ensure interoperability between the user and the gateway using the generic interface defined in ISO/IEC 29182-5.

A standardized interface specification and data format between the gateway and the user, shown as interoperability 1 in Figure 1, is defined in ISO/IEC 30140-3.

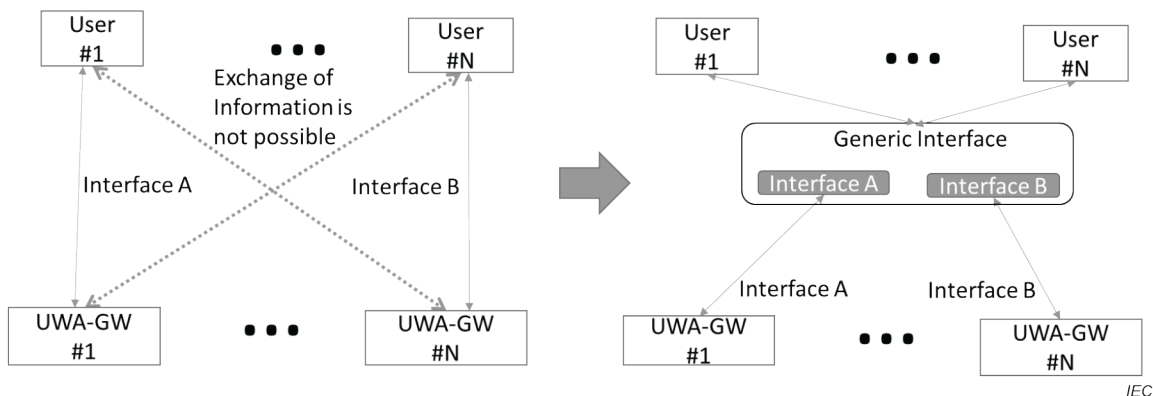

**Figure 4 – Generic standardized interface for interoperability in UWASNs**

**5.3 Interoperability between the UWA-GW and the UWA-FN**

The interface between UWA-FNs and UWA-GWs facilitates the transfer of data. UWA-GWs should be capable of extracting certain information from fundamental networks. UWA-GWs