



SLOVENSKI STANDARD
oSIST prEN 17928-3:2023
01-maj-2023

Infrastruktura za plin - Postaje za injiciranje - 3. del: Posebne zahteve za plinasti vodik

Gas infrastructure - Injection stations - Part 3: Specific requirements regarding the injection of hydrogen fuel gas

Gasinfrastruktur - Einspeiseanlagen - Part 3: Spezifische Anforderungen für die Einspeisung von Wasserstoff

Installation pour l'injection de gaz renouvelable dans les reseaux de gaz naturel - Partie 3: Exigences spécifiques pour hydrogen

Ta slovenski standard je istoveten z: prEN 17928-3

ICS:

27.190

Biološki viri in drugi
alternativni viri energije

Biological sources and
alternative sources of energy

oSIST prEN 17928-3:2023

en,fr,de

EUROPEAN STANDARD
NORME EUROPÉENNE
EUROPÄISCHE NORM

DRAFT
prEN 17928-3

April 2023

ICS 27.190

English Version

Gas infrastructure - Injection stations - Part 3: Specific requirements regarding the injection of hydrogen fuel gas

Installation pour l'injection de gaz renouvelable dans les réseaux de gaz naturel - Partie 1: Exigences spécifiques pour hydrogen

Gasinfrastruktur - Einspeiseanlagen - Part 3: Spezifische Anforderungen für die Einspeisung von Wasserstoff

This draft European Standard is submitted to CEN members for enquiry. It has been drawn up by the Technical Committee CEN/TC 234.

If this draft becomes a European Standard, CEN members are bound to comply with the CEN/CENELEC Internal Regulations which stipulate the conditions for giving this European Standard the status of a national standard without any alteration.

This draft European Standard was established by CEN in three official versions (English, French, German). A version in any other language made by translation under the responsibility of a CEN member into its own language and notified to the CEN-CENELEC Management Centre has the same status as the official versions.

CEN members are the national standards bodies of Austria, Belgium, Bulgaria, Croatia, Cyprus, Czech Republic, Denmark, Estonia, Finland, France, Germany, Greece, Hungary, Iceland, Ireland, Italy, Latvia, Lithuania, Luxembourg, Malta, Netherlands, Norway, Poland, Portugal, Republic of North Macedonia, Romania, Serbia, Slovakia, Slovenia, Spain, Sweden, Switzerland, Türkiye and United Kingdom.

Recipients of this draft are invited to submit, with their comments, notification of any relevant patent rights of which they are aware and to provide supporting documentation.

Warning : This document is not a European Standard. It is distributed for review and comments. It is subject to change without notice and shall not be referred to as a European Standard.



EUROPEAN COMMITTEE FOR STANDARDIZATION
COMITÉ EUROPÉEN DE NORMALISATION
EUROPÄISCHES KOMITEE FÜR NORMUNG

CEN-CENELEC Management Centre: Rue de la Science 23, B-1040 Brussels

Contents	Page
European foreword.....	3
1 Scope	4
2 Normative references	5
3 Terms, symbols, units, and abbreviations	5
4 General requirements	5
4.1 Specific requirements for hydrogen injection stations.....	5
4.2 Coordination and definition of interfaces.....	6
4.3 Requirements on the properties of hydrogen fuel gas.....	6
4.3.1 General.....	6
4.3.2 Injection for hydrogen fuel gas in methane-based grids	6
4.3.3 Requirements for injection into dedicated hydrogen grids	6
4.4 Explosion protection.....	6
5 Operational functions	7
5.1 General.....	7
5.2 Mixing hydrogen fuel gas with other gases.....	7
5.2.1 Homogeneity of the gas flow	7
5.2.2 Control of the hydrogen content.....	7
6 Overall safety requirements and protection against inadmissible operating modes	8
7 Specific requirements for systems and components	8
7.1 Key parameters for material selection	8
7.1.1 General.....	8
7.1.2 Hydrogen embrittlement (metallic materials)	8
7.1.3 Hydrogen permeation	8
7.1.4 Requirements on hydrogen injection stations.....	8
7.2 Systems	8
7.2.1 Monitoring of ambient atmosphere	8
7.2.2 Metrological requirements.....	8
7.3 Components	8
7.3.1 Requirements on buried pipelines.....	8
8 Testing and commissioning	9
8.1 General.....	9
8.2 Tightness tests.....	9
9 Operation	9
Bibliography	10

European foreword

This document (prEN 17928-3:2023) has been prepared by Technical Committee CEN/TC 234 “Gas infrastructure”, the secretariat of which is held by DIN.

This document is currently submitted to the CEN Enquiry.

This document is intended to be used in conjunction with prEN 17928-1.

This document is part of the EN 17928 series, *Gas infrastructure - Injection stations*:

- *Part 1: General requirements*
- *Part 2: Specific requirements regarding the injection of biomethane*
- *Part 3: Specific requirements regarding the injection of hydrogen fuel gas* (this document)

iTeh STANDARD PREVIEW
(standards.iteh.ai)

[oSIST prEN 17928-3:2023](https://standards.iteh.ai/catalog/standards/sist/6fd8f40e-9f45-4779-a63a-07013091ac36/osist-pren-17928-3-2023)

<https://standards.iteh.ai/catalog/standards/sist/6fd8f40e-9f45-4779-a63a-07013091ac36/osist-pren-17928-3-2023>

1 Scope

This document establishes specific functional requirements of stations for the injection of hydrogen fuel gas into transmission and distribution systems for fuel gases (natural gas, biomethane, SNG, hydrogen fuel gas, fuel gas mixtures, etc.; see Figure 1) in accordance with European technical rules that ensure the interoperability of systems in addition to the general functional requirements of prEN 17928-1.

This document complements prEN 17928-1 by specifying the technical safety requirements to be observed with respect to the chemical and physical properties of hydrogen fuel gas.

It furthermore complements the requirements on pipelines specified in EN 12007-3 and EN 1594 by describing the specific requirements with respect to hydrogen.

Additionally, it explains how to handle hydrogen measurements during the course of injection.

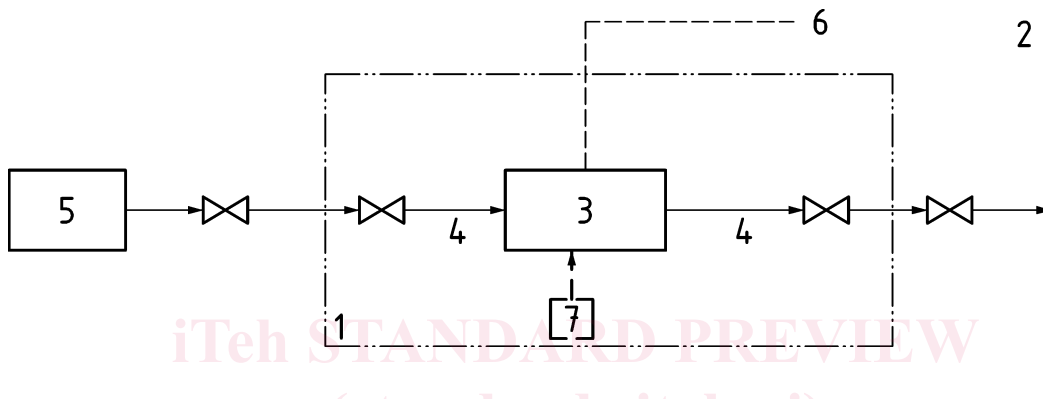

Key

- 1 injection station – scope of this document
- 2 gas transmission and distribution system
- 3 measuring and control station – pressure control/ compression / flow control / metering/gas-mixing (optional)
- 4 hydrogen pipeline (optional mixed-gas pipeline)
- 5 hydrogen fuel gas production
- 6 gas composition / flow information
- 7 gas-feed for mixing (optional)

Figure 1 — Injection station for hydrogen fuel gas

Requirements for the technical equipment for mixing hydrogen as an additive gas into the gas flow of the gas transmission and distribution system are not covered by this document. However, requirements for the resulting gas mixture are specified in 5.2, which specifies requirements for the operation of the injection station.

This document represents the recommendations at the time of its preparation. This document does not apply to injection stations operating prior to the publication of this document.

This document specifies common basic principles for gas infrastructure. Users of this document are expected to be aware that more detailed national standards and/or codes of practice can exist in the CEN member countries. This document is intended to be applied in association with these national standards and/or codes of practice setting out the above-mentioned basic principles.

In the event of terms of additional requirements in national legislation/regulation than in this document, CEN/TR 13737 (all parts) illustrates these terms.

CEN/TR 13737 (all parts) gives:

- legislation/regulations applicable in a member state;
- if appropriate, more restrictive national requirements;
- a national contact point for the latest information.

2 Normative references

The following documents are referred to in the text in such a way that some or all of their content constitutes requirements of this document. For dated references, only the edition cited applies. For undated references, the latest edition of the referenced document (including any amendments) applies.

EN 1594, *Gas infrastructure - Pipelines for maximum operating pressure over 16 bar - Functional requirements*

EN 12007-1, *Gas infrastructure - Pipelines for maximum operating pressure up to and including 16 bar - Part 1: General functional requirements*

EN 16726, *Gas infrastructure - Quality of gas - Group H*

EN 60079-10-1, *Explosive atmospheres - Part 10-1: Classification of areas - Explosive gas atmospheres*

prEN 17928-1, *Gas infrastructure - Injection stations - Part 1: General requirements*

3 Terms, symbols, units, and abbreviations

For the purposes of this document, the following terms and definitions apply.

ISO and IEC maintain terminology databases for use in standardization at the following addresses:

- ISO Online browsing platform: available at <https://www.iso.org/obp>
- IEC Electropedia: available at <https://www.electropedia.org/>

3.1

permeation

flow of a gas through another (usually solid) material by diffusion without a defect or opening of the latter

Note 1 to entry: To be distinguished from leak flow, which is not based on diffusion.

3.2

embrittlement

deleterious changes in the ductility properties of a metal that exposure to hydrogen can produce

[SOURCE: ISO/TR 15916]

4 General requirements

4.1 Specific requirements for hydrogen injection stations

The requirements on injection stations of prEN 17928-1 shall apply, observing the hydrogen-specific requirements in accordance with relevant pipework and product technical standard.

For further information, see IGC Doc 15/21/E, IGC Doc 122/18/E, ISO/TR 15916 and CEN/TR 17797.

prEN 17928-3:2023**4.2 Coordination and definition of interfaces**

Some of the areas that require coordination, which are not covered by the requirements specified in prEN 17928-1, include:

- the minimum requirements (grid code) of the gas grid operator;
- the maximum permissible, application-specific hydrogen content given by national regulation and the grid code of the downstream network;
 - with reference to the end-use (see EN 16726);
 - with reference for the downstream network (see EN 16726);
- avoidance of pipeline sections with oscillating flows and insufficient mixing with impermissible enrichment of hydrogen;
- the actual amount of hydrogen in the grid and injection from other sources;
- gas property measurement;
- hydrogen losses with reference to hazardous areas classification requirements.

4.3 Requirements on the properties of hydrogen fuel gas**4.3.1 General**

The operator shall define the relevant properties (metrological, chemical, calorific value, etc.) for the hydrogen fuel gas to be injected based on national regulation; in particular, the minimum and maximum amounts of hydrogen fuel gas injection shall be defined.

4.3.2 Injection for hydrogen fuel gas in methane-based grids

Maximum hydrogen content shall be stated.

NOTE National regulations can exist which can be more restrictive than those requirements observed in EU regulations.

4.3.3 Requirements for injection into dedicated hydrogen grids

Higher requirements for dedicated hydrogen grids can apply according to the grid code of the downstream operator.

4.4 Explosion protection

Explosion protection requirements shall be observed during station construction and operation, taking into account all hydrogen-specific hazards. Hazardous areas shall be classified in zones in accordance with EN 60079-10-1 or other recognized standards.

NOTE National regulations can exist.

A hydrogen safety data sheet shall be provided. Table 1 lists the safety-relevant technical properties of hydrogen with respect to explosion protection.

Table 1 — Safety-relevant technical properties of hydrogen

Lower explosive limit — LEL	4,0 Vol.-%
Upper explosive limit — UEL	75,6 Vol.-%
Ignition temperature	560 °C
Density	0,0899 kg/m ²
Density/air ratio	0,07
Temperature class	T1
Explosion group	IIC
Ignition energy	0,016 mJ

5 Operational functions

5.1 General

For operational functions, see prEN 17928-1.

5.2 Mixing hydrogen fuel gas with other gases

5.2.1 Homogeneity of the gas flow

When feeding hydrogen into a gas transmission or distribution system other than hydrogen, homogeneous mixing of hydrogen with the main gas shall be achieved at the nearest exit point or the next branching in the flow direction after the injection point.

The network operator shall ensure a sufficiently homogeneous mixture of hydrogen with the main gas.

The homogeneity of the mixture depends e.g. on pressures, flow velocities, design and dimensions of the injection point as well as the gas compositions, if no static mixer or similar is used.

When hydrogen is mixed with a T-joint, it can be shown by numeric simulations that after 500 times the diameter of the pipe of the main gas stream, the resulting gas is sufficiently homogenous [1] provided that the following conditions are met:

- volumetric flow ratio of the volumetric flow of hydrogen V_{H_2} to the volumetric flow of the main gas V_{MG} of $V_{H_2}/V_{MG} \leq 0,3$;
- ratio of the diameter d of the injection line to the diameter D of the main gas line: $d/D < 0,2$;
- gas flow velocity of the main gas stream $\geq 0,5$ m/s;
- injection speed of the hydrogen ≥ 5 m/s;
- Reynolds number of the main gas stream > 2300 (turbulent flow).

5.2.2 Control of the hydrogen content

The hydrogen content in the homogeneous mixture shall be measured by the network operator at the nearest calibrated measuring point or at the next branching of the flow of the mixed gas in the flow direction after the injection point.

Inadmissible hydrogen accumulations in the gas transportation or distribution system, as can occur for example in the case of shuttle operation [reverse flow] of the base gas, shall be avoided.

prEN 17928-3:2023

The network operator provides a suitable measurement signal to control the feed-in quantity. The requirements with regard to the technical specification, the required safety level and the temporal resolution shall be agreed between the network operator and the operator of the feeding station.

6 Overall safety requirements and protection against inadmissible operating modes

For overall safety requirements, see prEN 17928-1.

7 Specific requirements for systems and components**7.1 Key parameters for material selection****7.1.1 General**

The parameters given in the following subclauses, if in contact with the gas, shall be considered for all pressure containing parts of the injection station.

7.1.2 Hydrogen embrittlement (metallic materials)

Higher strength materials (tensile strength 800 N/mm² or higher) shall not be used in order to avoid hydrogen-induced stress corrosion cracking.

The required wall thicknesses should be calculated in accordance with the provisions of EN 15001-1. Consideration of the influence of the crack growth rate under hydrogen atmosphere is described in ASME B 31.12. It is recommended to construct and operate the station so that station components and connecting pipelines can be assumed to be mainly under static load.

7.1.3 Hydrogen permeation

The hydrogen permeation for metallic materials is negligible. Non-metallic materials require a specific investigation.

7.1.4 Requirements on hydrogen injection stations**7.2 Systems****7.2.1 Monitoring of ambient atmosphere**

The operator shall define, based on a hazard analysis and evaluation, whether or not ambient atmosphere monitoring and, if applicable, other protective measures are necessary in hazardous areas.

7.2.2 Metrological requirements

For metrological requirements, see prEN 17928-1. In particular, determining the energy amount of the injected hydrogen and the calorific value at the relevant discharge points of the gas supply grid shall be taken into account.

7.3 Components**7.3.1 Requirements on buried pipelines**

The requirements in EN 12007-1 and/or EN 1594 shall apply, observing the hydrogen-specific requirements.

Adequate organisational and operational or, if applicable, technical measures shall be taken to ensure that leaks are detected, and the integrity of service lines remains intact. These measures shall be based