



Standard Test Method for Using a Cone Calorimeter to Determine Fire-Test-Response Characteristics of Insulating Materials Contained in Electrical or Optical Fiber Cables¹

This standard is issued under the fixed designation D6113; the number immediately following the designation indicates the year of original adoption or, in the case of revision, the year of last revision. A number in parentheses indicates the year of last reapproval. A superscript epsilon (ϵ) indicates an editorial change since the last revision or reapproval.

1. Scope*

1.1 This is a fire-test-response standard.

1.2 Several fire-test-response characteristics, including the time to sustained flaming, heat release rate, total heat released, effective heat of combustion, and specific extinction area; are measured or calculated by this test method at a constant radiant heating flux. For specific limitations see also 5.7 and Section 6.

1.3 The tests are conducted by burning the electrical insulating materials contained in electrical or optical fiber cables when the cable test specimens, excluding accessories, are subjected to radiant heat.

1.4 *This standard measures and describes the response of materials, products, or assemblies to heat and flame under controlled conditions, but does not by itself incorporate all factors required for fire hazard or fire risk assessment of the materials, products or assemblies under actual fire conditions.*

1.5 The values stated in SI units are to be regarded as the standard. The values given in parentheses are for information only.

1.6 *This standard does not purport to address all of the safety concerns, if any, associated with its use. It is the responsibility of the user of this standard to establish appropriate safety and health practices and determine the applicability or regulatory limitations prior to use. For specific precautionary statements, see Section 7.*

2. Referenced Documents

2.1 *ASTM Standards:*²

D618 Practice for Conditioning Plastics for Testing

D1711 Terminology Relating to Electrical Insulation

D5424 Test Method for Smoke Obscuration of Insulating Materials Contained in Electrical or Optical Fiber Cables

When Burning in a Vertical Cable Tray Configuration

D5485 Test Method for Determining the Corrosive Effect of Combustion Products Using the Cone Corrosimeter

D5537 Test Method for Heat Release, Flame Spread, Smoke Obscuration, and Mass Loss Testing of Insulating Materials Contained in Electrical or Optical Fiber Cables When Burning in a Vertical Cable Tray Configuration

E176 Terminology of Fire Standards

E691 Practice for Conducting an Interlaboratory Study to Determine the Precision of a Test Method

E906 Test Method for Heat and Visible Smoke Release Rates for Materials and Products Using a Thermopile Method

E1354 Test Method for Heat and Visible Smoke Release Rates for Materials and Products Using an Oxygen Consumption Calorimeter

E1474 Test Method for Determining the Heat Release Rate of Upholstered Furniture and Mattress Components or Composites Using a Bench Scale Oxygen Consumption Calorimeter

2.2 *CSA Standard:*

CSA C22.2 No. 0.3, FT4, Vertical Flame Tests: Cables in Cable Trays, Section 4.11.4 in C22.2 No. 0.3, Test Methods for Electrical Wires and Cables³

2.3 *IEC Standards:*

IEC 60695-4 Fire Hazard Testing, Part 4: Terminology Concerning Fire Tests⁴

IEC 60695-5-2 Fire Hazard Testing, Part 5: Assessment of Potential Corrosion Damage by Fire Effluent - Section 2: Guidance on the Selection and Use of Test Methods⁴

2.4 *IEEE Standard:*

IEEE 1202 Standard for Flame Testing of Cables for Use in Cable Tray in Industrial and Commercial Occupancies, IEEE Standard 1202⁵

2.5 *ISO Standards:*

¹ This test method is under the jurisdiction of ASTM Committee D09 on Electrical and Electronic Insulating Materials and is the direct responsibility of Subcommittee D09.21 on Fire Performance Standards.

Current edition approved July 1, 2009. Published August 2009. Originally approved in 1997. Last previous edition approved in 2003 as D6113 – 03. DOI: 10.1520/D6113-09.

² For referenced ASTM standards, visit the ASTM website, www.astm.org, or contact ASTM Customer Service at service@astm.org. For *Annual Book of ASTM Standards* volume information, refer to the standard's Document Summary page on the ASTM website.

³ Available from Canadian Standards Association (CSA), 5060 Spectrum Way, Mississauga, ON L4W 5N6, Canada, http://www.csa.ca.

⁴ Available from International Electrotechnical Commission (IEC), 3 rue de Varembe, Case postale 131, CH-1211, Geneva 20, Switzerland, http://www.iec.ch.

⁵ Available from Institute of Electrical and Electronics Engineers, Inc. (IEEE), 445 Hoes Ln., P.O. Box 1331, Piscataway, NJ 08854-1331, http://www.ieee.org.

*A Summary of Changes section appears at the end of this standard.

ISO 13943 Fire Safety: Vocabulary⁶

ISO 11907-4 Plastics—Smoke Generation—Determination of the Corrosivity of Fire Effluents—Part 4: Dynamic Decomposition Method Using a Conical Radiant Heater⁶

2.6 *NFPA Standard:*

NFPA 262 Standard Method of Test for Flame Travel and Smoke of Wires and Cables for Use in Air-Handling Spaces⁷

2.7 *OSHA Standard:*

OSHA 191.1450 Occupational Exposure to Hazardous Chemicals in Laboratories⁸

2.8 *UL Standards:*

ANSI/UL 1581 Reference Standard for Electrical Wires, Cables, and Flexible Cords⁹

ANSI/UL 1666 Standard Test for Flame Propagation Height of Electrical and Optical-Fiber Cables Installed Vertically in Shafts⁹

ANSI/UL 1685 Standard Vertical Tray Fire Propagation and Smoke Release Test for Electrical and Optical Fiber Cables⁹

3. Terminology

3.1 Definitions:

3.1.1 For definitions of terms used in this test method and associated with fire issues use Terminology **E176**, **ISO 13943** and **IEC 60695-4**. Where differences exist in definitions, those contained in Terminology **E176** shall be used. Use Terminology **D1711** for definitions of terms used in this test method and associated with electrical insulation materials.

3.2 Definitions of Terms Specific to This Standard:

3.2.1 *cone calorimeter, n*—the apparatus which is used in Test Method **E1354** to determine heat release rate, by the principle of oxygen consumption calorimetry, and other fire-test-response characteristics.

3.2.2 *effective heat of combustion, n*—the ratio of the measured heat release to the mass loss, under specified test conditions.

3.2.2.1 *Discussion*—The effective heat of combustion is a function of the test conditions, including heating flux, exposure time and test specimen geometry.

3.2.3 *heat release rate, n*—the calorific energy released per unit time by the combustion of a material under specified test conditions.

3.2.4 *heating flux, n*—the prescribed incident power per unit area of test specimen, the power being imposed externally from the heater onto the test specimen at the initiation of the test.

3.2.4.1 *Discussion*—The test specimen, once ignited, is also heated by its own flame.

3.2.5 *ignitability, n*—the measure of the ease with which a specimen can be ignited due to the influence of an external energy source, under specified test conditions.

3.2.6 *net heat of combustion, n*—the quantity of heat released by the complete combustion of a unit mass of the material, the water produced being in the vapor state.

3.2.7 *orientation, n*—the plane in which the exposed face of the test specimen is located during testing, which is horizontal facing up for this test.

3.2.8 *oxygen consumption principle, n*—the expression of the relationship between the mass of oxygen consumed during combustion and the heat released.

3.2.9 *smoke obscuration, n*—the reduction in visibility due to the smoke.

3.2.10 *specific extinction area, n*—a measure of smoke obscuration potential per unit mass lost, determined as the product of the extinction coefficient and the volumetric mass flow rate, divided by the mass loss rate.

3.2.11 *sustained flaming, n*—existence of flame on or over the surface of the test specimen for periods of 4 s or more.

3.2.11.1 *Discussion*—Flaming of less than 4 s duration is identified as flashing or transitory flaming.

3.2.12 *total heat released, n*—integrated value of the rate of heat release, for a specified time period.

4. Summary of Test Method

4.1 All fire-test-response characteristics in this test method are determined using the apparatus and procedures described in Test Method **E1354**.

4.2 The oxygen consumption principle, used in this test method, is based on the observation that, generally, the net heat of combustion is directly related to the amount of oxygen required for combustion (**1**).¹⁰ Approximately 13.1 MJ of heat are released per 1 kg of oxygen consumed. Test specimens in this test method are burned in ambient air conditions, while being subjected to a prescribed external heating flux. (See also **X5.1**).

4.3 The heat release is determined by the measurement of the oxygen consumption, as determined by the oxygen concentration and the flow rate in the combustion product stream, as described in Test Method **E1354**.

4.4 The primary measurements are oxygen concentration and exhaust gas flow rate. Additional measurements include the time to sustained flaming, the smoke obscuration generated, the mass loss rate, and the effective heat of combustion. Ignitability is determined by measuring the time from initial exposure to time of sustained flaming of the test specimen.

4.5 A cone calorimeter is used to measure the consumption of oxygen during this test; heat release is then calculated, based on the oxygen consumption principle. The test specimen is mounted horizontally and a spark ignition source is employed.

5. Significance and Use

5.1 This test method is used to determine the heat release rate and a number of other fire-test-response characteristics as

⁶ Available from International Organization for Standardization (ISO), 1, ch. de la Voie-Creuse, Case postale 56, CH-1211, Geneva 20, Switzerland, <http://www.iso.ch>.

⁷ Available from National Fire Protection Association (NFPA), 1 Batterymarch Park, Quincy, MA 02169-7471, <http://www.nfpa.org>.

⁸ Available from Occupational Safety and Health Administration (OSHA), 200 Constitution Ave., NW, Washington, DC 20210, <http://www.osha.gov>.

⁹ Available from Underwriters Laboratories (UL), 333 Pfingsten Rd., Northbrook, IL 60062-2096, <http://www.ul.com>.

¹⁰ The boldface numbers given in parentheses refer to a list of references at the end of this test method.

a result of exposing insulating materials contained in electrical or optical cables to a prescribed heating flux in the cone calorimeter apparatus.

5.2 Quantitative heat release measurements provide information that is potentially useful for design of electrical or optical cables, and product development.

5.3 Heat release measurements provide useful information for product development by giving a quantitative measure of specific changes in fire performance caused by component and composite modifications. Heat release data from this test method will not be predictive of product behavior if the product will not spread flame over its surface under the fire exposure conditions of interest.

5.4 The fire-test-response characteristics determined by this test method are affected by the thickness of the material used as test specimen, whether as a plaque or as coating on a wire or cable. The diameter of the wire or cable used will also affect the test results.

5.5 A radiant exposure is used as an energy source for this test method. This type of source has been used for comparison with heat release rate and flame spread studies of insulating materials constructed into cables when burning in a vertical cable tray configuration (Test Methods [D5424](#) and [D5537](#)) (2-9). No definitive relationships have been established.

5.6 The value of heat release rate corresponding to the critical limit between propagating cable fires and non-propagating fires is not known.

5.7 This test method does not determine the net heat of combustion.

5.8 It has not been demonstrated that this test method is capable of predicting the response of electrical or optical fiber cables in a full scale fire. In particular, this test method does not address the self-extinguishing characteristics of the cables in a full scale fire.

6. Test Limitations

6.1 If during the test of one or more of the three replicate test specimens, any of the following unusual behavior occurs: molten material overflows the specimen holder trough; a test specimen is displaced from the zone of controlled irradiance (explosive spalling); or the test specimen swells sufficiently prior to ignition to touch the spark plug or swells up to the plane of the heater base during combustion; then test an additional specimen of the identical preconditioned test specimens in the test mode in which the unusual behavior occurred. Do not incorporate data obtained from the tests noted above, yielding inadequate results, in the averaged data but report the occurrence. This test method is not suitable if more than three out of six test specimens tested show any of the above characteristics.

6.2 The applicability of this test method to smoldering ignition of cables has not been demonstrated. This test method is not suitable for incident heat fluxes below 10 kW/m².

6.3 The validity of the results of this test method for a particular scenario depends on the conditions under which the tests are conducted. In particular, it has been established that the use of a different heating flux will change relative results.

7. Safety Precautions

7.1 The test procedures involve high temperatures and combustion processes. Hazards therefore exist for burns, ignition of extraneous objects or clothing, and inhalation of combustion products. The operator must take appropriate precautions during the insertion and removal of the test specimens, for example, by using protective gloves. Do not touch either the cone heater or the associated fixtures while hot, except with the use of appropriate protective gear.

7.2 Vent the combustion products flowing through the exposure chamber through a properly designed exhaust system. An adequate method of venting the combustion products captured in the exposure chamber during the test is through an OSHA approved smoke hood¹¹ at the end of a test.

7.3 Check the exhaust system for proper operation before testing and discharge into a building exhaust system with adequate capacity. Make provisions for collecting and venting any combustion products that for whatever reason are not collected by the exhaust system of the apparatus.

8. Test Specimen

8.1 Size and Preparation:

8.1.1 The types of test specimens permitted are (a) materials in the form of a flat plaque, or (b) electrical insulating materials contained in electrical or optical cables. The test specimen shall be 100 ± 2 by 100 ± 2 mm (approximately 4 ± 0.08 by 4 ± 0.08 in.) in size, or as close to that as possible. Fill the specimen holder as completely as possible with the cable pieces. Make the thickness of a material test specimen in a flat plaque the same as that of the end use of the material in cable construction. If the end use thickness is not known, or if the test is conducted for other purposes, use a thickness of 6.3 ± 0.5 mm (approximately 0.25 ± 0.02 in.). Ensure that the overall characteristics of the test specimens are those of the wire or cable in its end use (wall thickness and overall diameter).

NOTE 1—Overall test specimen thicknesses of less than 2 mm (approximately 0.08 in.) are not recommended, because potential testing errors become larger.

8.1.2 For test specimens of materials in flat plaques, cut the test specimen to a size of 100 ± 2 by 100 ± 2 mm (approximately 4 ± 0.08 by 4 ± 0.08 in.). Wrap the test specimen in a single layer of aluminum foil (0.03 to 0.04 mm (1.2 to 1.6 × 10⁻³ in.) thick), shiny side towards the test specimen. Place the edge frame over the test specimen and cut the aluminum foil along the open edges at the top of the edge frame to expose the test specimen. Remove the test specimen from the edge frame, place a grid on the exposed face of the test specimen and insert both the test specimen and the grid into the edge frame.

8.1.3 For test specimens of electrical insulating materials contained in electrical or optical fiber cables, cut the cables to 100 ± 2 mm (approximately 4 ± 0.08 in.) lengths to fill the

¹¹ Use a smoke hood in compliance with OSHA regulations for Occupational Exposure to Hazardous Chemicals in Laboratories - 191.1450.

specimen holder. Seal the ends using an adhesive cement.¹² Apply the adhesive cement to the cable ends such that there are no visible air holes in the coating and that the cement does not overlap the cable ends. Wrap the cable lengths in a single layer of aluminum foil. Place the edge frame over the cable test specimens and cut the aluminum foil along the open edges at the tip of the edge frame and expose the test specimens. Remove the test specimens from the edge frame, place a grid on the exposed face of the test specimens and insert both the test specimen and the grid into the edge frame.

8.1.4 Optionally, for test specimens of electrical insulating materials contained in electrical or optical fiber cables, cut the cables to 100 ± 2 mm (approximately 4 ± 0.08 in.) lengths to fill the specimen holder, without sealing the ends. Wrap the cable lengths in a single layer of aluminum foil. Place the edge frame over the cable test specimens and cut the aluminum foil along the open edges at the tip of the edge frame and expose the test specimens. Remove the test specimens from the edge

¹² The sole source of supply of the adhesive cement known to the committee at this time is Sauereisen Insa-Lute, available from Sauereisen, 160 Gamma Drive, Pittsburgh, PA 15238. If you are aware of alternative suppliers, please provide this information to ASTM International Headquarters. Your comments will receive careful consideration at a meeting of the responsible technical committee,¹ which you may attend.

frame, place a grid on the exposed face of the test specimens and insert both the test specimen and the grid into the edge frame.

NOTE 2—The objective of sealing the cable ends is to prevent gas evolution through such ends, that is not to be expected when a full length of cable is exposed to a fire in actual use. Moreover, the same method of test specimen preparation is used in Test Method D5485, and the draft international test method ISO CD 11907-4, mentioned in IEC 60695-5-2. However, it is unclear whether the results of the cone calorimeter testing are more meaningful with the cable ends sealed or unsealed.

8.2 Condition the test specimens in accordance with Practice D618 to moisture equilibrium (constant weight) at an ambient temperature of $23 \pm 3^\circ\text{C}$ and a relative humidity of $50 \pm 5\%$.

8.3 Specimen Holder and Mounting:

8.3.1 Two specimen holders are described, one in 8.3.2 and one in 8.3.3.

8.3.2 The first specimen holder is shown in Fig. 1. The bottom is constructed from 2.4-mm nominal stainless steel and has outside dimensions of 106 by 106 by 25-mm height (± 2 mm).

8.3.2.1 Optionally, use an edge frame and a grid. The optional edge frame (Fig. 2) is constructed from 1.9-mm nominal stainless steel with outside dimensions of 111 by 111

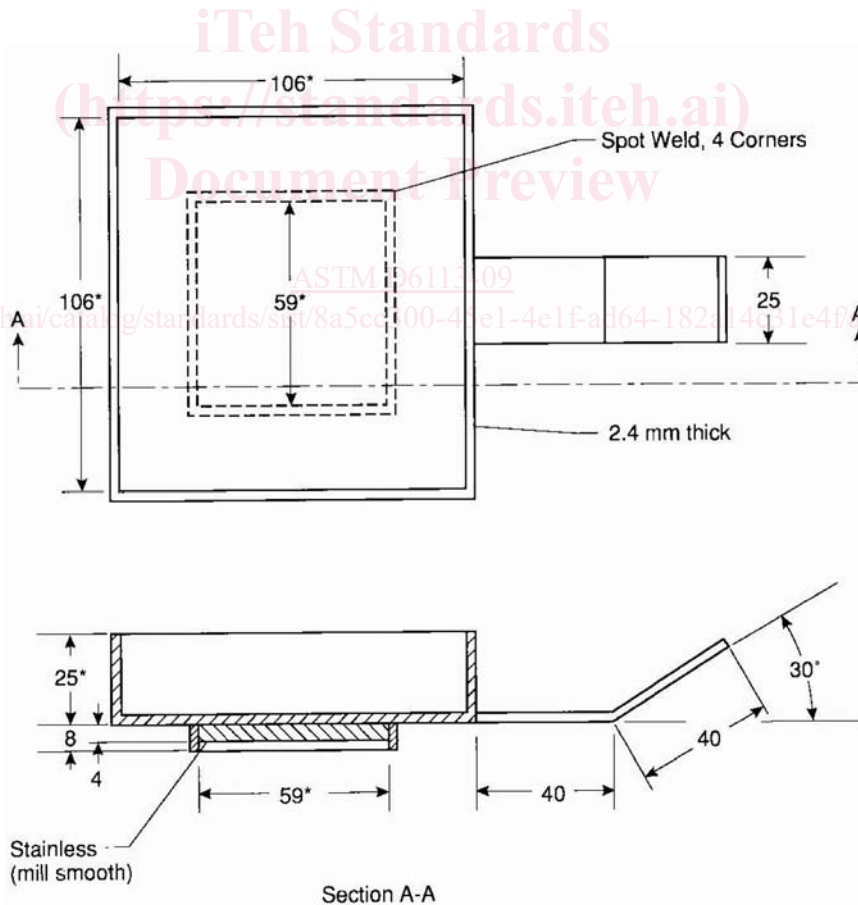

NOTE 1—All dimensions are in millimetres.
NOTE 2—* Indicates a critical dimension.

FIG. 1 New Specimen Holder

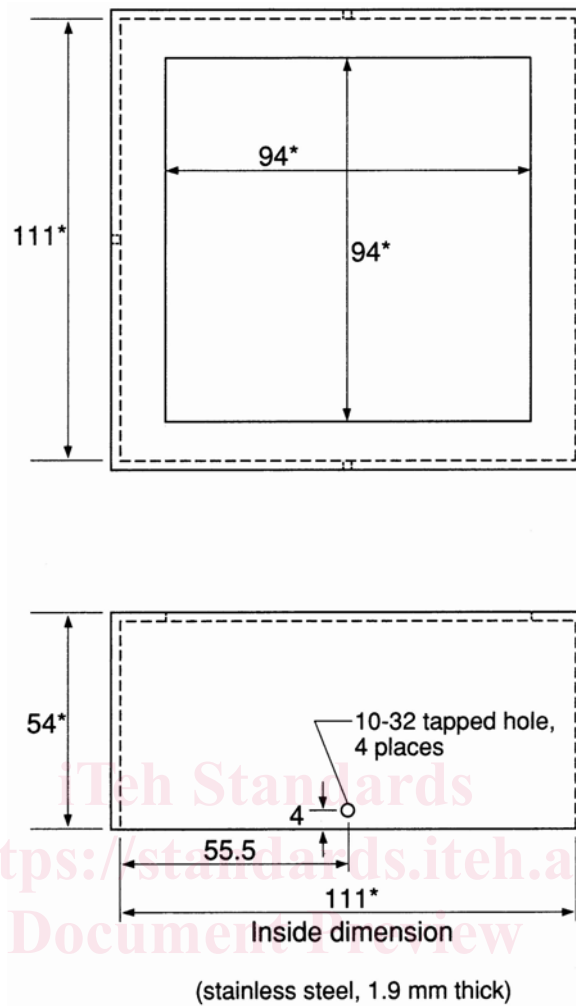

NOTE 1—All dimensions are in millimetres.

NOTE 2—* Indicates a critical dimension.

FIG. 2 Optional Edge Frame

by 54-mm height (± 2 mm). The optional grid (Fig. 3) is constructed from 1-mm nominal stainless steel and has dimensions of 109 by 109 mm (± 2 mm). The optional grid has 2-mm ribs and the openings in the center are 20 by 20 mm (± 1 mm).

8.3.2.2 The distance between the bottom surface of the cone heater and the top of the specimen shall be adjusted to be 25 \pm 1 mm, except as indicated in (1) below.

(1) The distance between the bottom surface of the cone heater and the top of the specimen shall be adjusted to 60 mm in the case of those dimensionally unstable materials that have the potential to intumesce or deform to such an extent that they are likely to make physical contact with either (a) the spark plug before ignition or (b) the underside of the cone heater after ignition.

(2) If a test is conducted in accordance with the specimen mounting in (1) above (a 60 mm distance), the heat flux calibration shall be performed with the heat flux meter positioned 60 mm below the cone heater base plate.

(3) If a test has been conducted with a distance of 25 mm and the type of physical contact described in (1) above has

occurred, that test shall be deemed invalid and the distance shall be adjusted to 60 mm for future tests.

8.3.2.3 Intumescent materials. The testing technique to be used when testing intumescent specimens in the horizontal orientation shall be documented in the test report. Options include those shown in (1)–(4) below.

(1) Use a retainer frame or edge frame (Fig. 2). The edge frame is used to reduce unrepresentative edge burning of specimens. The edge frame is constructed from 1.9-mm nominal stainless steel with outside dimensions of 111 by 111 by 54-mm height (± 2 mm).

(2) Use a wire grid (Fig. 3). The wire grid is used for retaining specimens prone to delamination and is suitable for several types of intumescent specimens. The grid is constructed from 1-mm nominal stainless steel and has dimensions of 109 by 109 mm (± 2 mm). The grid has 2-mm ribs and the openings in the center are 20 by 20 mm (± 1 mm).

(3) Use a separation distance between the cone base plate and the upper specimen surface of 60 mm instead of 25 mm. This technique is suitable for those dimensionally unstable

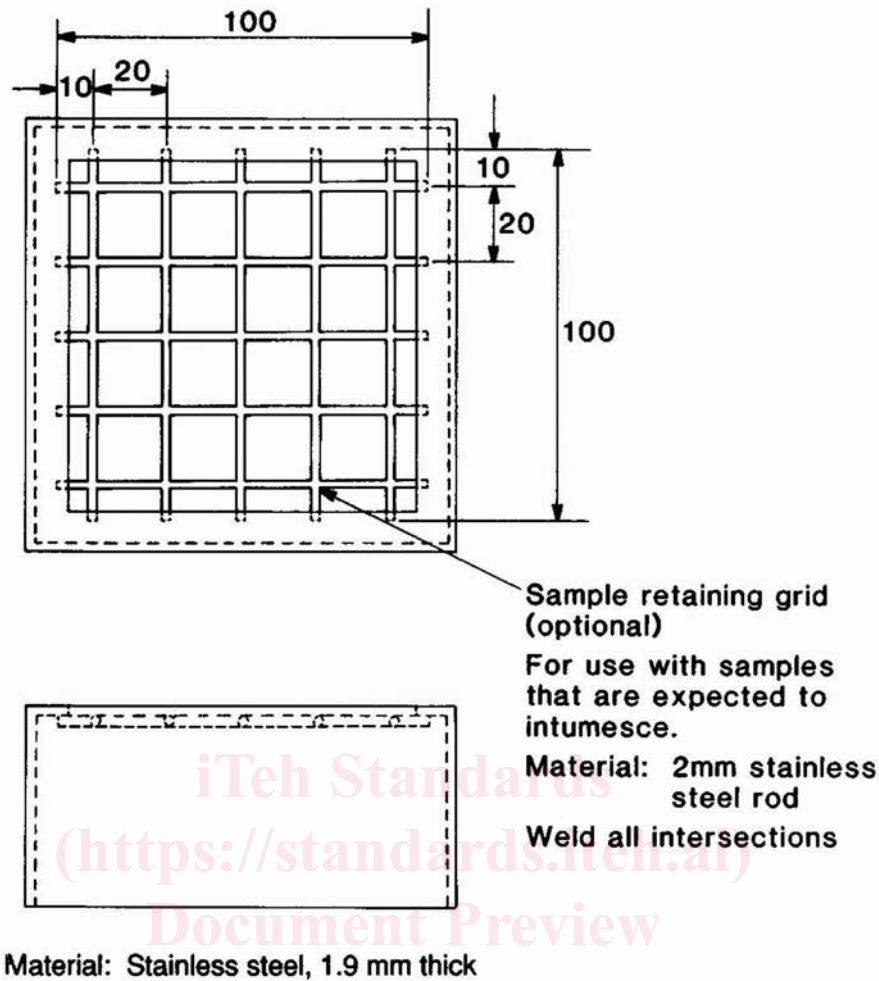

NOTE 1—All dimensions are in millimetres.

FIG. 3 Optional Grid

materials that have the potential to intumesce or deform to such an extent that they are likely to make physical contact with either (a) the spark plug before ignition or (b) the underside of the cone heater after ignition.

(4) Use a special mounting procedure suitable for the specimen to be tested.

8.3.2.4 The bottom of the specimen holder shall be lined with a layer of a low-density (nominal density 65 kg/m^3) refractory fiber blanket with a thickness of at least 13 mm.

8.3.3 A second specimen holder is shown in Fig. 4.

8.3.3.1 The second specimen holder consists of the bottom, the edge frame, retaining pins and wire grid as shown in Fig. 4. The bottom is constructed from 2 mm nominal stainless steel and has outside dimensions of $111 \text{ by } 111 \pm 2 \text{ by } 24 \pm 2 \text{ mm}$ height. The grid is constructed from 1 mm nominal stainless steel and has dimensions of $109 \pm 2 \text{ by } 109 \pm 2 \text{ mm}$. The grid has 1 mm ribs and the openings in the center are $19 \pm 1 \text{ by } 19 \pm 1 \text{ mm}$. The edge frame is constructed from 2 mm nominal stainless steel with outside dimensions of $116 \pm 2 \text{ by } 116 \pm 2 \text{ mm}$ height. The frame has an 8 mm lip on the top to provide an opening of $100 \text{ by } 100 \text{ mm}$ on the top. There are two $3 \pm 0.5 \text{ mm}$ diameter by $130 \pm 3 \text{ mm}$ long retaining pins to lock the test specimen in the edge frame.

8.3.3.2 The bottom of the specimen holder shall be lined with a layer of a low density (nominal density 65 kg m^{-3}) ceramic fiber refractory blanket with thickness of at least 13 mm. If necessary, fill the edge frame below the test specimens with refractory blanket to the level of the retaining pins. Lock the assembly with retaining pins and place assembly on the bottom specimen holder. The distance between the bottom of the radiant heater and the top of the edge frame is adjusted to $25 \pm 1 \text{ mm}$ by using a sliding height adjustment.

9. Procedure

9.1 Preparation:

9.1.1 Calibrate the test apparatus in accordance with Test Method E1354. Position the cone heater for a horizontal specimen orientation and set the radiant heating flux level to the chosen value, with a tolerance of $\pm 1 \text{ kW/m}^2$.

9.1.2 Verify that the distance between the bottom of the cone heater baseplate and the top of the test specimen is 25 mm (approximately 1 in.).

9.1.3 Position the spark igniter at a distance of 13 mm above the test specimen surface.

NOTE 3—As stated in 6.1, if the test specimen comes in contact with the