**Traditional Chinese medicine —
Computerized tongue image analysis
system —**

**Part 4:
Peripheral visual instruments**

iTeh STANDARD PREVIEW
(standards.iteh.ai)
*Médecine traditionnelle chinoise — Système d'analyse d'images
numérisées de la langue —
Partie 4: Instruments visuels périphériques*

[ISO/TS 20498-4:2020](https://standards.iteh.ai/catalog/standards/sist/40dd7e39-ee84-4b36-a0c4-87e09ea0be5a/iso-ts-20498-4-2020)

<https://standards.iteh.ai/catalog/standards/sist/40dd7e39-ee84-4b36-a0c4-87e09ea0be5a/iso-ts-20498-4-2020>



iTeh STANDARD PREVIEW
(standards.iteh.ai)

ISO/TS 20498-4:2020
<https://standards.iteh.ai/catalog/standards/sist/40dd7e39-ee84-4b36-a0c4-87e09ea0be5a/iso-ts-20498-4-2020>



COPYRIGHT PROTECTED DOCUMENT

© ISO 2020

All rights reserved. Unless otherwise specified, or required in the context of its implementation, no part of this publication may be reproduced or utilized otherwise in any form or by any means, electronic or mechanical, including photocopying, or posting on the internet or an intranet, without prior written permission. Permission can be requested from either ISO at the address below or ISO's member body in the country of the requester.

ISO copyright office
CP 401 • Ch. de Blandonnet 8
CH-1214 Vernier, Geneva
Phone: +41 22 749 01 11
Email: copyright@iso.org
Website: www.iso.org

Published in Switzerland

Contents

	Page
Foreword	iv
1 Scope	1
2 Normative references	1
3 Terms and definitions	1
4 Performance	2
4.1 Colour reproduction.....	2
4.2 Display resolution.....	2
4.3 Distortion.....	2
4.4 Viewing environment.....	3
Annex A (informative) sRGB values of colour chart	5
Bibliography	6

iTeh STANDARD PREVIEW (standards.iteh.ai)

ISO/TS 20498-4:2020

<https://standards.iteh.ai/catalog/standards/sist/40dd7e39-ee84-4b36-a0c4-87e09ea0be5a/iso-ts-20498-4-2020>

Foreword

ISO (the International Organization for Standardization) is a worldwide federation of national standards bodies (ISO member bodies). The work of preparing International Standards is normally carried out through ISO technical committees. Each member body interested in a subject for which a technical committee has been established has the right to be represented on that committee. International organizations, governmental and non-governmental, in liaison with ISO, also take part in the work. ISO collaborates closely with the International Electrotechnical Commission (IEC) on all matters of electrotechnical standardization.

The procedures used to develop this document and those intended for its further maintenance are described in the ISO/IEC Directives, Part 1. In particular, the different approval criteria needed for the different types of ISO documents should be noted. This document was drafted in accordance with the editorial rules of the ISO/IEC Directives, Part 2 (see www.iso.org/directives).

Attention is drawn to the possibility that some of the elements of this document may be the subject of patent rights. ISO shall not be held responsible for identifying any or all such patent rights. Details of any patent rights identified during the development of the document will be in the Introduction and/or on the ISO list of patent declarations received (see www.iso.org/patents).

Any trade name used in this document is information given for the convenience of users and does not constitute an endorsement.

For an explanation of the voluntary nature of standards, the meaning of ISO specific terms and expressions related to conformity assessment, as well as information about ISO's adherence to the World Trade Organization (WTO) principles in the Technical Barriers to Trade (TBT), see www.iso.org/iso/foreword.html.

This document was prepared by Technical Committee ISO/TC 249, *Traditional Chinese medicine*.

A list of all parts in the ISO 20498 series can be found on the ISO website.

Any feedback or questions on this document should be directed to the user's national standards body. A complete listing of these bodies can be found at www.iso.org/members.html.

Traditional Chinese medicine — Computerized tongue image analysis system —

Part 4: Peripheral visual instruments

1 Scope

This document specifies the performance criteria of peripheral visual instruments in the computerized tongue image analysis system (CTIS), including colour reproduction, distortion and resolution.

2 Normative references

The following documents are referred to in the text in such a way that some or all of their content constitutes requirements of this document. For dated references, only the edition cited applies. For undated references, the latest edition of the referenced document (including any amendments) applies.

ISO/TS 20498-3, *Computerized tongue image analysis system — Part 3: Colour chart*

3 Terms and definitions (standards.iteh.ai)

For the purposes of this document, the following terms and definitions apply.

ISO and IEC maintain terminological databases for use in standardization at the following addresses:

— ISO Online browsing platform: available at <https://www.iso.org/obp>

— IEC Electropedia: available at <http://www.electropedia.org/>

3.1

peripheral visual instrument

device which includes computer display drive used in CTIS

Note 1 to entry: Display drive includes graphics, display drive software and related colour reproduction software

3.2

colour reproduction

ability to accurately reproduce the colour of the object

3.3

CIELAB colour difference

CIE1976 L*a*b* colour difference

ΔE_{ab}^*

difference between two colour stimuli defined as the Euclidean distance between the points representing them in L*a*b* colour space

[SOURCE: CIE 17.4:1987, 845-03-55]

3.4

display resolution

number of distinct pixels displayed in each dimension

3.5 distortion

shape deformation of the image versus object due to difference between magnification of centre and margin of image, usually expressed in absolute distortion or relative distortion

3.6 sRGB

colour space standardized by the IEC

[SOURCE: IEC 61966-2-1:1999]

4 Performance

4.1 Colour reproduction

The imaging device shall give accurate colour reproduction and reproduces the colour in the colour chart. The CIELAB colour difference ΔE^*_{ab} of single colour in the CIE L*a*b* colour space shall be no more than 5.

Conformity is checked by the following test:

Open the image file of the colour chart and display it on the peripheral visual instrument. The displayed image shall meet the requirements of ISO/TS 20498-3. Use colour spectrophotometer for testing; compare the real value with the specified value in ISO/TS 20498-3 according to the following formula to calculate the colour difference. The result shall be in accordance with the requirements.

$$\Delta E^*_{ab} = [(\Delta L^*)^2 + (\Delta a^*)^2 + (\Delta b^*)^2]^{1/2}$$

where ΔE^*_{ab} is the colour difference of the CIE L*a*b* colour space.

It is recommended that colour patches of primary colour (CMY), (RGB) and grey scales, including black and white colour patches, be used for calibration of the LCD monitor.

NOTE The characteristics of the colour chart are listed in [Annex A](#), Table A.1, for additional information.

4.2 Display resolution

Display resolution shall not be less than 1024 × 768 pixels at aspect ratio 4:3.

4.3 Distortion

The distortion shall not be larger than 1 % in both horizontal and vertical directions.

Step 1:

Place the concentric test card (as shown in [Figure 1](#)) perpendicular to the optical axis of the imaging device. The concentric test card consists of two concentric circles, with the diameters of the small and large circles being $d = 20 \text{ mm} \pm 0,1 \text{ mm}$ and $D = 100 \text{ mm} \pm 0,1 \text{ mm}$, respectively.

Step 2:

Take the image under a simulation environment which has the same working distance and working conditions as the real application. The test card shall be located at the centre of the field of view and, as far as possible, be filled with the entire view.

Step 3:

Measure the small circle diameter d_i ($i = 1, 2, \dots, 8$) and large circle diameter D_j ($j = 1, 2, \dots, 8$) (d_i and D_j can use length or pixels) every $22,5^\circ$.

Step 4:

Using the following formula, calculate the distortion. The result shall conform with the requirements of [4.3](#).

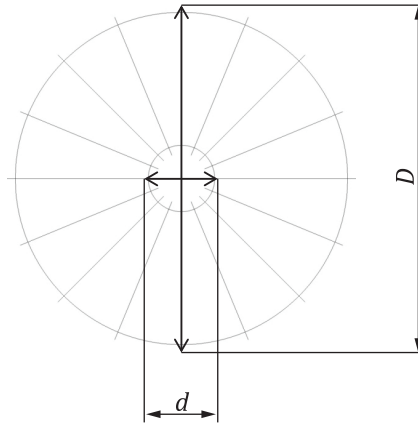

Key

- D diameter of large circle
- d diameter of small circle

iTech STANDARD PREVIEW
(standards.itech.ai)

Figure 1 — Concentric test card

$$V_j = \frac{|M_j - m|}{m} \times 100\% = \frac{|D_j - 5a|}{5a} \times 100\% \quad (j=1, 2, \dots, 8)$$

$$M_j = \frac{D_j}{D} \quad (j=1, 2, \dots, 8)$$

$$m = \frac{a}{d}$$

$$a = \frac{1}{8} \sum_{i=1}^8 d_i$$

where

- V_j is the ratio (%) of distortion of eight directions;
- M_j is the magnification of diameter of the large circle;
- m is the average magnification of diameter of the small circle;
- a is the average of diameter of the small circle;
- D_j is the diameter of the large circle on the display;
- d_i is the diameter of the small circle on the display.

4.4 Viewing environment

The sRGB viewing environment is shown in [Table 1](#).

Table 1 — sRGB viewing environment parameters

Condition	sRGB
Luminance level	80 cd/m ²
Adaptive white	x = 0,3127, y = 0,3291 (D65)
Image surround	20 % reflectance (medium grey)
Encoding ambient illuminance level	64 lux
Encoding ambient white point	x = 0,3457, y = 0,3585 (D50)
Encoding viewing flare	1,0 %
Typical ambient illuminance level	200 lux
Typical ambient white point	x = 0,3457, y = 0,3585 (D50)
Typical viewing flare	5,0 %

iTeh STANDARD PREVIEW
(standards.iteh.ai)

ISO/TS 20498-4:2020

<https://standards.iteh.ai/catalog/standards/sist/40dd7e39-ee84-4b36-a0c4-87e09ea0be5a/iso-ts-20498-4-2020>

Annex A (informative)

sRGB values of colour chart

Table A.1 — Name of colour patch and sRGB coordinates at CIE D65 and D50 illuminates

Number	Colour	R(D65)	G(D65)	B(D65)	R(D50)	G(D50)	B(D50)
1	Cyan	77	163	193	97	163	169
2	Magenta	190	108	151	198	106	131
3	Yellow	205	200	93	221	199	74
4	Red	184	77	72	192	76	60
5	Green	90	158	74	105	156	59
6	Blue	66	104	148	77	101	128
7	Black	48	48	48	53	48	40
8	Gray30	71	71	71	77	70	60
9	Gray40	94	94	94	102	93	80
10	Gray50	119	119	119	128	118	102
11	Gray60	145	145	145	156	143	124
12	White	226	226	226	243	224	196
13	Tongue#01	168	122	89	179	122	76
14	Tongue#02	177	154	131	187	152	112
15	Tongue#03	164	110	106	172	108	90
16	Tongue#04	97	77	81	103	76	69
17	Tongue#05	157	134	136	168	132	116
18	Tongue#06	105	64	70	109	62	59
19	Tongue#07	153	95	106	160	93	91
20	Tongue#08	176	95	98	183	93	82
21	Tongue#09	130	57	61	136	58	53
22	Tongue#10	147	58	62	150	56	50
23	Tongue#11	164	77	78	172	78	66
24	Tongue#12	181	111	93	189	107	78
Frame 1	White	198	198	198	213	196	171
Frame 2	Black	59	59	59	64	59	50