

SLOVENSKI STANDARD

SIST EN 14988:2017+A1:2020

01-april-2020

Nadomešča:
SIST EN 14988:2017

Otroški visoki stoli - Zahteve in preskusne metode (vključno z dopolnilom A1)

Children's high chairs - Requirements and test methods

Kinderhochstühle - Anforderungen und Prüfverfahren

Chaises hautes pour enfants - Exigences et méthodes d'essai

Ta slovenski standard je istoveten z: EN 14988:2017+A1:2020

ICS:

| | | |
|--------|----------------|------------------------|
| 97.140 | Pohištvo | Furniture |
| 97.190 | Otroška oprema | Equipment for children |

SIST EN 14988:2017+A1:2020 **en,fr,de**

iTeh STANDARD PREVIEW
(standards.iteh.ai)

Full standard:
<https://standards.iteh.ai/catalog/standards/sist/a559c130-b4dd-441a-957d-73b80e2ce26/sist-en-14988-2017a1-2020>

EUROPEAN STANDARD

EN 14988:2017+A1

NORME EUROPÉENNE

EUROPÄISCHE NORM

February 2020

ICS 97.140; 97.190

Supersedes EN 14988:2017

English Version

Children's high chairs - Requirements and test methods

Chaises hautes pour enfants - Exigences et méthodes
d'essai

Kinderhochstühle - Anforderungen und Prüfverfahren

This European Standard was approved by CEN on 24 April 2017 and includes Amendment 1 approved by CEN on 18 November 2019.

CEN members are bound to comply with the CEN/CENELEC Internal Regulations which stipulate the conditions for giving this European Standard the status of a national standard without any alteration. Up-to-date lists and bibliographical references concerning such national standards may be obtained on application to the CEN-CENELEC Management Centre or to any CEN member.

This European Standard exists in three official versions (English, French, German). A version in any other language made by translation under the responsibility of a CEN member into its own language and notified to the CEN-CENELEC Management Centre has the same status as the official versions.

CEN members are the national standards bodies of Austria, Belgium, Bulgaria, Croatia, Cyprus, Czech Republic, Denmark, Estonia, Finland, France, Germany, Greece, Hungary, Iceland, Ireland, Italy, Latvia, Lithuania, Luxembourg, Malta, Netherlands, Norway, Poland, Portugal, Republic of North Macedonia, Romania, Serbia, Slovakia, Slovenia, Spain, Sweden, Switzerland, Turkey and United Kingdom.



EUROPEAN COMMITTEE FOR STANDARDIZATION
COMITÉ EUROPÉEN DE NORMALISATION
EUROPÄISCHES KOMITEE FÜR NORMUNG

CEN-CENELEC Management Centre: Rue de la Science 23, B-1040 Brussels

Contents

| | Page |
|--|-----------|
| European foreword..... | 4 |
| 1 Scope | 5 |
| 2 Normative references | 5 |
| 3 Terms and definitions | 5 |
| 4 General | 6 |
| 4.1 Test conditions | 6 |
| 4.2 Application of forces | 6 |
| 4.3 Tolerances | 6 |
| 4.4 Test sequence | 7 |
| 4.5 Determination of the junction line | 7 |
| 5 Test equipment | 8 |
| 5.1 General | 8 |
| 5.2 Test mass A | 8 |
| 5.3 Impact hammer | 8 |
| 5.4 Large loading pad | 9 |
| 5.5 Small loading pad | 9 |
| 5.6 Stops | 10 |
| 5.7 Floor surface | 10 |
| 5.8 Beams | 10 |
| 5.9 Probes for finger entrapment | 10 |
| 5.10 Test mass B | 10 |
| 5.11 Small parts cylinder | 10 |
| 5.12 Small torso probe | 11 |
| 5.13 Test mass C | 11 |
| 5.14 Leg probe | 12 |
| 5.15 Wedge block | 12 |
| 5.16 Large head probe | 13 |
| 5.17 Impactor | 14 |
| 5.18 Wood block | 14 |
| 5.19 Feeler gauge | 14 |
| 5.20 Test mass D | 14 |
| 6 Chemical hazards - Migration of certain elements (see A.2) | 14 |
| 7 Thermal hazards (see A.3) | 15 |
| 8 Mechanical hazards (see A.4) | 15 |
| 8.1 Hazards caused by folding of the product | 15 |
| 8.2 Hazards caused by height adjustment | 16 |
| 8.3 Entrapment hazards (see A.4.1) | 17 |
| 8.4 Hazards caused by moving parts (see A.4.2) | 18 |
| 8.5 Entanglement hazards (see A.4.3) | 18 |
| 8.6 Choking and ingestion hazards (see A.4.4) | 19 |
| 8.7 Hazards caused by edges, corners and protruding parts (see A.4.6) | 21 |
| 8.8 Strength and durability hazards (Structural integrity, see A.4.7) | 21 |
| 8.9 Hazards from falls out of the high chair (see A.4.8) | 24 |
| 8.10 Suffocation hazards (see A.4.5) | 32 |

| | | |
|---|---|----|
| 8.11 | Castors and wheels (see A.4.9) | 32 |
| 8.12 | Stability (see A.A.4.10) | 34 |
| 9 | Marking and product information | 38 |
| 9.1 | General | 38 |
| 9.2 | Marking | 38 |
| 9.3 | Instructions for use | 39 |
| 9.4 | Purchase information | 39 |
| Annex A (informative) Rationales | | 41 |
| A.1 | Introduction | 41 |
| A.2 | Chemical hazards (see Clause 6) | 41 |
| A.3 | Thermal hazards (see Clause 7) | 41 |
| A.4 | Mechanical hazards (see Clause 8) | 41 |
| Annex B (informative) A- deviations | | 44 |
| Annex C (normative) Translations | | 46 |
| Bibliography | | 56 |

iTeh STANDARD PREVIEW
 (standards.iteh.ai)

Full standard:
<https://standards.iteh.ai/catalog/standards/sist/a559c130-b4dd-441a-957d-73b80e2ce26/sist-en-14988-2017/a1-2020>

EN 14988:2017+A1:2020 (E)**European foreword**

This document (EN 14988:2017+A1:2020) has been prepared by Technical Committee CEN/TC 364 "High Chairs", the secretariat of which is held by UNI.

This European Standard shall be given the status of a national standard, either by publication of an identical text or by endorsement, at the latest by August 2020, and conflicting national standards shall be withdrawn at the latest by February 2021.

Attention is drawn to the possibility that some of the elements of this document may be the subject of patent rights. CEN shall not be held responsible for identifying any or all such patent rights.

This document includes Amendment 1 approved by CEN on 2019-03-29.

This document supersedes A1 EN 14988-1:2017 A1.

The start and finish of text introduced or altered by amendment is indicated in the text by tags A1 A1.

This document has been prepared under a mandate given to CEN by the European Commission and the European Free Trade Association.

This document contains the following main modifications in comparison to the previous versions:

- EN 14988-1:2006+A1:2012 and EN 14988-2:2006+A1:2012 have been merged into one single document;
- complete review of the standard in a hazard base format;
- modifications necessary to comply with European Decision 2013/121/EU;
- addition of a dynamic strength test;
- inclusion of specific requirements for high chair with more than two castors/wheels;
- improvement of restraint system requirements to require a passive crotch restraint for products with a horizontal component in front of the baby.

According to the CEN-CENELEC Internal Regulations, the national standards organisations of the following countries are bound to implement this European Standard: Austria, Belgium, Bulgaria, Croatia, Cyprus, Czech Republic, Denmark, Estonia, Finland, France, Germany, Greece, Hungary, Iceland, Ireland, Italy, Latvia, Lithuania, Luxembourg, Malta, Netherlands, Norway, Poland, Portugal, Republic of North Macedonia, Romania, Serbia, Slovakia, Slovenia, Spain, Sweden, Switzerland, Turkey and the United Kingdom.

1 Scope

This European Standard specifies safety requirements for free standing children's high chairs that elevate children to dining table height usually for the purposes of feeding or eating. Children's high chairs are for children up to 3 years of age who are capable of sitting unaided.

With the exception of special high chairs for medical purposes, this standard applies to children's high chairs for domestic and non-domestic use.

NOTE If a children's high chair has to or can be converted into other functions, additional European Standards may apply.

2 Normative references

The following documents, in whole or in part, are normatively referenced in this document and are indispensable for its application. For dated references, only the edition cited applies. For undated references, the latest edition of the referenced document (including any amendments) applies.

EN 71-2:2011+A1:2014, *Safety of toys - Part 2: Flammability*

EN 71-3, *Safety of toys - Part 3: Migration of certain elements*

EN 13210, *Child use and care articles - Children's harnesses, reins and similar type articles - Safety requirements and test methods*

ISO 7619-1, *Rubber, vulcanized or thermoplastic - Determination of indentation hardness - Part 1: Durometer method (Shore hardness)*

3 Terms and definitions

For the purposes of this document, the following terms and definitions apply.

3.1

active restraint system

system where the carer performs an action to ensure that the child is secured in the restraint system

3.2

passive restraint system

system where the carer does not perform an action to ensure that the child is secured in the restraint system

3.3

crotch restraint

device passing between the legs of the child and preventing the child from slipping forwards out of the high chair

3.4

waist restraint

rigid or flexible device(s), which when fastened, goes from one side of the high chair to the other passing in front of the child's waist or surrounding the child's waist

3.5

shoulder restraint

device passing over the shoulders and connecting either to the crotch restraint or to the waist restraint

EN 14988:2017+A1:2020 (E)**3.6****locking device**

component that maintains part(s) of the product in the position of use

EXAMPLE Latch, a hook, an over centre lock.

3.7**operating device**

part of the locking mechanism(s) or parking device(s) designed to be activated by the carer by one or several action(s)

3.8**parking device**

device intended to prevent rolling of castors/wheels

3.9**locking mechanism**

assembly consisting of one or more locking device(s) and one or more operating device(s)

3.10**junction line**

intersection of the seat and the back rest

4 General**4.1 Test conditions**

The high chair shall be tested as delivered. If the high chair is a knock-down type, it shall be assembled according to the instructions supplied with it. If the instructions allow for different adjustments or configurations of components (e.g. inclination of the backrest, height of the seat, position of the tray, position of castors/wheels, etc.), the most onerous combination shall be used for each test, unless otherwise specified in the test method.

Knock-down fittings shall be tightened before testing. Further re-tightening shall not take place.

4.2 Application of forces

The forces in the static load tests shall be applied sufficiently slowly to ensure that negligible dynamic force is applied.

The tests are described in terms of the application of forces, however masses can be used. The relationship $10\text{ N} = 1\text{ kg}$ shall be used for this purpose.

4.3 Tolerances

Unless otherwise stated, the following tolerances apply:

- Forces: $\pm 5\%$ of the nominal force;
- Masses: $\pm 0,5\%$ of the nominal mass;
- Dimensions: $\pm 1,0\text{ mm}$ of the nominal dimension;
- Angles: $\pm 2^\circ$ of the nominal angle;
- Positioning of loading pads: $\pm 5\text{ mm}$.

NOTE For the purposes of uncertainty in measurements, test results are not considered to be adversely affected when the above tolerances are met.

4.4 Test sequence

The tests in Clause 8 shall be carried out on the same high chair and in the order of the clauses of this standard.

4.5 Determination of the junction line

The junction line is shown in Figure 1 below.

Where the backrest and the seat do not meet, the junction line is the projection of the backrest onto the seat (see Figure 1).

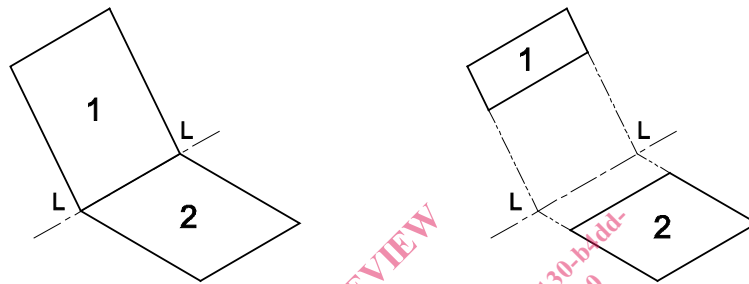

Key

- LL junction line
- 1 backrest
- 2 seat

Figure 1 — Junction line

When the seat unit is in the form of a hammock, a theoretical junction line, "LL", shall be determined as shown in Figure 2. The junction line may vary when the backrest is adjusted in different positions.

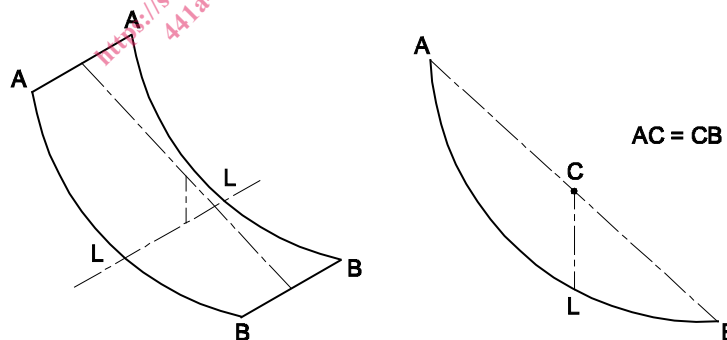

Key

- AA top edge of the backrest
- BB front edge of the seat
- LL junction line
- CL vertical projection of C on the hammock
- C mid-point between A and B

Figure 2 — Junction line for seat units in the form of a hammock

EN 14988:2017+A1:2020 (E)

5 Test equipment

5.1 General

Unless otherwise specified, test forces may be applied by any suitable device as results are dependent only upon correctly applied forces and not upon the apparatus.

5.2 Test mass A

A rigid cylinder 200 mm in diameter and 300 mm in height, having a mass of 15 kg with its centre of gravity 150 mm above its base. The edges shall have a radius of 5 mm. Two anchorage points shall be provided. These shall be positioned 150 mm from the base and at an angle of 180° to each other around the circumference (see Figure 3).

Dimensions in millimetres

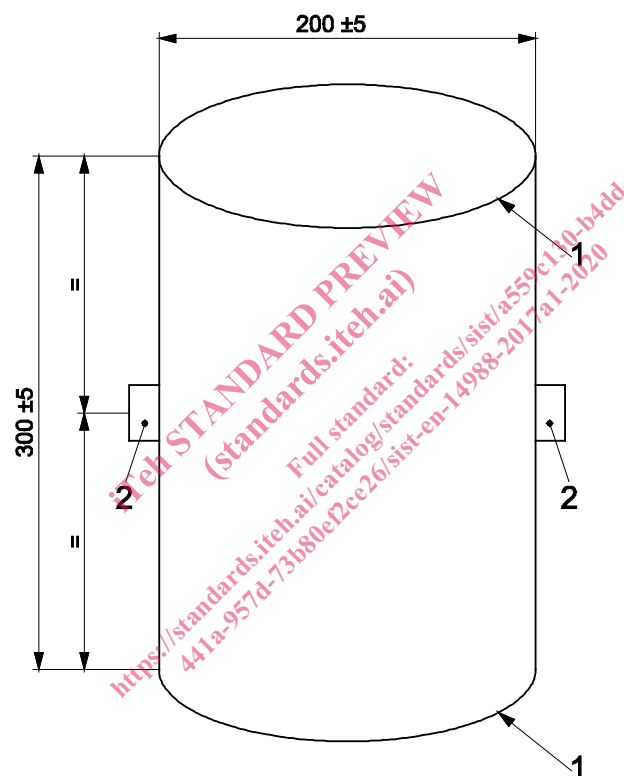

Key

- 1 edge radius: (5 ± 1) mm
- 2 anchorage points

Figure 3 — Test mass A

5.3 Impact hammer

A striker in the form of a cylindrical object having a total mass of 6,5 kg supported from a pivot by a steel tube of 38 mm in diameter and with a wall thickness of 2 mm (see Figure 4). The distance between the pivot and the centre of gravity of the striker shall be 1 000 mm. The pendulum arm shall be pivoted by a low friction bearing.

Dimensions in millimetres

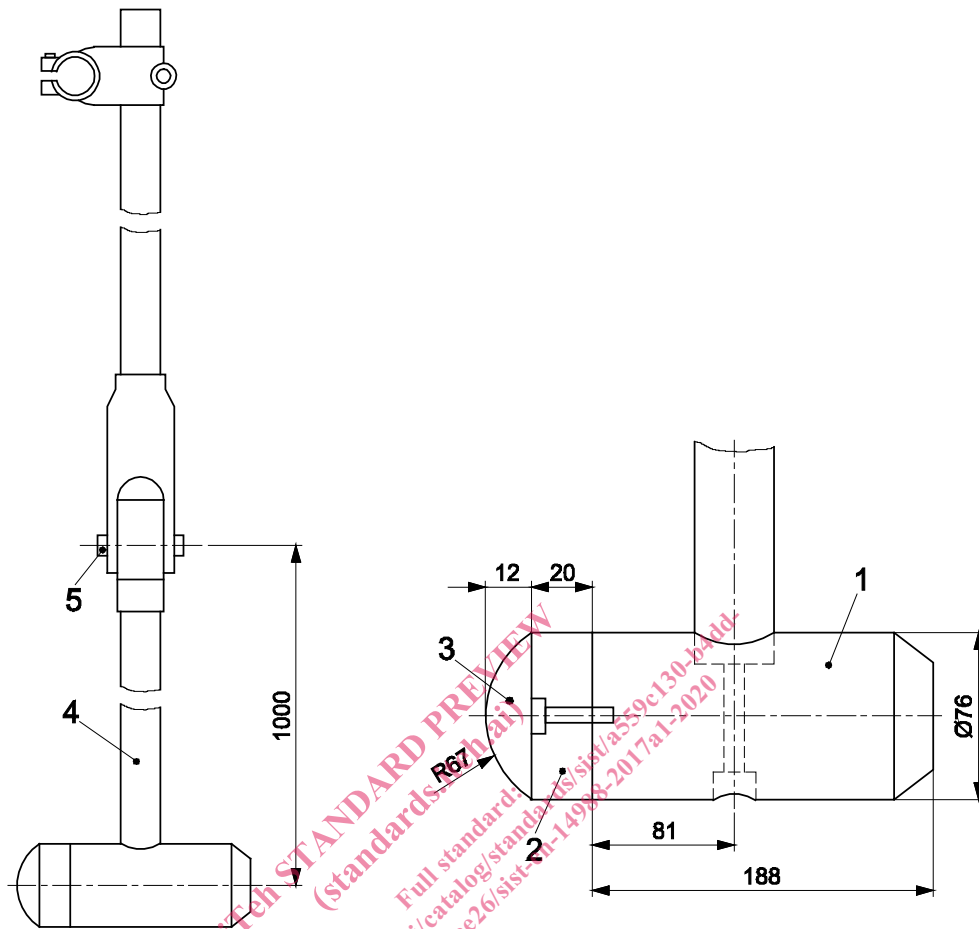
**Key**

- 1 pendulum head, steel mass 6,4 kg
- 2 hardwood
- 3 rubber 50 ± 10 Shore A (ISO 7619-1)
- 4 pendulum arm, length 950 mm; high tensile steel tube $\varnothing 38$ mm x 2 mm; mass $(2 \pm 0,2)$ kg
- 5 pivot point

Mass of assembly (Key numbers 1, 2 and 3): $(6,5 \pm 0,07)$ kg

Figure 4 — Impact hammer

5.4 Large loading pad

A rigid cylindrical object 100 mm in diameter having a smooth hard surface and edges rounded with radius of 12 mm.

5.5 Small loading pad

A rigid cylindrical object 30 mm in diameter having a smooth hard surface and edges rounded with radius of $(0,8 \pm 0,3)$ mm.

EN 14988:2017+A1:2020 (E)

5.6 Stops

Stops to prevent the high chair from sliding but not tilting, no higher than 12 mm except in cases where the design of the item necessitates the use of higher stops, in which case the lowest stops that will prevent the item from sliding shall be used.

5.7 Floor surface

A horizontal, flat and rigid plane with a smooth surface.

For the tests according to 8.8.6.4, a 2 mm thick rubber mat, with hardness (75 ± 10) Shore A according to ISO 7619-1, shall be used on a concrete floor.

5.8 Beams

5.8.1 Beam for stability testing and for measuring the length of the lateral protection

A beam, not less than 900 mm long, with a square section of 25 mm x 25 mm and with a mass of $(0,5 \pm 0,01)$ kg.

5.8.2 Beam for measuring the height for lateral protection test

A beam, 86 mm wide and with a mass of $(0,5 \pm 0,01)$ kg.

5.9 Probes for finger entrapment

Probes made of plastic or other hard, smooth material with diameters $(7_{-0,1}^0)$ mm and $(12_0^{+0,1})$ mm with a hemispherical end (see Figure 5) and which can be mounted on a force-measuring device.

Dimensions in millimetres

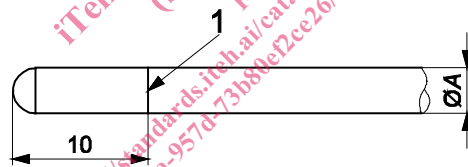

Key

1 line around the probe showing the depth of penetration

| Probe type | 7 mm probe | 12 mm probe |
|------------|--------------|---------------|
| Diameter A | $7_{-0,1}^0$ | $12_0^{+0,1}$ |

Figure 5 — Test probes with hemispherical ends

5.10 Test mass B

A cylinder with a mass of 5 kg and a diameter of 100 mm.

5.11 Small parts cylinder

A cylinder for assessment of small components, having dimensions in accordance with Figure 6.

Dimension in millimetres

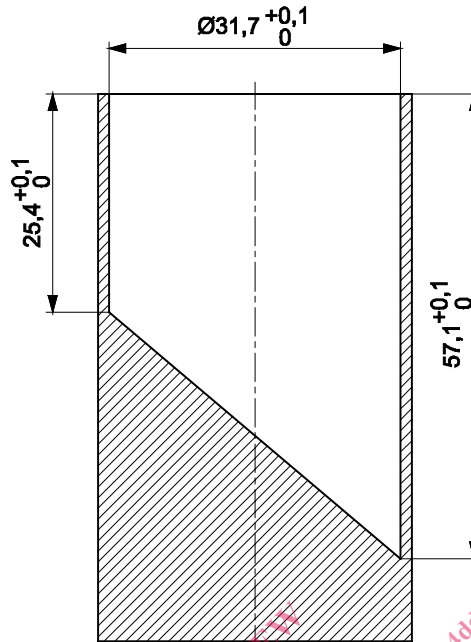
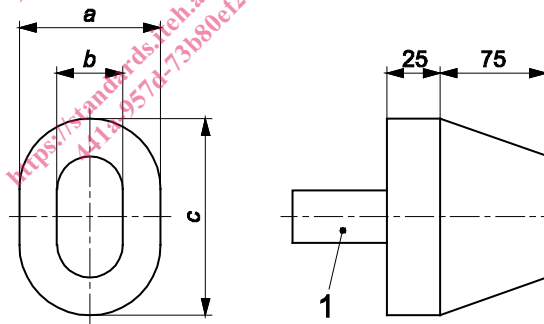

Figure 6— Small parts cylinder

5.12 Small torso probe

A probe made from plastic or other hard, smooth material with dimensions as shown in Figure 7.

Dimensions in millimetres



Key

- 1 handle
- a 86 mm
- b 40 mm
- c 120 mm

Figure 7 — Small torso probe

5.13 Test mass C

An object made of steel with a total mass of $(9 \pm 0,1)$ kg and with dimensions as specified in Figure 8.

All edges shall be rounded or chamfered.