Metallic coatings — Review of methods of measurement of ductility

*Revêtements métalliques — Vue d'ensemble sur les méthodes de
mesurage de la ductilité*

iTeh STANDARD PREVIEW
(standards.iteh.ai)

[ISO 8401:2017](https://standards.iteh.ai/catalog/standards/sist/ce2008c3-2a09-4eba-b4a2-c7431cef5518/iso-8401-2017)

[https://standards.iteh.ai/catalog/standards/sist/ce2008c3-2a09-4eba-b4a2-
c7431cef5518/iso-8401-2017](https://standards.iteh.ai/catalog/standards/sist/ce2008c3-2a09-4eba-b4a2-c7431cef5518/iso-8401-2017)



iTeh STANDARD PREVIEW
(standards.iteh.ai)

ISO 8401:2017

<https://standards.iteh.ai/catalog/standards/sist/ce2008c3-2a09-4eba-b4a2-c7431cef5518/iso-8401-2017>



COPYRIGHT PROTECTED DOCUMENT

© ISO 2017, Published in Switzerland

All rights reserved. Unless otherwise specified, no part of this publication may be reproduced or utilized otherwise in any form or by any means, electronic or mechanical, including photocopying, or posting on the internet or an intranet, without prior written permission. Permission can be requested from either ISO at the address below or ISO's member body in the country of the requester.

ISO copyright office
Ch. de Blandonnet 8 • CP 401
CH-1214 Vernier, Geneva, Switzerland
Tel. +41 22 749 01 11
Fax +41 22 749 09 47
copyright@iso.org
www.iso.org

Contents

	Page
Foreword	v
1 Scope	1
2 Normative references	1
3 Terms and definitions	1
4 Principle	2
5 Tests on unsupported foils	3
5.1 General.....	3
5.2 Tensile testing.....	4
5.2.1 Principle.....	4
5.2.2 Apparatus.....	4
5.2.3 Preparation of test pieces.....	4
5.2.4 Procedure.....	6
5.2.5 Expression of results.....	6
5.2.6 Notes on procedure.....	6
5.3 Bending (micrometer bend test).....	7
5.3.1 General.....	7
5.3.2 Apparatus.....	7
5.3.3 Preparation of test pieces.....	7
5.3.4 Procedure.....	7
5.3.5 Expression of results.....	8
5.4 Folding (vice-bend test).....	10
5.4.1 General.....	10
5.4.2 Apparatus.....	10
5.4.3 Preparation of test pieces.....	10
5.4.4 Procedure.....	10
5.4.5 Results.....	10
5.5 Hydraulic bulging.....	11
5.5.1 General.....	11
5.5.2 Principle.....	11
5.5.3 Apparatus.....	11
5.5.4 Procedure.....	12
5.5.5 Expression of results.....	13
5.5.6 Notes on procedure.....	13
5.6 Mechanical bulging.....	13
5.6.1 General.....	13
5.6.2 Apparatus.....	14
5.6.3 Procedure.....	14
5.6.4 Expression of results.....	15
5.6.5 Special cases.....	15
6 Tests on coatings on substrates	17
6.1 General.....	17
6.2 Tensile testing.....	18
6.2.1 Apparatus.....	18
6.2.2 Preparation of test pieces.....	18
6.2.3 Procedure.....	18
6.3 Three-point bending ^[10]	19
6.3.1 Principle.....	19
6.3.2 Apparatus.....	19
6.3.3 Procedure.....	19
6.3.4 Expression of results.....	20
6.4 Four-point bending ^[11]	21
6.4.1 General.....	21

6.4.2	Expression of results	21
6.5	Cylindrical mandrel bending	22
6.5.1	Principle	22
6.5.2	Apparatus	22
6.5.3	Preparation of test pieces	23
6.5.4	Procedure	23
6.5.5	Expression of results	23
6.5.6	Notes on procedure	23
6.6	Spiral mandrel bending	23
6.6.1	Principle	23
6.6.2	Apparatus	24
6.6.3	Procedure	24
6.6.4	Expression of results	24
6.7	Conical mandrel bending	25
6.7.1	Principle	25
6.7.2	Apparatus	25
6.7.3	Procedure	25
6.7.4	Expression of results	25
6.7.5	Special cases	26
6.8	Mechanical bulging	26
6.8.1	Apparatus	26
6.8.2	Preparation of test pieces	26
6.8.3	Procedure	26
6.8.4	Expression of results	26
7	Selection of test method	27
8	Test report	28
<p>STANDARD PREVIEW (standards.iteh.ai)</p>		
Annex A (informative) Methods of producing foils		29
Annex B (informative) Calculation of ductility when increasing the surface area of a foil (bulging)		31
Annex C (informative) Calculation of ductility and tensile strength in the hydraulic bulge test		34
Annex D (informative) Calculation of ductility in the mechanical bulge test		37
Bibliography		38

Foreword

ISO (the International Organization for Standardization) is a worldwide federation of national standards bodies (ISO member bodies). The work of preparing International Standards is normally carried out through ISO technical committees. Each member body interested in a subject for which a technical committee has been established has the right to be represented on that committee. International organizations, governmental and non-governmental, in liaison with ISO, also take part in the work. ISO collaborates closely with the International Electrotechnical Commission (IEC) on all matters of electrotechnical standardization.

The procedures used to develop this document and those intended for its further maintenance are described in the ISO/IEC Directives, Part 1. In particular the different approval criteria needed for the different types of ISO documents should be noted. This document was drafted in accordance with the editorial rules of the ISO/IEC Directives, Part 2 (see www.iso.org/directives).

Attention is drawn to the possibility that some of the elements of this document may be the subject of patent rights. ISO shall not be held responsible for identifying any or all such patent rights. Details of any patent rights identified during the development of the document will be in the Introduction and/or on the ISO list of patent declarations received (see www.iso.org/patents).

Any trade name used in this document is information given for the convenience of users and does not constitute an endorsement.

For an explanation on the meaning of ISO specific terms and expressions related to conformity assessment, as well as information about ISO's adherence to the World Trade Organization (WTO) principles in the Technical Barriers to Trade (TBT) see the following URL: www.iso.org/iso/foreword.html.

This document was prepared by Technical Committee ISO/TC 107, *Metallic and other inorganic coatings*.

This second edition cancels and replaces the first edition (ISO 8401:1986), of which it constitutes a minor revision. The following changes have been made:

- [Formula \(C.10\)](#) has been corrected;
- changes have been made in line with the 2016 edition of the ISO/IEC Directives, Part 2.

iTeh STANDARD PREVIEW
(standards.iteh.ai)

ISO 8401:2017

<https://standards.iteh.ai/catalog/standards/sist/ce2008c3-2a09-4eba-b4a2-c7431cef5518/iso-8401-2017>

Metallic coatings — Review of methods of measurement of ductility

1 Scope

This document specifies general methods for measuring the ductility of metallic coatings of thickness below 200 μm prepared by electroplating, autocatalytic deposition or other processes.

It is applicable to the following methods:

- tests on unsupported foils (separated from the substrate);
- tests of coatings on substrates.

It does not apply to International Standards that include specific methods of testing for individual coatings. In these cases, the methods specified are used in preference to the methods described in this document and are agreed upon beforehand by the supplier and the purchaser.

2 Normative references

There are no normative references in this document.

3 Terms and definitions

For the purposes of this document, the following terms and definitions apply.

ISO and IEC maintain terminological databases for use in standardization at the following addresses:

- IEC Electropedia: available at <http://www.electropedia.org/>
- ISO Online browsing platform: available at <http://www.iso.org/obp>

3.1

ductility

ability of a metallic or other coating to undergo plastic or elastic deformation, or both, without fracture or cracking

3.2

linear elongation

ratio of the elongation, Δl , to a definite initial length, l_0 , of the test piece

Note 1 to entry: This is taken as a measure of ductility.

Note 2 to entry: Often, this ratio is expressed as a percentage.

Note 3 to entry: Normally, the test pieces are elongated [see [Figure 1 a\)](#)]. With some bending tests, the outer layer of the test piece, i.e. the plating, is elongated. In bulge tests, however, the surface of the foil is enlarged, requiring calculation of linear elongation from the reduction in the thickness. Using the component of deformation (stretching) in only one axis would give false information about the ductility of the material [see [Figure 1 b\)](#)]. In those cases, the thinning of the foil, as calculated from the increase in the surface area, is a better measure of the ductility of the material (see [Annex B](#)).

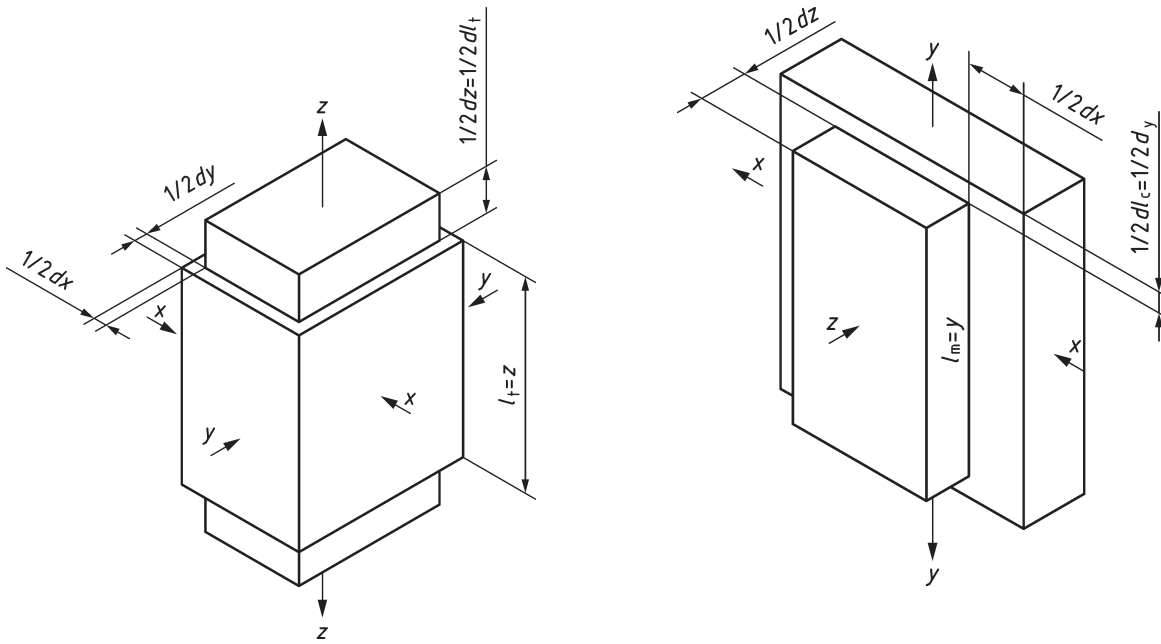

$$xyz = (x - dx)(y - dy)(z + dz)$$

$$xyz = xyz + xydz - xzdy - yzdx$$

$$\frac{dz}{z} = \frac{dy}{y} + \frac{dx}{x}$$

$$\frac{dz}{z} > \frac{dy}{y}$$

$$\frac{dl_t}{l_t} = \frac{dz}{z}$$

a) Tensile test

b) Cupping test

Figure 1 — Tensile and cupping tests

4 Principle

4.1 In the testing of unsupported foils separated from the substrate (see Figure 2), the foils may consist of one or more metallic layers. Therefore, it is possible to measure the ductility of composites and to determine the influence of individual layers on overall ductility. Methods of testing of unsupported foils are described in Clause 5. Methods of producing foils for testing are discussed in Annex A.

4.2 In the testing of coatings on substrates (see Figure 3), it is especially important to determine the exact point of crack initiation of the top layer. Attention is drawn to different methods of discerning this point, by normal or corrected-to-normal vision or with a lens. See the guidance in the individual methods.

These methods can also be used to detect embrittlement of the substrate that may have resulted from the coating process. Methods of testing of coatings on substrates are described in [Clause 6](#).

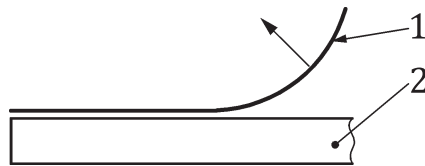

Key

- 1 metal foil
- 2 substrate

Figure 2 — Foil, which can be separated from the substrate

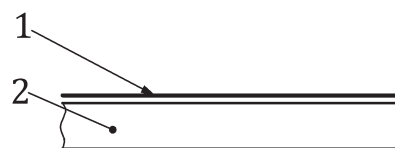

Key

- 1 coating
- 2 substrate

iTeh STANDARD PREVIEW
Figure 3 — Coating on the substrate
 (standards.iteh.ai)

4.3 Although ductility is a property of the material and independent of the dimensions of the test piece, thickness of the coating may have an influence on the value of linear elongation ($\Delta l/l_0$).

4.3.1 Very thin layers have different properties as the build-up of the initial layers will be influenced by the properties of the substrate (epitaxy). High internal stresses may be incorporated into the initial layers and these may affect ductility.

4.3.2 It is essential that the test piece has uniform thickness, as thinner spots will give rise to premature cracking. Also, the current density is lower at thinner parts and higher at thicker parts of electroplated test pieces; in this way, current density differences may result in different ductilities. The current density applied should be maintained as uniform as possible over the test piece, and its value reported.

5 Tests on unsupported foils

5.1 General

These techniques involve measurement of a foil which has been separated from the substrate (see [Figure 2](#)). In this case, the foil to be tested can also consist of several layers so as to allow measurement of the influence of undercoats on the ductility of the foil sandwich. Examples are gold flash on gold/copper alloys and chromium-plated nickel deposits. Methods of producing unsupported foils are given in [Annex A](#).

Five methods are described: tensile testing ([5.2](#)), bending (micrometer bend test) ([5.3](#)), folding (vice-bend test) ([5.4](#)), hydraulic bulging ([5.5](#)) and mechanical bulging ([5.6](#)).

5.2 Tensile testing

5.2.1 Principle

Determination of the linear elongation of a foil, which is clamped into the jaws of a tensile testing machine. In this type of stressing, the foil is lengthened, but both the width and the thickness of the foil diminish.

5.2.2 Apparatus

This method may utilize conventional mechanical testing equipment, available commercially and in many metallurgical laboratories^[1]. For some applications, tensile testing equipment adapted to microscopic inspection during the test may be used.

5.2.3 Preparation of test pieces

Test pieces may be machined, chipped, punched or cut from the metallic foil or prepared by photoprinting with the help of light-sensitive lacquers or light-sensitive foils which are pressed onto a suitable substrate. After developing the pattern of the test piece, it is plated into the final form. A similar method uses chemical or electrochemical milling of the desired shape from a foil on which has been applied a suitable resist by silk screen printing or by applying a photosensitive resist. These last methods are widely used in the printed circuit industry. The test pieces are usually rectangular in shape (see [Table 1](#) for recommended dimensions), but can be widened at both ends to avoid breaking in the clamping jaws (see [Figure 4](#)).

Table 1 — Possible dimensions of tensile test pieces^[1]

Gauge length	(mm)	200	50	25
Width	(mm)	40	12,5	6,25

Some methods of preparing the test pieces may cause microcracking at the edges that results in premature failure and erratic results. Test piece preparation involving photoprinting or electroforming is preferred to avoid edge defects.

Test pieces plated into the final form may have thicker edges unless shielding and other techniques are used to ensure uniform current distribution (see [Figure 5](#)).

Make equidistant marks on the surface of the test piece as illustrated in [Figure 4 a\)](#). Determine the distance between the marks before testing.

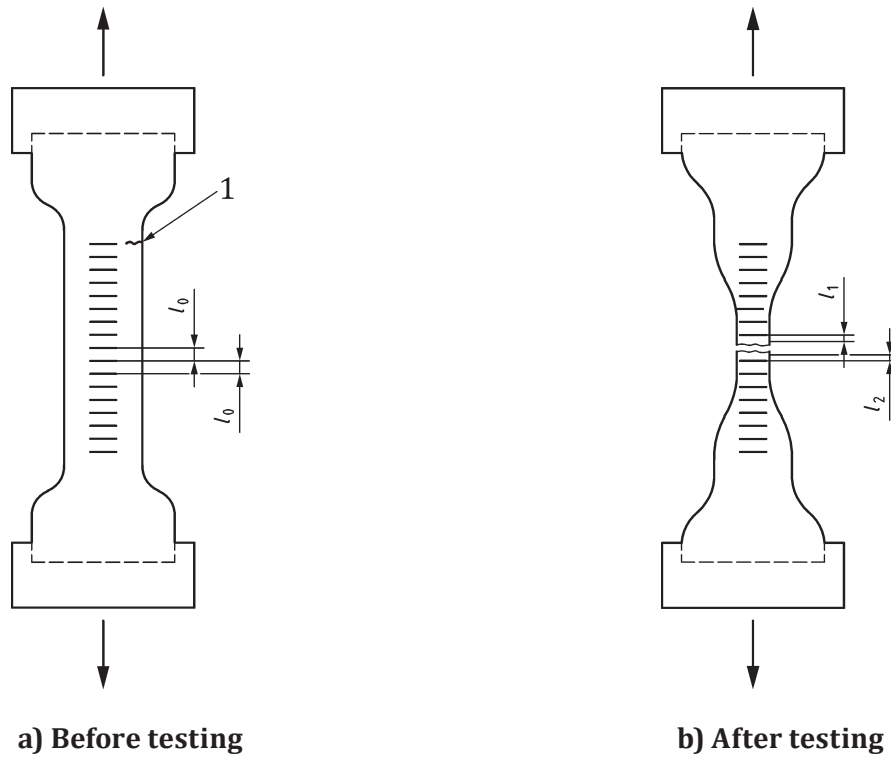

iTeh STANDARD PREVIEW
 (standards.iteh.ai)

$$l_0 + \Delta l = l_1 + l_2$$

$$\Delta l = \frac{l_1 + l_2 - l_0}{l_0}$$

<https://standards.iteh.ai/catalog/standards/sist/c0008c3-2a09-4eba-b4a2-c7431cef5518/iso-8401-2017>

Key

1 microcracks

Figure 4 — Tensile testing specimen before and after testing

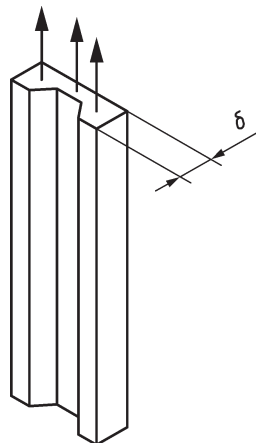

Figure 5 — Plated test pieces with thicker edges

5.2.4 Procedure

Clamp the test piece between the jaws of the tensile test equipment and apply strain using a selected cross-head speed. Determine the distance between the marks on the test pieces after testing [see [Figure 4 b](#)].

5.2.5 Expression of results

5.2.5.1 Calculation

The ductility, D , expressed as a percentage, is given by [Formula \(1\)](#):

$$D = \frac{l_1 + l_2 - l_0}{l_0} \times 100 \quad (1)$$

where

l_0 is the distance between the marks before testing;

$l_1 + l_2$ is the distance between the marks after testing.

5.2.5.2 Coefficient of variation

Mechanically prepared test pieces can have coefficients of variation, s/\bar{D} (where s is the standard deviation and \bar{D} the mean ductility), as high as 20%.

By plating into the final form using shields to ensure uniform current distribution, test pieces can be produced which have lower coefficients of variation.

5.2.6 Notes on procedure

5.2.6.1 Necking of the test piece [see [Figure 4 b](#)] may require measurement of very small changes in length and the use of a microscope that has a Vernier scale.

5.2.6.2 Mounting fragile thin test pieces into the jaws of a tensile testing machine may give rise to prestressed test pieces which thereby diminish the real value of elongation.

5.2.6.3 Care shall be taken to avoid twisting of the test piece (see [Figure 6](#)).

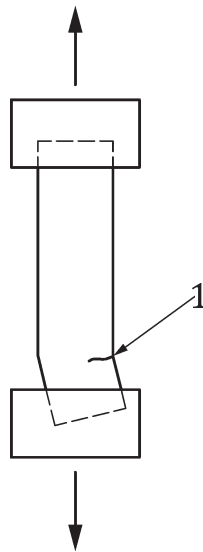

Key

1 microcracks

Figure 6 — Twisted test piece

iTeh STANDARD PREVIEW

5.2.6.4 When these sources of error (5.2.6.1 to 5.2.6.3) cannot be eliminated, other methods of measuring ductility should be used.

ISO 8401:2017

5.3 Bending (micrometer bend test)

5.3.1 General

This method is suitable only for the evaluation of metallic foils having low ductility^[2]. The values obtained have no simple relation to values obtained by other methods. This method is useful for brittle metals such as bright nickel.

5.3.2 Apparatus

5.3.2.1 Micrometer.

5.3.3 Preparation of test pieces

Cut strips of 0,5 cm × 7,5 cm from the foil under test. The foils are usually 25 μm to 40 μm thick. The difficulties described in [5.2.3](#) and [5.2.6](#) apply likewise to this test. Measure the thickness of the test piece at the point of bending, using an instrument or method which enables the thickness to be determined with maximum 5 % uncertainty.

5.3.4 Procedure

Bend the test piece into a U-shape and place it between the jaws of the micrometer ([5.3.2.1](#)) so that as the jaws are closed, the bend remains between the jaws. Close the micrometer jaws slowly until the foil cracks.

Record the micrometer reading and the thickness of the foil (see [Figure 7](#)).

Carry out the test at least in duplicate.