**Measurement of radioactivity in the
environment — Air: radon-222 —**

Part 12:

**Determination of the diffusion
coefficient in waterproof materials:
membrane one-side activity
concentration measurement method**

iTeh STANDARD PREVIEW
(standards.iteh.ai)

*Mesurage de la radioactivité dans l'environnement — Air : radon
222 — ISO/TS 11665-12:2018*

<https://standards.iteh.ai/catalog/standards/sist/1c97ba53-ad86-4c7f-91ef-5a7e3c4dd212/iso-ts-11665-12-2018>

*Partie 12: Détermination du coefficient de diffusion des matériaux
imperméables: méthode de mesure de l'activité volumique d'un côté
de la membrane*



iTeh STANDARD PREVIEW (standards.iteh.ai)

ISO/TS 11665-12:2018

<https://standards.iteh.ai/catalog/standards/sist/1c97ba53-ad86-4c7f-91e5-5a7e3c4dd212/iso-ts-11665-12-2018>



COPYRIGHT PROTECTED DOCUMENT

© ISO 2018

All rights reserved. Unless otherwise specified, or required in the context of its implementation, no part of this publication may be reproduced or utilized otherwise in any form or by any means, electronic or mechanical, including photocopying, or posting on the internet or an intranet, without prior written permission. Permission can be requested from either ISO at the address below or ISO's member body in the country of the requester.

ISO copyright office
CP 401 • Ch. de Blandonnet 8
CH-1214 Vernier, Geneva
Phone: +41 22 749 01 11
Fax: +41 22 749 09 47
Email: copyright@iso.org
Website: www.iso.org

Published in Switzerland

Contents

| | Page |
|---|-----------|
| Foreword | iv |
| Introduction | v |
| 1 Scope | 1 |
| 2 Normative references | 1 |
| 3 Terms, definitions and symbols | 1 |
| 3.1 Terms and definitions..... | 1 |
| 3.2 Symbols..... | 2 |
| 4 Principle | 3 |
| 5 Equipment | 5 |
| 6 Sample preparation | 6 |
| 6.1 General consideration..... | 6 |
| 6.2 Fixing the sample in the holder..... | 7 |
| 6.3 Connection of the holder (cap) with the chamber..... | 7 |
| 7 Control measurements | 8 |
| 7.1 Verification of radon-tightness..... | 8 |
| 7.2 Calibration..... | 9 |
| 7.3 Detector background..... | 9 |
| 7.4 Instrument statistical fluctuation..... | 9 |
| 8 Measurement of radon activity concentration | 10 |
| 9 Processing and expression of the results for the sample | 11 |
| 9.1 Determination of the radon diffusion coefficient in the sample..... | 11 |
| 9.2 Characteristics of measurement limits..... | 11 |
| 9.3 Estimation of confidence interval and uncertainty..... | 13 |
| 9.4 Expression of the results..... | 13 |
| 10 Requirements for the test | 14 |
| 11 Influencing factors | 15 |
| 12 Expression of the results and assessment of the standard uncertainty for the material | 16 |
| 13 Quality management and calibration of the test device | 17 |
| 14 Test report | 17 |
| 14.1 The test report for material..... | 17 |
| 14.2 The test report for each sample..... | 18 |
| 14.3 Archived material..... | 18 |
| Annex A (informative) Determination of the radon diffusion coefficient of the sample | 19 |
| Bibliography | 27 |

Foreword

ISO (the International Organization for Standardization) is a worldwide federation of national standards bodies (ISO member bodies). The work of preparing International Standards is normally carried out through ISO technical committees. Each member body interested in a subject for which a technical committee has been established has the right to be represented on that committee. International organizations, governmental and non-governmental, in liaison with ISO, also take part in the work. ISO collaborates closely with the International Electrotechnical Commission (IEC) on all matters of electrotechnical standardization.

The procedures used to develop this document and those intended for its further maintenance are described in the ISO/IEC Directives, Part 1. In particular, the different approval criteria needed for the different types of ISO documents should be noted. This document was drafted in accordance with the editorial rules of the ISO/IEC Directives, Part 2 (see www.iso.org/directives).

Attention is drawn to the possibility that some of the elements of this document may be the subject of patent rights. ISO shall not be held responsible for identifying any or all such patent rights. Details of any patent rights identified during the development of the document will be in the Introduction and/or on the ISO list of patent declarations received (see www.iso.org/patents).

Any trade name used in this document is information given for the convenience of users and does not constitute an endorsement.

For an explanation of the voluntary nature of standards, the meaning of ISO specific terms and expressions related to conformity assessment, as well as information about ISO's adherence to the World Trade Organization (WTO) principles in the Technical Barriers to Trade (TBT) see www.iso.org/iso/foreword.html.

This document was prepared by Technical Committee ISO/TC 85, *Nuclear energy, nuclear technologies, and radiological protection*, Subcommittee SC 2, *Radiological protection*.

A list of all parts in the ISO 11665 series can be found on the ISO website.

Any feedback or questions on this document should be directed to the user's national standards body. A complete listing of these bodies can be found at www.iso.org/members.html.

Introduction

Radon isotopes 222, 219 and 220 are radioactive gases produced by the disintegration of radium isotopes 226, 223 and 224, which are decay products of uranium-238, uranium-235 and thorium-232 respectively, and are all found in the earth's crust. Solid elements, also radioactive, followed by stable lead are produced by radon disintegration[4].

When disintegrating, radon emits alpha particles and generates solid decay products, which are also radioactive (polonium, bismuth, lead, etc.). The potential effects on human health of radon lie in its solid decay products rather than the gas itself. Whether or not they are attached to atmospheric aerosols, radon decay products can be inhaled and deposited in the bronchopulmonary tree to varying depths according to their size.

Radon is today considered to be the main source of human exposure to natural radiation. UNSCEAR[5] suggests that, at the worldwide level, radon accounts for around 52 % of global average exposure to natural radiation. The radiological impact of isotope 222 (48 %) is far more significant than isotope 220 (4 %), while isotope 219 is considered negligible. For this reason, references to radon in this document refer only to radon-222.

Radon activity concentration can vary from one to more orders of magnitude over time and space. Exposure to radon and its decay products varies tremendously from one area to another, as it depends on the amount of radon emitted by the soil, weather conditions, and on the degree of containment in the areas where individuals are exposed.

As radon tends to concentrate in enclosed spaces like houses, the main part of the population exposure is due to indoor radon. Soil gas is recognized as the most important source of residential radon through infiltration pathways. Other sources are described in other parts of ISO 11665 and ISO 13164 series for water[2].

Radon enters into buildings via a diffusion mechanism caused by the all-time existing difference between radon activity concentrations in the underlying soil and inside the building, and via a convection mechanism inconstantly generated by a difference in pressure between the air in the building and the air contained in the underlying soil. Indoor radon activity concentration depends on radon activity concentration in the underlying soil, the building structure, the equipment (chimney, ventilation systems, among others), the environmental parameters of the building (temperature, pressure, etc.) and the occupants' lifestyle.

To limit the risk to individuals, a national reference level of 100 Bq·m⁻³ is recommended by the World Health Organization[6]. Wherever this is not possible, this reference level should not exceed 300 Bq·m⁻³. This recommendation that was endorsed by the European community member states establishes national reference levels for indoor radon activity concentrations. The reference levels for the annual average activity concentration in air cannot be higher than 300 Bq·m⁻³[8].

To reduce the risk to the overall population, building codes which require radon prevention measures in buildings under construction and radon mitigating measures in existing buildings should be implemented. Radon measurements are needed because building codes alone cannot guarantee that radon concentrations are below the reference level.

When a building requires protection against radon from the soil, radon-proof insulation (based on membranes, coatings or paints) placed between the soil and the indoors may be used as a stand-alone radon prevention/remediation strategy or in combination with other techniques such as passive or active soil depressurization. Radon-proof insulation functions at the same time as the waterproof insulation.

The radon diffusion coefficient is a parameter that determines the barrier properties of waterproof materials against the diffusive transport of radon. Applicability of the radon diffusion coefficient for radon-proof insulation can be prescribed by national building standards and codes. Requirements for radon-proof insulation as regards the durability, mechanical and physical properties and the maximum

design of value of the radon diffusion coefficient can also be prescribed by national building standards and codes.

As no reference standards and no reference materials are currently available for these types of materials, and related values of the radon diffusion coefficient, the metrological requirement regarding the determination of the performance of the different methods described in ISO/TS 11665-13 and in this document, as required by ISO 17025^[3], cannot be directly met.

NOTE The origin of radon-222 and its short-lived decay products in the atmospheric environment and the measurement methods are described in ISO 11665-1.

iTeh STANDARD PREVIEW
(standards.iteh.ai)

[ISO/TS 11665-12:2018](https://standards.iteh.ai/catalog/standards/sist/1c97ba53-ad86-4c7f-91e5-5a7e3c4dd212/iso-ts-11665-12-2018)

<https://standards.iteh.ai/catalog/standards/sist/1c97ba53-ad86-4c7f-91e5-5a7e3c4dd212/iso-ts-11665-12-2018>

Measurement of radioactivity in the environment — Air: radon-222 —

Part 12:

Determination of the diffusion coefficient in waterproof materials: membrane one-side activity concentration measurement method

1 Scope

This document specifies the method intended for assessing the radon diffusion coefficient in waterproofing materials such as bitumen or polymeric membranes, coatings or paints, as well as assumptions and boundary conditions which will be met during the test.

The test method described in this document allows to estimate the radon diffusion coefficient in the range of 10^{-5} m²/s to 10^{-12} m²/s [8][9] with an associated uncertainty from 10 % to 40 %.

2 Normative references

The following documents are referred to in the text in such a way that some or all of their content constitutes requirements of this document. For dated references, only the edition cited applies. For undated references, the latest edition of the referenced document (including any amendments) applies.

ISO 11665-1, *Measurement of radioactivity in the environment — Air: radon-222 — Part 1: Origins of radon and its short-lived decay products and associated measurement methods*

ISO 80000-10, *Quantities and units — Part 10: Atomic and nuclear physics*

ISO/IEC Guide 98-3, *Uncertainty of measurement — Part 3: Guide to the expression of uncertainty in measurement (GUM:1995)*

3 Terms, definitions and symbols

3.1 Terms and definitions

For the purposes of this document, the terms and definitions given in ISO 11665-1, ISO 80000-10 and the following apply.

ISO and IEC maintain terminological databases for use in standardization at the following addresses:

- ISO Online browsing platform: available at <https://www.iso.org/obp>
- IEC Electropedia: available at <http://www.electropedia.org/>

3.1.1

material

material produced according to certain technical specifications which is the object of the test

3.1.2

sample

certain amount of *material* (3.1.1) chosen from the production batch for determination of the *radon diffusion coefficient* (3.1.3)

3.1.3 radon diffusion coefficient

D
<bulk> radon activity permeating due to molecular diffusion through unit area of a monolayer material of unit thickness per unit time at unit radon activity concentration gradient on the boundaries of this material (3.1.1)

[SOURCE: ISO/TS 11665-13:2017, 3.1.3, modified — “<bulk>” has been added as the domain of the definition.]

3.1.4 decisive measurements

measurement results used to calculate the radon diffusion coefficient (3.1.3)

3.1.5 decisive volume of the chamber

volume of the chamber used to calculate the radon diffusion coefficient (3.1.3)

3.1.6 decisive area of the sample

material (3.1.1) sample (3.1.2) area used to calculate the radon diffusion coefficient (3.1.3)

3.1.7 radon transfer coefficient

radon transport in thin boundary layer of air near the surface of the sample (3.1.2)

Note 1 to entry: The default value of the radon transfer coefficient is 0,001 m/s to 0,1 m/s.

[SOURCE: ISO/TS 11665-13:2017, 3.1.15, modified — Note 1 to entry has been removed. Note 2 to entry has become Note 1 to entry and has been slightly rephrased.]

STANDARD PREVIEW
(standards.iteh.ai)
ISO/TS 11665-12:2018
<https://standards.iteh.ai/catalog/standards/sist/1c97ba53-ad86-4c7f-91e5-5a7e3c4dd212/iso-ts-11665-12-2018>

3.2 Symbols

For the purposes of this document, the symbols given in ISO 11665-1 and the following apply.

| | |
|-------------------|--|
| D | Radon diffusion coefficient of the sample, in square metre per second |
| $D^<$ | Lower limit of the confidence interval of the radon diffusion coefficient of the sample, in square metre per second |
| $D^>$ | Upper limit of the confidence interval of the radon diffusion coefficient of the sample, in square metre per second |
| D_M | Radon diffusion coefficient of the material, in square metre per second |
| λ | Radon decay constant, in per second |
| λ_L | Radon leakage rate, in per second |
| $\hat{\lambda}_L$ | Best estimate of the radon leakage rate, in per second |
| C | Radon activity concentration in the sample, in becquerel per cubic metre |
| C_{sd} | Radon activity concentration in a source-detect chamber, in becquerel per cubic metre |
| C_0 | Radon activity concentration in a source-detect chamber at the initial time after injection of radon, in becquerel per cubic metre |
| C_{amb} | Radon activity concentration in the ambient air, in becquerel per cubic metre |

| | |
|--------------|---|
| C_m | Measured radon activity concentration in a source-detect chamber, in becquerel per cubic metre |
| d | Thickness of the sample, in metre |
| S_s | Decisive area of the sample, in square metre |
| V_{sd} | Decisive volume of the source-detect chamber, in cubic metre |
| h | Radon transfer coefficient, in metre per second |
| t | Time, in second |
| τ_i | Time of start of i measurement period, in second (or hour) |
| r_g | Gross count rate, in counts per second |
| r_g^α | Gross count rate from alpha-source, in counts per second |
| r_0 | Background count rate, in counts per second |
| R_m | Measured rate of decrease of radon activity concentration in the chamber (of pulse count rate) |
| R_c | Calculated rate of decrease of radon activity concentration in the chamber |
| R_L | Calculated rate of decrease of radon activity concentration in the chamber at verification of radon-tightness |
| R_{min} | Function of the minimum measured rate of decrease in the chamber |
| R_{max} | Function of the maximum measured rate of decrease in the chamber |
| $u(y)$ | Standard uncertainty of the value of y |
| $s(y)$ | Standard deviation of the value of y |
| $u_{rel}(D)$ | Relative uncertainty of the radon diffusion coefficient in the sample |
| k | Coverage factor |
| N | Number of samples of the test material |

4 Principle

The one-side method is based on the measurement of the decrease over time of the radon activity concentration in a source-detect chamber in contact with one side of the tested membrane. The test is performed in a non-stationary mode. This test method can be used for single-layer waterproof materials when testing results are needed rapidly. They are not applicable for multi-layer waterproof materials that do not meet the requirements of [Figure 7](#).

A sample of the tested material is installed in the sealed end of the cylindrical chamber ([Figure 1](#)). The detector of radon activity is located at the other end of the chamber.

In the beginning of the test, a highly active portion of radon is injected into the chamber through a special valve. Since then, radon activity concentration in the chamber begins to decline because of

- a) diffusion of radon through the sample towards the ambient air,
- b) radon decay, and
- c) leakage of radon from the chamber.

The chamber serves as a source radon and also allows to measure radon activity in the chamber.

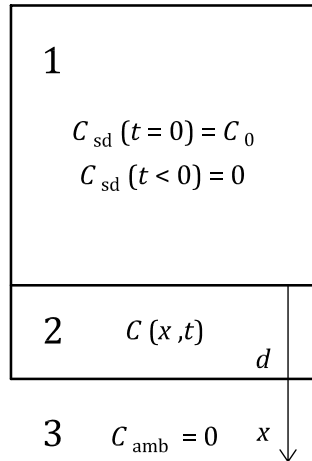

- Key**
- 1 source-detect chamber
 - 2 tested sample
 - 3 ambient air

Figure 1 — Measurement scheme

iTeh STANDARD PREVIEW
(standards.iteh.ai)

The process of radon transfer from the chamber through the sample is described by [Formulae \(1\)](#) and [\(2\)](#):

$$\frac{\partial C_{sd}(t)}{\partial t} = -\lambda \cdot C_{sd}(t) - \frac{S_s}{V_{sd}} \cdot h_1 \cdot [C_{sd}(t) - C(0,t)] \tag{1}$$

$$\frac{\partial C(x,t)}{\partial t} = D \frac{\partial^2 C(x,t)}{\partial x^2} - \lambda \cdot C(x,t), \quad 0 \leq x \leq d, \quad 0 \leq t < \infty \tag{2}$$

with the following boundary conditions in [Formulae \(3\)](#) to [\(5\)](#):

$$C_{sd}(t = 0) = C_0, \quad C(x, 0) = 0 \tag{3}$$

$$-D \frac{\partial C(0,t)}{\partial x} = h_1 \cdot [C_{sd}(t) - C(0,t)] \tag{4}$$

$$-D \frac{\partial C(d,t)}{\partial x} = h_2 \cdot [C(d,t) - C_{amb}], \quad [C_{amb}(t) = 0] \tag{5}$$

Formulae (1) to (5) with respect to the values of radon activity concentration in the chamber are solved as the function expressed by [Formula \(6\)](#):

$$C_{sd}(t) = C_0 \cdot f(t, D, \lambda, V_{sd}, S_s, d) \tag{6}$$

which is calculated as in [Formula \(7\)](#):

$$C_{sd}(t) = C_0 \left[\int_0^t e^{-\lambda(\tau-t)} F(\tau) d\tau + e^{-\lambda \cdot t} \right] \tag{7}$$

The calculation by [Formula \(7\)](#) is carried out by the algorithm described in [Annex A](#).

During the test, the ratios between current radon activity concentrations in the chamber to radon activity concentration at the beginning of the decisive measurements are registered. These ratios determine the rate of radon activity concentration decrease in the chamber (Clause 8).

The radon diffusion coefficient in the sample is calculated according to 9.1, taking into account the effect of radon leakage from the chamber.

5 Equipment

The scheme of the test installation is shown in Figure 2.

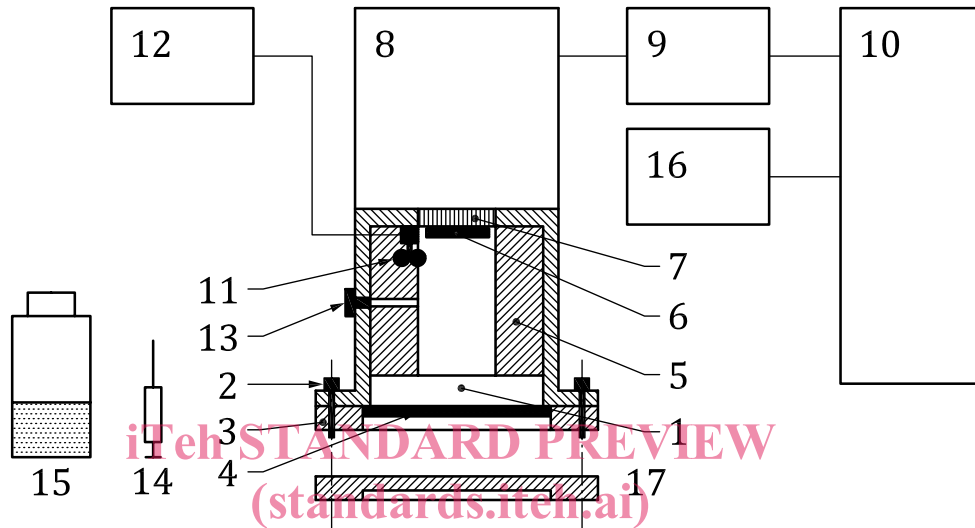

Key

| | |
|-----------------------------|----------------------------------|
| 1 chamber | 10 computer |
| 2 bolt (with washer) | 11 micro-fan |
| 3 holder | 12 power supply of the micro-fan |
| 4 sample | 13 valve |
| 5 insert | 14 syringe |
| 6 scintillation plate | 15 radon source |
| 7 light-transmissive window | 16 thermometer |
| 8 photomultiplier unit | 17 cap |
| 9 signal converter | |

Figure 2 — The scheme of the test installation

The installation includes an aluminium cylindrical chamber (1). The lower end of the chamber is a flange with a sealing gasket which is hermetically connected to the aluminium holders (3) with a test sample (4) by bolts (2).

Aluminium cylindrical inserts (5) are used to reduce the decisive volume of the chamber.

Scintillation plate (6) with sensitive ZnS(Ag) layer and light-transmissive window (7) made of polymethyl methacrylate are hermetically embedded in the upper end of the chamber.

The alpha radiation of radon and its progeny, interacting with the sensitive layer of the scintillator plate, causes light flashes (scintillations) which are converted into electrical pulses by the photomultiplier unit (8). These pulses are converted by the device (9) and transmitted to the computer (10). The computer software registers the average count rate at predetermined time intervals.

The micro-fan (11) provides stability in registering radon activity inside the chamber^[8]. The micro-fan is equipped with a brushless motor and a consumption current of less than 20 mA at a voltage not exceeding 5 V. The power of the micro-fan is provided by a power supply of stable voltage (12).

The sealed valve (13) for injecting radon inside the chamber with the syringe (14) is located on the sidewall of the chamber. The radon portion in the syringe is introduced from the radon source (15). The activity and the volume of the radon source should be 10 kBq to 100 kBq and 0,2 l to 0,5 l, respectively.

The thermometer (16) is connected to the computer.

The test installation is equipped with at least 3 holders and one aluminium cap (17).

To register the activity concentration, a semiconductor or another type of detector, located inside the chamber and meeting the requirements of [Clauses 7](#) and [10](#), can be also used.

The installation kit also includes

- a) a torque wrench with predetermined torque between 1 Nm and 10 Nm,
- b) a measuring instrument capable of determining the thickness of the tested sample with accuracy of $\pm 0,01$ mm (maximum standard relative measurement uncertainty of 5 %),
- c) an epoxy adhesive,
- d) alcohol, acetone, or another degreasing agent.

The chamber is set upright and the flange downwards ([Figure 2](#)) to avoid problems for radon exhalation from the sample.

Light shall not enter the chamber when the photomultiplier is on.

6 Sample preparation

<https://standards.iteh.ai/catalog/standards/sist/1c97ba53-ad86-4c7f-91e5-5a7e3c4dd212/iso-ts-11665-12-2018>
ISO/TS 11665-12:2018
(standards.iteh.ai)

6.1 General consideration

If the condition of [Formula \(29\)](#) is not satisfied after testing 3 samples, additional samples of the material should be prepared and tested until this condition is fulfilled.

The samples are cut out from the prefabricated membranes at a minimum distance of 20 mm from the edges of the membrane.

In the case of coatings, paints, sealants or other waterproof materials prepared on site, at least 3 samples are required for testing. Samples can be produced by applying a coating, paint or sealant on a non-absorbing flexible underlay material (for example wax-paper, cellophane, foil, etc.) that is removed from the sample after the drying process is completed. The underlay shall not react with the applied coatings, paints or sealants. Approximately uniform thickness of the samples can be achieved with the help of guide gibs (paint, coating or sealant is poured or pasted between the gibs of uniform height and the excessive material is removed by drawing the steel float over the gibs). The samples shall not be tested until the drying and hardening processes are completed. The time between the sample preparation and the start of the measurement as well as the storing conditions shall correspond to the recommendation of the producer.

The thickness of each sample is measured at 4 points per 0,01 m² placed uniformly along the surface of the sample. The resulting thickness of each sample is the arithmetic mean of all measurements on the sample. If a radon-permeable surface coating is part of the tested material, its thickness is not included in the thickness of the tested sample. This type of surface coating can be removed from the sample before performing the test.